

FEATURES

- *Stainless steel interior and exterior with galvanised back panel*
- *Heavy duty Embraco compressor*
- *Dixell digital temperature control system*
- *Self-closing and stay open doors*
- *Efficient refrigeration system*
- *Round corner design*
- *Recessed door handle*
- *Standard safety door lock*
- *Magnetic door gaskets*
- *Pre-installed castors*
- *Pre-installed mid-shelves*
- *Auto-defrost function*
- *Fan-forced cooling*
- *Allow 100 mm clearance for air ventilation*



Stainless steel GN pans included

MPF8201



MPF8202



MPF8203



INFORMATION	MPF8201	MPF8202	MPF8203
Capacity	396L	566L	880L
Power	300W	410W	600W
Voltage	220~240V/50Hz	220~240V/50Hz	220~240V/50Hz
Working Temp	+1°C~+8°C	+1°C~+8°C	+1°C~+8°C
Ambient Temp	43°C	43°C	43°C
Dimensions(mm)	W1117 x D840 x H1035,108kg	W1702 x D840 x H1035,152kg	W2362 x D840 x H1035,194kg
Packaging Dimensions(mm)	W1171 x D909 x H1167,134kg	W1755 x D909 x H1167,184kg	W2416 x D909 x H1167,239kg



2 YEARS WARRANTY ON ALL PARTS & LABOUR
 * EXTRA 2 YEARS WARRANTY ON PARTS WHEN YOU REGISTER WITH US ONLINE

PIZZA PREP TABLE REFRIGERATORS

view

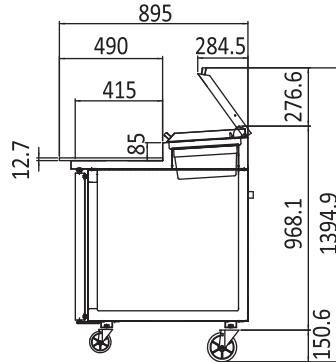

MPF8201

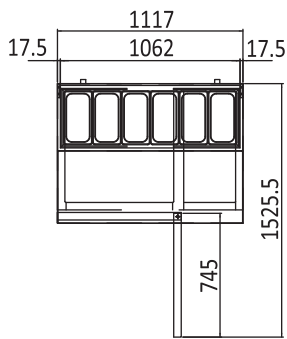

MPF8202

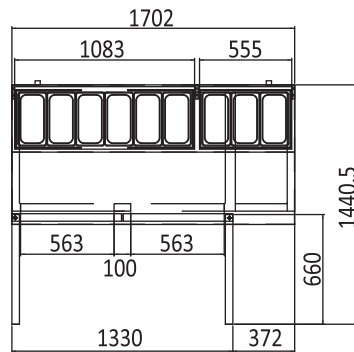

MPF8203

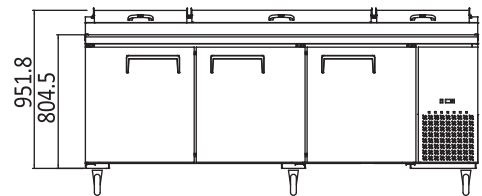
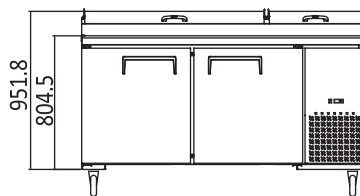
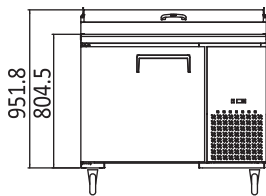
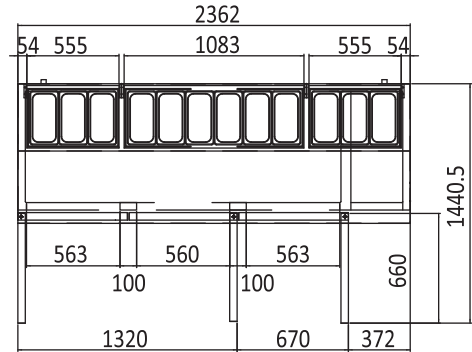

2 YEARS WARRANTY ON ALL PARTS & LABOUR
* EXTRA 2 YEARS WARRANTY ON PARTS WHEN YOU REGISTER WITH US ONLINE