

FEATURES

- *Hot food display*
- *Square glass*
- *Digital thermostat*
- *Flexible Italian brand silicon heater*
- *Sliding door*
- *Stylish heat lamps*
- *No exposed elements*



INFORMATION	CRB-4	CRB-6	CRB-8	CRB-10	CRB-12
Q'ty of included 1/2 pans	4	6	8	10	12
Power	2300W	2300W	2300W	3450W	3450W
Voltage	220V~240V	220V~240V	220V~240V	220V~240V	220V~240V
Adjustable temperature	+35°C~+85°C	+35°C~+85°C	+35°C~+85°C	+35°C~+85°C	+35°C~+85°C
Dimensions(mm)	W730x D650 x H780,43kg	W1055x D650 x H780,58kg	W1380 x D650 x H780,75kg	W1705x D650 x H780,92kg	W2030x D650 x H780,110kg
Packaging Dimensions(mm)	W780 x D710 x H850,56kg	W1110 x D710 x H850,73kg	W1430 x D710 x H850,93kg	W1760 x D710 x H850,115kg	W2080 x D710 x H850,142kg



2 YEARS WARRANTY ON ALL PARTS & LABOUR
 * EXTRA 2 YEARS WARRANTY ON PARTS WHEN YOU REGISTER WITH US ONLINE

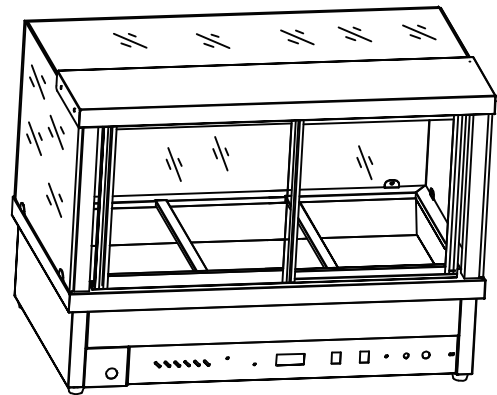
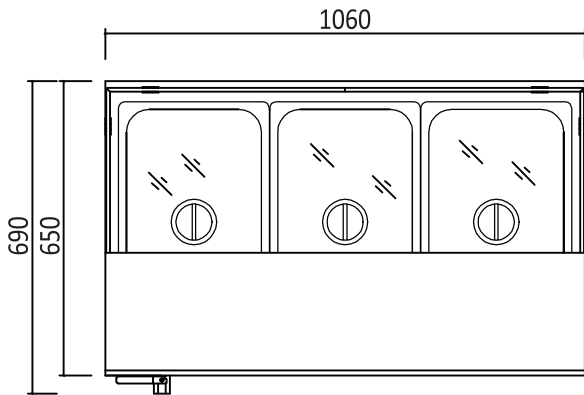
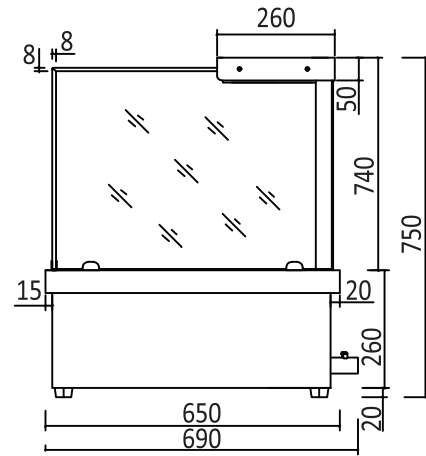
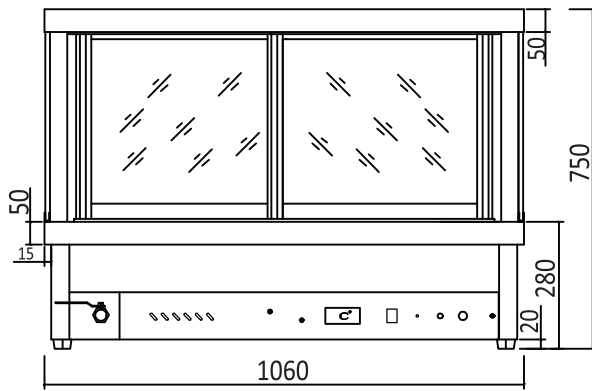

2 YEARS WARRANTY ON ALL PARTS & LABOUR
 * EXTRA 2 YEARS WARRANTY ON PARTS WHEN YOU REGISTER WITH US ONLINE