

FEATURES

- Performs well in hot environments
- High grade stainless steel interior & exterior
- Sliding lid cover on the ESL 3850
- Heavy duty stainless steel top prep area
- All fitted with European parts Compressor & EBM fan motor
- Aspera compressor
- 43-degree ambient working temperature
- Gas 134A refrigerant
- Insulation foam CH10, ODP zero emissions
- **STATIC COOLING SYSTEM**
- Carel / Dixell Italian digital controls
- Self-evaporating drainage
- Manual defrosting system
- We recommend you defrost regularly for better maintenance of temperatures
- Compressor & condenser situated on the bottom, so motor can breathe
- Unit can be positioned against a wall
- Fits Australian GN pans
- 3 Self-closing doors
- White Epoxy shelves & stainless-steel rails
- Comes installed with 4 castors for easy mobility
- ESL 3850 can fit GN Pans
- G/N pans & Lids are not included



ESL3850



ESL3851



INFORMATION	ESL3850	ESL3851
Capacity	380L	380L
Power	300W	300W
Voltage	220~240V/50Hz	220~240V/50Hz
Working Temp	-2°C~+8°C	-2°C~+8°C
Ambient Temp	43°C	43°C
Dimensions(mm)	W1365 x D700 x H888,90kg	W1365 x D700 x H880,90kg
Packaging Dimensions(mm)	W1419 x D754 x H1022,105kg	W1419 x D754 x H1022,105kg



2 YEARS WARRANTY ON ALL PARTS & LABOUR
 * EXTRA 2 YEARS WARRANTY ON PARTS WHEN YOU REGISTER WITH US ONLINE

ESL3850

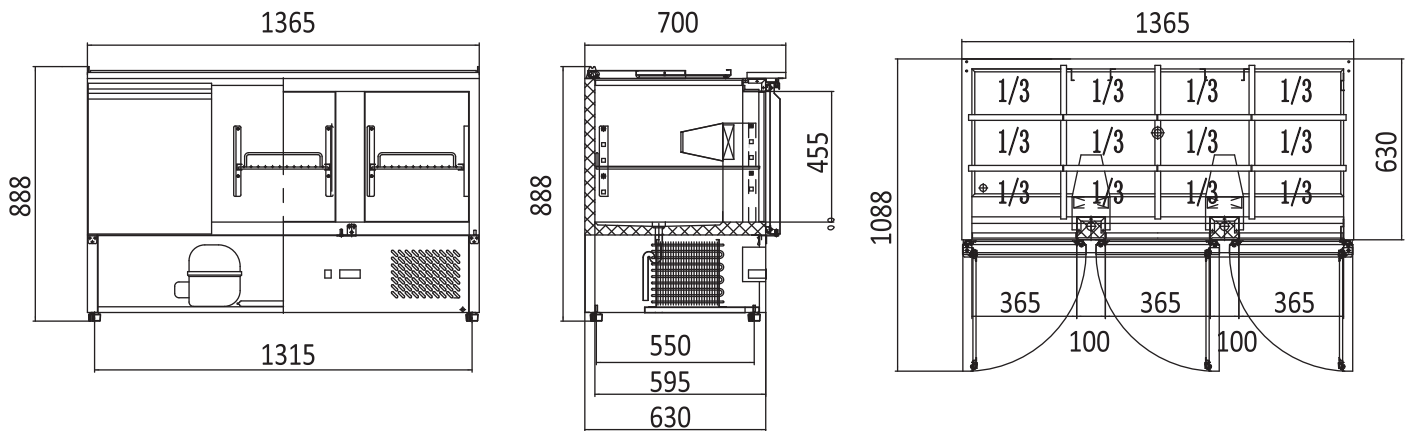

ESL3851

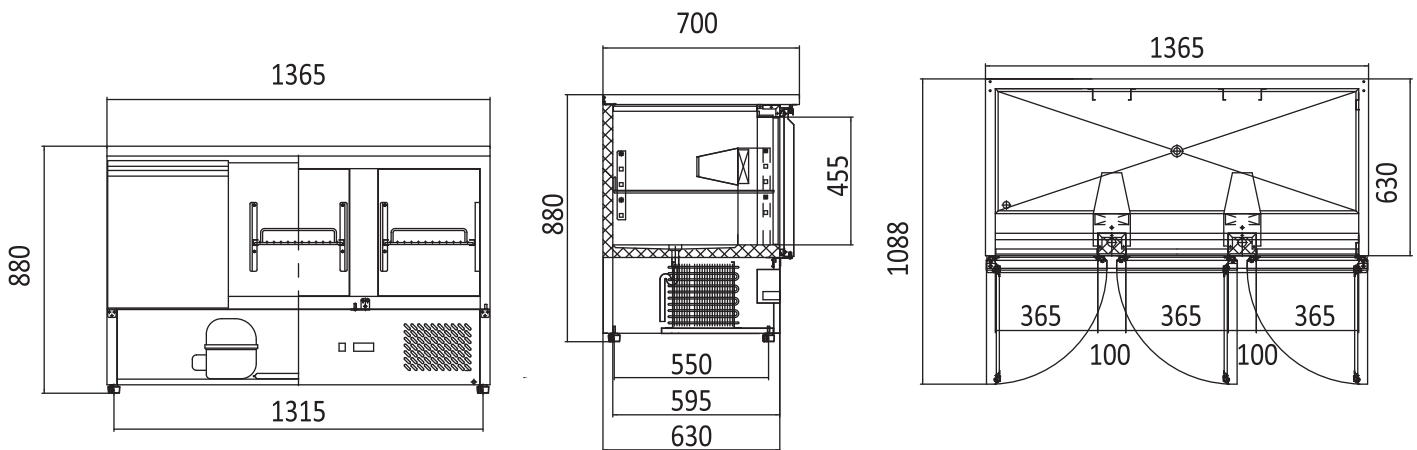

2 YEARS WARRANTY ON ALL PARTS & LABOUR
 * EXTRA 2 YEARS WARRANTY ON PARTS WHEN YOU REGISTER WITH US ONLINE