

FEATURES

- Constructed in 304 stainless steel
- Available in 3 sizes
- Gas Approved Australia wide
- Heavy duty constructed frame
- Stainless steel splash back
- Nickel plated frying baskets
- Standard flame failure
- Quick recovery
- Automatic safety valve stabilizing function
- Heavy duty tube burners with stable flame & standby pilots
- Easy to use low & high temp controls
- Fitted with American Robert Shaw valves & controls
- Heavy duty Robert Shaw USA thermostat
- Thermostatic temp control from 0 ~ 240 degrees
- Manual ignition
- Front screw on drain pipe for oil
- Oil cooling zone seated at bottom of the tank to avoid food residue
- Adjustable stainless-steel legs
- 3/4 inch gas inlet
- Available in NG & LPG
- 2 +2 Years parts & labour warranty

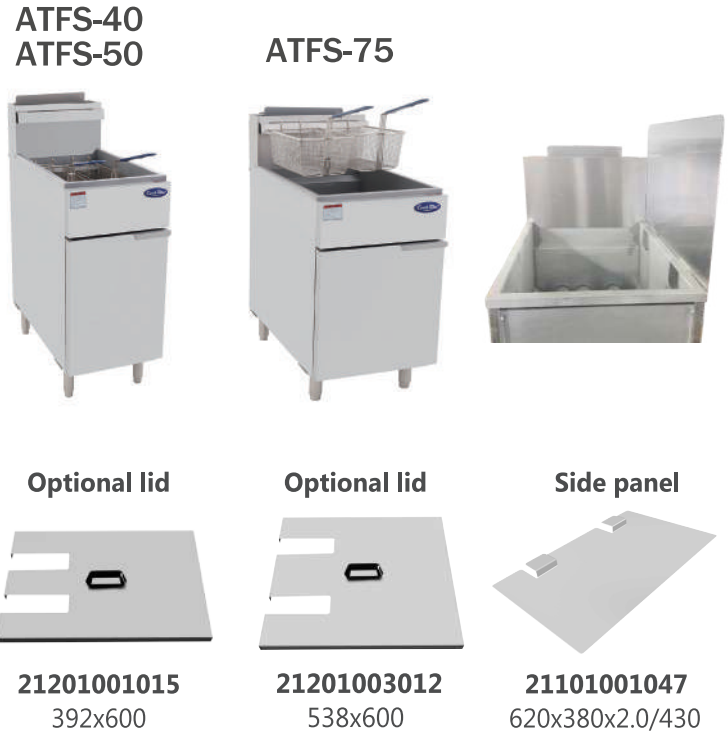

INFORMATION	ATFS-40	ATFS-50	ATFS-75
Oil Capacity	26.4L	26.6L	34.7L
Gas Type	NG/LPG	NG/LPG	NG/LPG
Gas Output per Burner Mj/h	28	28	28
Total power Output Mj/h(For even frying)	84	112	140
Dimensions(mm)	W395 x D765 x H1128, 59.5kg	W395 x D765 x H1128, 65.5kg	W535 x D765 x H1128, 76.5kg
Packaging Dimensions(mm)	W450 x D850 x H965, 72.5kg	W450 x D850 x H965, 78kg	W590 x D850 x H965, 90.5kg



AUSTRALIA AND NEW ZEALAND
GAS SAFETY CERTIFICATION
SAI-400249 AS 4563:2004 SAI Global



2 YEARS WARRANTY ON ALL PARTS & LABOUR
* EXTRA 2 YEARS WARRANTY ON PARTS WHEN YOU REGISTER WITH US ONLINE

DEEP FRYERS

ATFS-40/ATFS-50

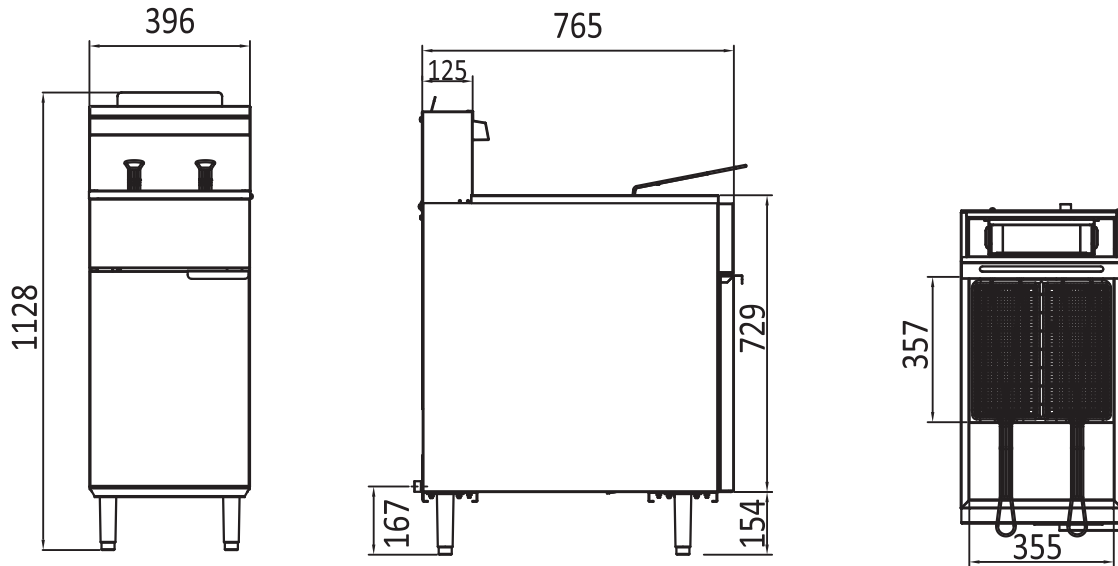

ATFS-75

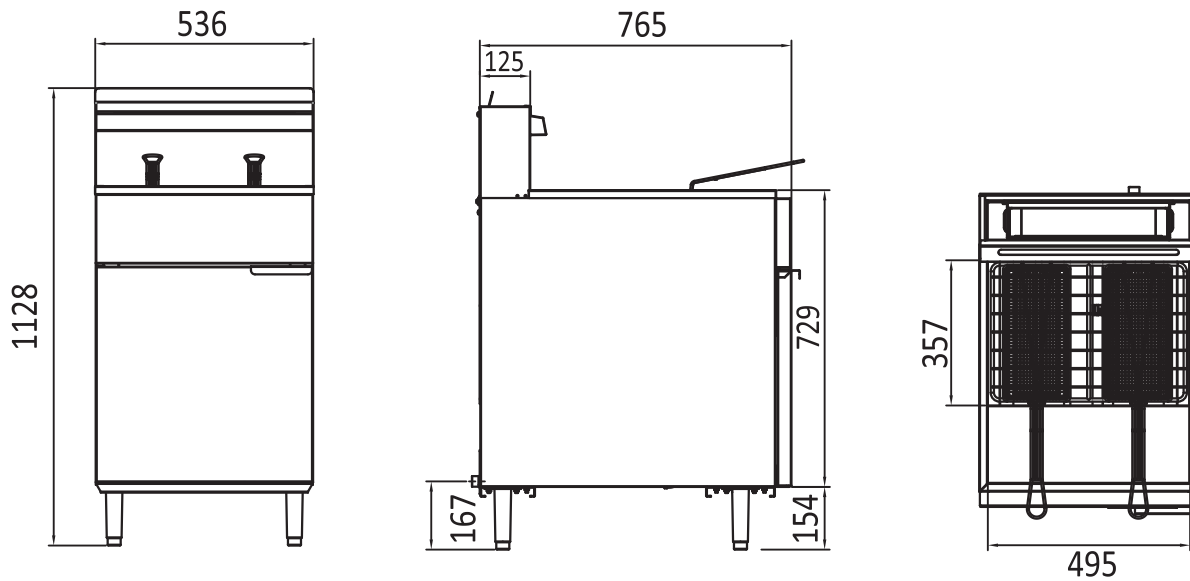

AUSTRALIA AND NEW ZEALAND
GAS SAFETY CERTIFICATION
SAI-400249 AS 4563:2004 SAI Global



2 YEARS WARRANTY ON ALL PARTS & LABOUR
* EXTRA 2 YEARS WARRANTY ON PARTS WHEN YOU
REGISTER WITH US ONLINE