

VERTICAL BUN TOASTER SINGLE SLOT

MANUFACTURING
SINCE 1966



Model: VTA0101



FEATURES

- Heavy duty stainless steel conveyor belt system
- Low noise operation
- Variable heat control 50° -300°C
- Slim design – small footprint
- Adjustable for various bun thicknesses
- 2.2kW element and an aluminium energy efficient heating plate for good heat distribution
- Single feed design
- Low energy consumption
- Precision cartridge bearing shafts
- Fast throughput - 22 buns per minute

NOTE:

- 1 x Teflon Release sheet that fits over plate element included



ALL ANVIL EQUIPMENT COMES WITH A TWO YEAR WARRANTY ON COMPONENTS AND DEFECTIVE WORKMANSHIP.

www.anvilworld.com



Model: VTA0101

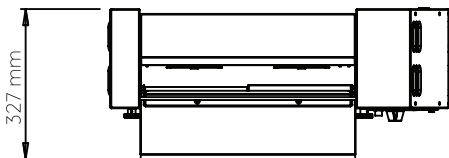
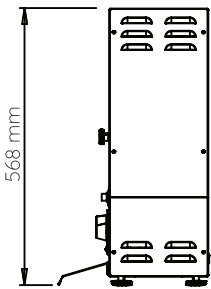
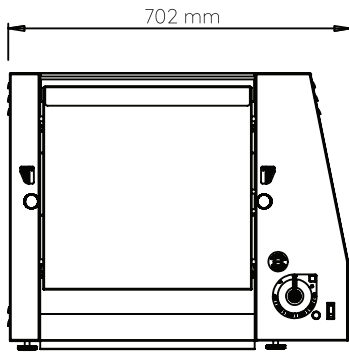

SPECIFICATIONS

POWER	2.2kW
VOLTAGE	230V - 50Hz
PACKAGING (W x D x H)	770 x 310 x 640 (mm)
UNIT (W x D x H)	702 x 327 x 568 (mm)
NET WEIGHT	27.6kg
GROSS WEIGHT	29.1kg
SHIPPING VOLUME	0.15m ³

AVAILABLE IN

120V/60Hz

OPTIONAL EXTRAS

TEFLON SHEET

CODE	DESCRIPTION
3-VTA0101-COFLON	Teflon sheet

NOTE

- When viewing the appliance from the front in its usual operating position, the width (W) of the product is the total distance from left to right; the depth (D) of the product is the total distance from the front to the back; the height (H) is the total distance from the bottom of the product to the top. Pictures may vary from actual product.

DISCLAIMER

- Output performance figures quoted are dependant on various factors. Anvil reserves the right, without notice, to make changes and revisions to product specifications, materials and design, when we believe it will provide better performance, durability, and efficiency. Unit measurements may vary depending on point of reference.



ALL ANVIL EQUIPMENT COMES WITH A TWO YEAR WARRANTY ON COMPONENTS AND DEFECTIVE WORKMANSHIP.

www.anvilworld.com