

# Operating Manual

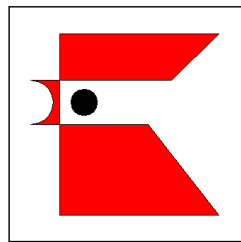

Quick Serve  
QS-Series



**ubert**<sup>®</sup>



# 1 Contents

1	Contents .....	3
2	Important references.....	4
2.1	Fundamental Safety Notes.....	4
2.2	Warranty and Liabilities.....	5
2.3	Symbols and Notes .....	5
2.4	Copyright.....	5
2.5	Special safety references.....	6
3	Introduction.....	8
3.1	Introduction .....	8
3.2	Special features .....	8
3.3	Technical details .....	9
4	Installation and putting into operation .....	11
4.1	Unwrapping .....	11
4.2	Installation .....	11
4.3	Electrical connection .....	11
4.4	Preparation of Using / Starting up .....	11
5	Operation.....	13
5.1	Operator panel .....	13
5.2	Adjustment of the shelves .....	14
6	Maintenance .....	15
6.1	Cleaning and care .....	15
6.2	Trouble shooting .....	17
6.3	Wiring Diagrams.....	18
6.4	Spare Parts .....	19
6.5	Declaration of Conformity.....	22

## 2 Important references

### 2.1 Fundamental Safety Notes

#### 2.1.1 Consider notes in the operating manual

- Precondition for the safe and trouble free use of this unit is the knowledge of the fundamental safety notes and safety regulations.
- The operating instruction contains the most important references to operate the unit safely.
- These operating instructions, particularly the safety references, are to be considered by all persons, who work on the unit.
- Furthermore the rules and regulations to avoid accidents are to be considered.

#### 2.1.2 Obligation of the operator

The Operator is obliged to only let personnel work with the unit who:

- Are familiar with the fundamental regulations of work safety and accident avoiding and who have been instructed how to operate the unit.
- Read and understood the chapter about safety and warning notes and have confirmed this with their signature.

The safe conscious operation of the personnel has to be examined regularly.

#### 2.1.3 Obligation of the personnel

All individuals who are authorized to work with the unit are obliged to:

- pay attention to the fundamental regulations of work safety and accident avoiding,
  - read the chapter on work safety and warning notes in this manual and to confirm through their signature that they have understood these,
- before actually operating the unit.

#### 2.1.4 Possible risks

The unit is built state of the art and in acknowledgement of all safety related rules. Nevertheless is it possible that danger for body and life of the user and/or third and/or impairments at the unit or at other real values merge. The unit is to be used only:

- For the due use.
- In safety related flawless condition.

Disturbances which can hurt the safety are to be eliminated immediately.

#### 2.1.5 Due use

The unit is built exclusively for the holding and presentation of food only. Any other uses of the unit are only allowed after consulting UBERT GASTROTECHNIK GMBH. Damages which result out of wrong use UBERT GASTROTECHNIK GMBH cannot be held responsible. Part of the due use is also:

- the consideration of all references of the operating manual and
- the observance of necessary maintenance and service.

## 2.2 Warranty and Liabilities

Fundamentally our "General terms of sale and delivery" count. These are known to the operator at the latest since signing of the contract. Claims to warranty and liability at persons- and property damages are impossible, if they are to be led back to one or several of the following causes:

- Non due use of the unit.
- Improper assembling, starting up, operating and servicing of the unit.
- Operating the unit with defective safety devices or safety devices which have not been installed properly and are in no working condition.
- Disobeyment of the references in the operating manual concerning transportation storage, installation, start-up, operation, maintenance and assembling of the unit.
- Unauthorized mechanical or electrical changes of the unit.
- Insufficient maintenance of wear and tear parts.
- Unauthorized repair.
- Force of nature and act of god.

Warranty claims can only be forwarded if the guarantee card has been signed and returned to UBERT GASTROTECHNIK GMBH. Detailed guarantee conditions can be found in the corresponding documentation supplied with the unit.

## 2.3 Symbols and Notes

In the operating manual the following symbols and signs are used:



This symbol means a possibly or directly threatening danger for the life and the health of persons and/or a possibly dangerous situation.  
*Ignoring of these references may result in consequences for your health and/or can lead to property damages!*



This symbol points to important references for the proper use of the unit.  
*Not paying attention to these references can lead to disturbances at the unit or in the environment!*



This symbol points to operation tips and especially useful information.  
*Help to use all functions at your unit optimally!*

## 2.4 Copyright

The copyright on this operating manual remains at the company UBERT GASTROTECHNIK GMBH. This operating manual is intended only for the operator and his personal. It contains instructions and references which neither completely nor partially:

- be duplicated,
- be circulated, or
- be otherwise made available to third parties.

Offences may violate applicable laws.



## 2.5 Special safety references

### 2.5.1 Safety devices

- Before operating the unit all protective devices as well as all removable parts must be installed correctly and be fully workable.
- Protective devices may only be removed:  
After stand still and the prevention of unintentional restart.
- If partial components are delivered, an authorized staff member or service technician has to execute assembly according to installation guidelines.

### 2.5.2 Informal safety steps

- The operating manual is to be kept constantly accessible in the operating area.
- In addition to the operating manual all generally acknowledged and all local regulations for accident avoiding and environmental protection have to be applied with.
- All safety- danger labels at the unit are to be kept in readable condition.

### 2.5.3 Education of the personal

- Only trained and instructed personal may work at the unit.
- The responsibilities of the personal are to be determined clearly for installing, start-up, operation, assembling, and servicing of the unit.
- During instruction the personal may only work at the unit under supervision of an experienced person.

### 2.5.4 Controls

- Only instructed personal is allowed to operate the controls.

### 2.5.5 Safety during regular operation

- The unit is only to operate if all protective devices are fully workable.
- At least once per shift the unit is to be examined with regard to visible damages and functional ability of the safety devices.

### 2.5.6 Danger caused by electric energy

- Any work on the electrical supply is to be executed only by a specialist.
- Likewise the electrical connection of this unit to the power supply must be executed by an electro-specialist; the connection must follow the rules of the local determinations.
- The electric installation is to be examined regularly. Loose connections and braised cables are to be eliminated immediately.
- If works at any life-parts are necessary, a second person who switches off the main switch if necessary is to consult.

### 2.5.7 Special danger-spots

- The glass shelves provide radiant heat up- and downwards and are hot at all time during regular operation hours!
- Do not touch the hot glass shelves!
- Do not touch the hot halogen lamps!
- Tilt the shelves only while the unit is cold!

### **2.5.8 Service and maintenance, troubleshooting**

- Prescribed adjustment, service and inspection work is to be accomplished timely by the manager or if necessary by an authorized service technician.
- The operating personal is to be informed before the beginning of the maintenance and service work.
- The unit is to be disconnected from the mains before maintaining, inspecting and repairing is performed; the main switch is to be guarded against unintended operation.
- Check all screw connections for tight fitting.
- After finishing maintenance check all safety devices for proper functionality.

### **2.5.9 Structural changes to the unit**

- Do not perform any changes, extensions or conversions to the unit without the manufacturer's permission, especially welding work at supporting parts.
- For all conversions a written permission of the company UBERT GASTROTECHNIK GMBH is necessary.
- Change all parts of the unit, which are in improper condition.
- Use only original spare parts.

### **2.5.10 Cleaning of the unit and disposal of the waste**

Used substances and materials are to be handled and disposed appropriately, especially lubricants. Detergents have to follow the rules of food-hygiene.

## 3 Introduction

### 3.1 Introduction

All Ubert Quick Serve Cabinets operate with smooth, radiant heat to minimize weight loss of the products. The temperature is regulated by energy controllers individually for each shelf. The optimized, smooth heat guarantees long holding times at low quality-loss. To optimize the product presentation, the cabinet is equipped with effective halogen lighting.



The maximum holding time depends on the kind of product and on the products starting temperature. It might be limited by national or local regulations. Never equip the cabinet with cold or deep frozen products.



### 3.2 Special features

- Ergonomically, stylish design
- Maximum product visibility
- Optically doubled food presentation by mirrored rear wall
- Decorative stand with bumpers
- Easy handling due to open design
- Optimized product-presentation by variable shelves.
- Meeting the hygienic requirements in accordance with HACCP
- All models are intended as self-service equipment for impulse buying



### 3.3 Technical details

#### 3.3.1 Dimensions [mm]

##### QS1:

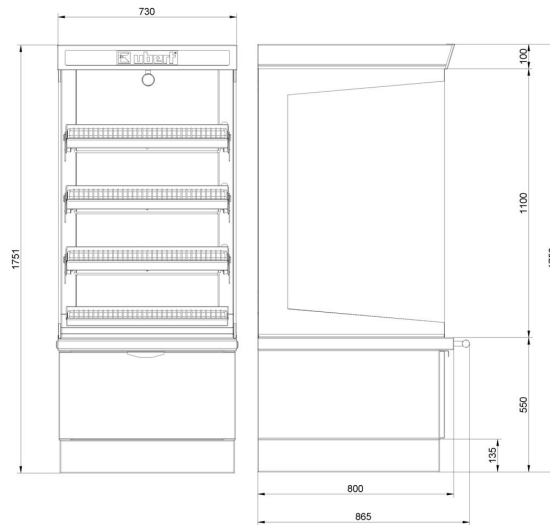

##### QS2:

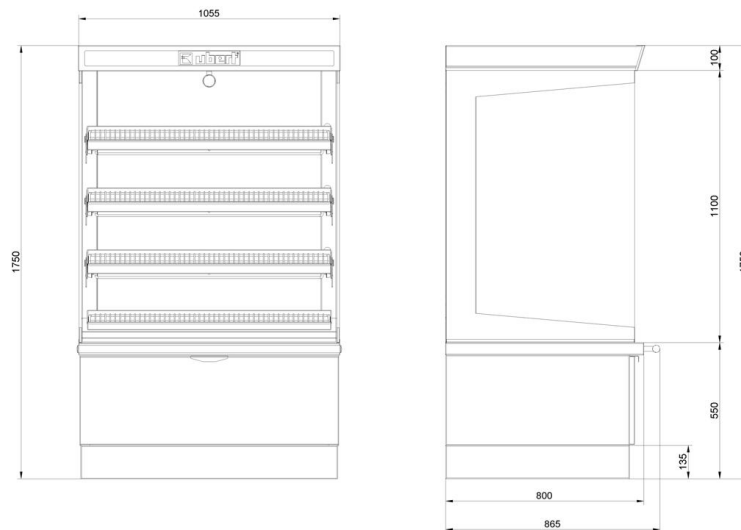

##### QS3:

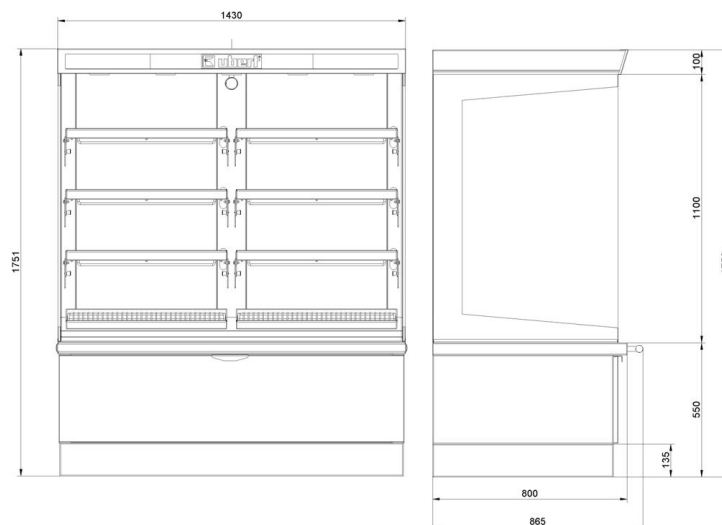

### 3.3.2 Weight

<u>Type</u>	<u>Weight</u>
QS1	ca. 150kg
QS1	ca. 175kg
QS3	ca. 200kg

### 3.3.3 Electrical Details, Power Consumption

<u>Type</u>	<u>el. connection [EA]</u>	<u>power consumption</u>
QS1	400V, 3/N, 50/60Hz	6.0kW
QS2	400V, 3/N, 50/60Hz	9.0kW
QS3	400V, 3/N, 50/60Hz	12.0kW

### 3.3.4 Noise emission

<u>Type</u>	<u>noise emission</u>
All types	< 70 dB (A)

## 4 Installation and putting into operation

In general all Quick Serve Cabinets will be packed for safely transport after the final control so that they will reach you properly. Nevertheless we ask you to have a look at the machine while unwrap it, whether it is really absolutely faultless.



**Note!** Visible faults have to be claimed immediately!

### 4.1 Unwrapping

- Open the carton and take out the wrapping material carefully.
- Take care that the delivery is complete (see attached freight papers).

### 4.2 Installation

Place the cabinet in the desired location. Make sure, that it is good visible for your customer to ensure good food presentation and successful sales.

Take care of the following points:

- The cabinet has to be placed on a horizontal level Use a spirit level if necessary.
- Take care that both sides have at least 10 cm clear space to enable cleaning of the side glasses.
- There has to be enough free space to load, unload, clean and maintain the unit.
- The machine has to be placed so that the complete area around it can be cleaned easily.



### 4.3 Electrical connection

**Note!** In general, only service technicians of the company UBERT GASTRO-TECHNIK GMBH or service technicians of your responsible service partner are allowed to perform el. connection and other service! All national and local rules and regulations concerning electricity, fire protection and the like have to be considered. During any servicing, take care that the unit is disconnected from the mains! Not paying attention may result in injury!



Please learn the electrical data of your unit from the nameplate.

- Check whether your local electrical power supply is in accordance with the values on the name plate.
- Make sure the supply cable is protected as listed below:  
5- wire, min. cross-section 1,5 mm<sup>2</sup> ) separately with 16 Amps.
- The power supply needs to be manufactured from heat resistant, flexible cable. It is to be routed to prevent any contact to hot parts.
- The unit is to be connected to the power supply either by means of an appropriate plug or if connected permanently, a switch (interrupting all poles) is to be provided. In case of an emergency the power supply must be interruptible immediately.
- For further information please see the wiring diagram (below).

**Note!**

After finishing any installation work, maintenance or repair, check whether the ground wires are connected properly to the casing and the side covers.



### 4.4 Preparation of Using / Starting up

Before you can use the Cabinet you have to clean all removable parts carefully with a grease solvent.

**Note!** Do not use flammable cleaners. Do not use high-pressure cleaning machines, water pressure cleaning machines or steam jet cleaning machines. You will have further information about this in the section „ cleaning and up keeping“.



After cleaning the Cabinet properly the smell will be minimal when using it the first time.

## 5 Operation

Following you will find explanation and location of all components and their function for the use of the cabinet.

### 5.1 Operator panel

To access the operator panel while standing in front of the unit, open the front cover by tilting it towards you as shown below.



Four energy controllers are provided for each vertical row of shelves.

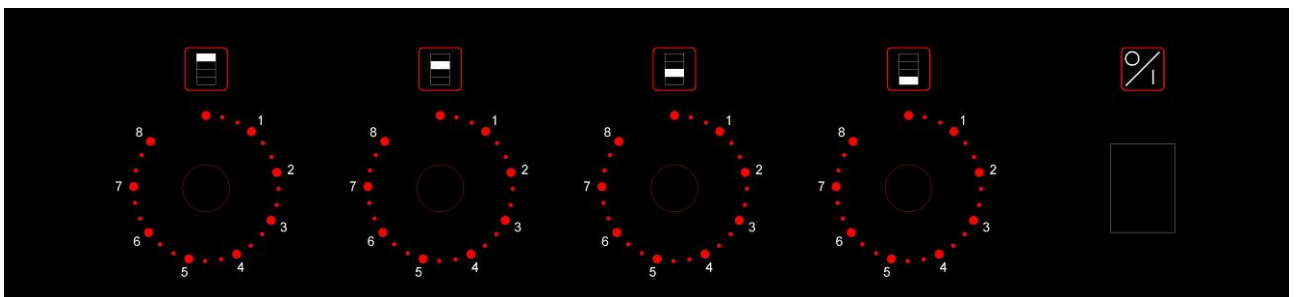

**ON/OFF-Switch:** Toggle to switch the unit and the lights on or off



**Energy Controller top shelf:** Turn the knob to adjust the heat for the top shelf in this row. The maximum adjustment is limited to 6.



**Energy Controller second shelf:** Turn the knob to adjust the heat for the top shelf in this row. The maximum adjustment is limited to 6.



**Energy Controller third shelf:** Turn the knob to adjust the heat for the top shelf in this row. The maximum adjustment is limited to 6.



**Energy Controller bottom shelf:** Turn the knob to adjust the heat for the top shelf in this row. The maximum adjustment is limited to 6.

## 5.2 Adjustment of the shelves

To adjust the inclination of a shelf, pull the knob on each side inwards and turn it 90°. Now the shelf can be tilted down to 15° in 3° steps. To fix the inclination turn the knobs back for 90°. Make sure they lock properly into the corresponding hole.

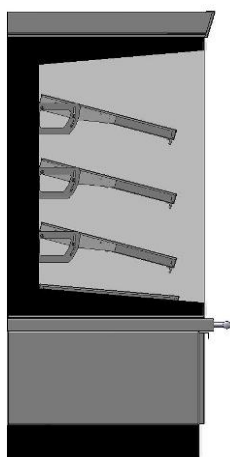
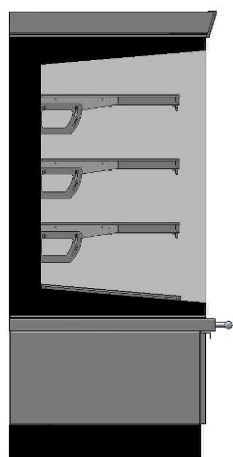
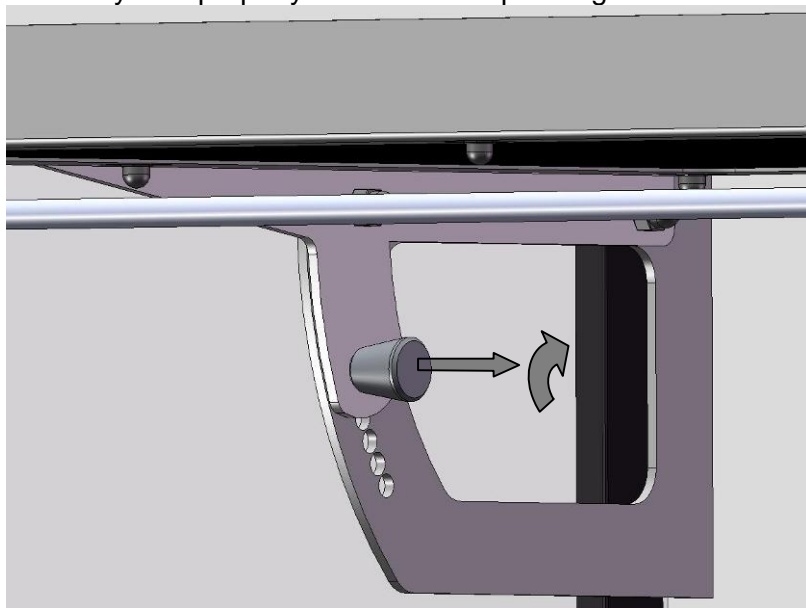

## 6 Maintenance

Following we will show you some advices concerning maintenance, care, trouble shooting and service for the cabinet.

### 6.1 Cleaning and care

#### 6.1.1 Safety advices

- Before you start to clean and care switch off the appliance and disconnect it from the mains.
- Do not use inflammable detergents cleaners. Never use high-pressure-, water pressure- or steam jet- cleaning machines. You will find further information in the chapter concerning cleaning.
- Wear fire safe, insulated gloves to prevent burnings when touching hot parts.
- Wear acid proof gloves while cleaning the cold parts to prevent skin irritations.



#### 6.1.2 General Recommendations

- The unit has to be cleaned daily!
- Only use cleaners that are appropriate for food.
- After cleaning with special cleaners you have to wash all parts with clear water and dry them afterwards so that there are no residues of the cleaner on these parts.
- It is absolutely necessary to watch out for some fundamental things to keep this long living high-grade-steel-machine working:
  - always keep the high-grade-steel surface clean
  - watch out that there is always enough fresh air on the surface
  - never contact the surface with rusty material.
- Never use bleaching or chlorine cleaners.



#### 6.1.3 Detergents

To make the cleaning fast and easy we have integrated some cleaners in our program:

- Grill- and oven cleaner:  
To dispose persistent, dried-up dirt on metal surfaces.
- Intensive-cleaner:  
Detergent for metal- and plastic-surfaces.
- Glass-cleaner:  
Removes fat from glass-surfaces.
- Stainless steel-cleaner:  
You have to spray this from a distance of app. 25 cm on the surface and wipe it off with a dry cleaning rag. If you want to clean only small parts you have to spray it directly on the cleaning rag and wipe it off this way. With this method it is possible to clean easily and without stripes.



#### 6.1.4 Special Cleaning tips

Please find below some special cleaning tips for this specific unit.

- Lamps:  
To be cleaned only with soft paper or cloth and alcohol.
- Grids:  
The grids are removable without tools for easy cleaning.
- Glass:  
Remove dust and dirt from the glass surfaces with soft cloth to avoid scratches.
- Base:  
In case the unit is equipped with a powder coated colour, make sure to use a non abrasive detergent that is suitable for such surfaces.





## 6.2 Trouble shooting

In case your cabinet does not work properly, we would like to give a first help with the following checklist. Only after checking these points you should contact:

a) Your responsible service partner

Or

b) Directly the company: UBERT GASTROTECHNIK GmbH  
Werk II Gewerbegebiet Nord  
Vennekenweg 17  
46348 Raesfeld  
Tel: (49) 02865 / 602-226  
Service-Tel: 0172 / 2 82 86 31  
Fax: (49) 02865 / 602-102 (or -103)

Only these two companies are allowed to carry out service work and replacement of defect parts. If you do not observe this note or in case of manipulation of a third party any claims for guarantee will become invalid!



### Checklist for Quick Serve Cabinet:

1. Is the unit wired properly and connected to the mains?
2. Does the wall socket provide the required current / voltage (see the nameplate for details)?
3. Does the fuse protection work properly?
4. Do all heating elements of the unit work properly?
5. Do all lamps and infrared heaters work properly?  
Check lamps and infrared heaters connection!

### 6.3 Wiring Diagrams

#### 6.3.1 QS1

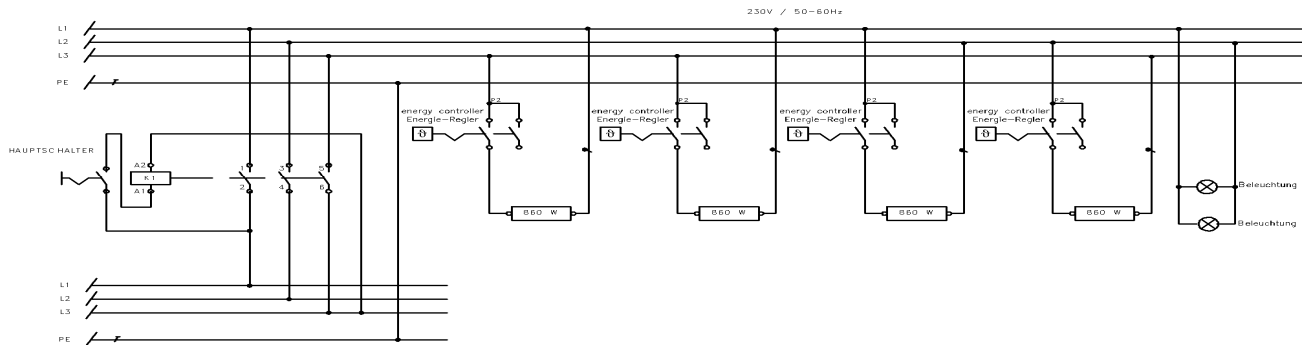

#### 6.3.2 QS2

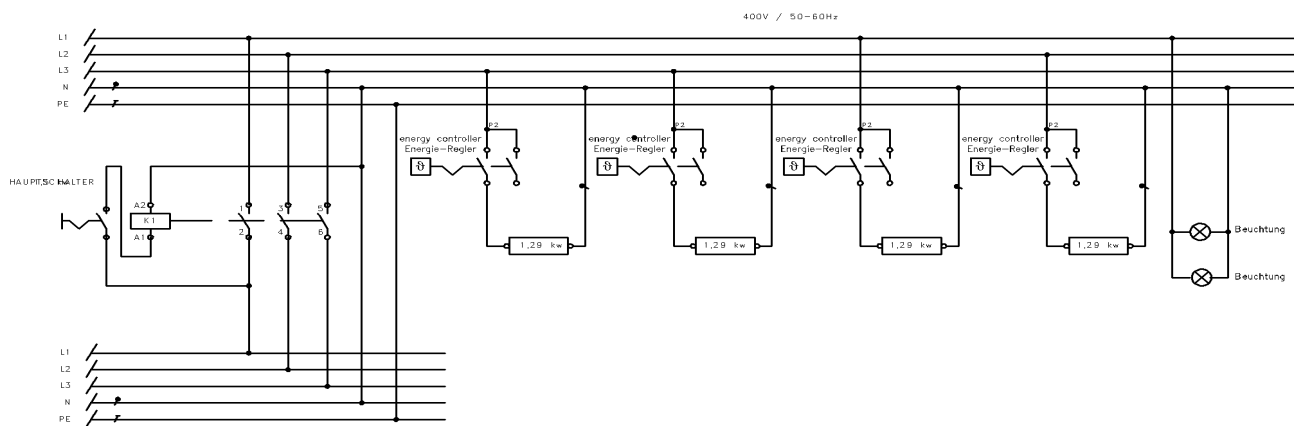

#### 6.3.3 QS3

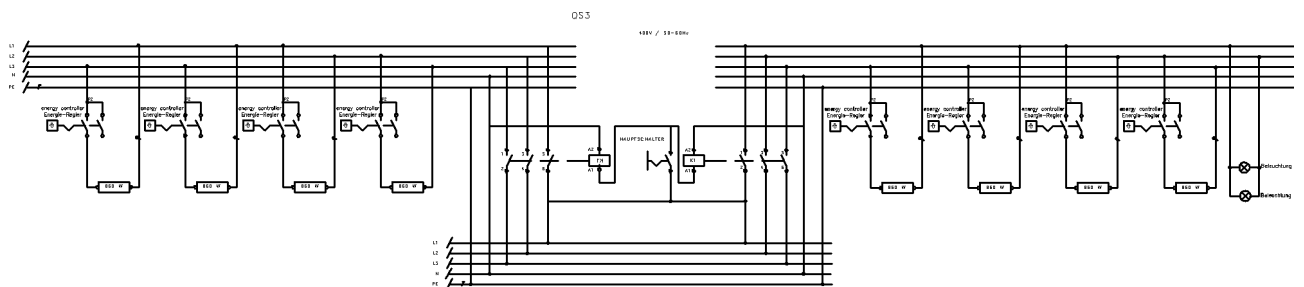







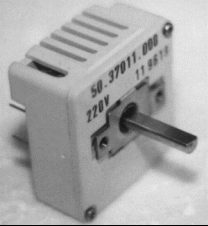
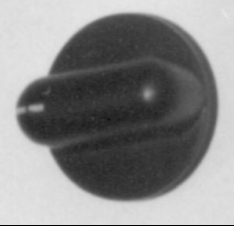
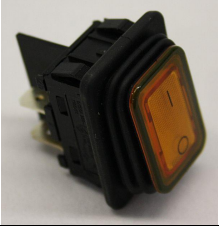

## 6.4 Spare Parts

Defect parts are to be replaced only by original spare parts of the company UBERT GASTROTECHNIK GMBH; the replacement is to be carried out only by their service personal or by your authorized Service companies. Only these two companies are allowed to carry out service work and replacement of defect parts. If you do not observe this note or in case of manipulation of a third party any claims for guarantee will become invalid! Also all certifications (CE, UL, NSF and the like) become invalid!

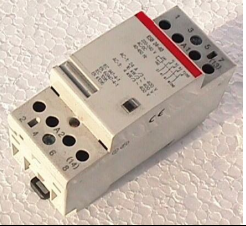

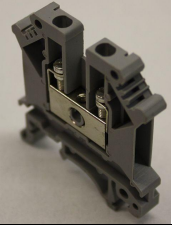
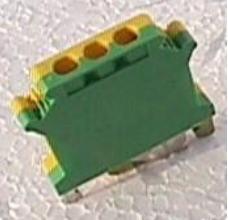
### 6.4.1 Spare part pictures

<p><b>107801</b></p> 	<p><b>107803</b></p> 	<p><b>370140</b></p> 
<p><b>341141</b></p> 	<p><b>361311</b></p> 	<p><b>341111</b></p> 
<p><b>338102</b></p> 	<p><b>380734</b></p> 	<p><b>342408</b></p> 
<p><b>338104</b></p> 	<p><b>338105</b></p> 	<p><b>333349</b></p> 
<p><b>333345</b></p> 	<p><b>333362</b></p> 	<p><b>341315</b></p> 

<p><b>340308</b></p> 		<p><b>340310</b></p> 		<p><b>342964</b></p> 
<p><b>342963</b></p> 		<p><b>113048</b></p> 		<p><b>311915</b></p> 
<p><b>313916</b></p> 		<p><b>340628</b></p> 		<p><b>342915</b></p> 
<p><b>361508</b></p> 		<p><b>370235</b></p> 		

## 6.4.2 Spare Parts List

### QS1

Amount	Part No.	Description	VT
4	107801	heating element frame incl. glass for QS1/ QS3	X
8	370140	Lock bolt	
4	341141	energy controller	
4	361311	Knob	
1	341111	rocker switch orange 2 pol.	
1	338102	Stain relief counter nut	
8	380734	cage nut	
1	342408	main contactor	
1	338104	Strain relief	
1	338105	Stain relief, counter nut M20,brass	
21	333349	Terminal block UK5	
5	333345	Ground terminal block	
11	333362	Cap Type D UK 4/10	
1	341315	Plug, angled, 5-pole 16A,red	
3	340308	Halogen lamp	
3	340310	Lamp spotlight 20Watt 12V	X
4	342964	heating element	
8	113048	GN-rust 1/1 for Quick Serve	
2	311915	Screw Rampa, M6 RF 613 Ms	
12	313916	Screw DIN923 M6x5 A2	
1	340628	Transformer, 12 V/35-110 VA	
1	342915	Thermometer 0-110°C	
12	361508	flange - Teflon, black	
1	370235	Magnetic lock	

### QS2

Amount	Part No.	Description	VT
4	107803	heating element frame incl. glass for QS2	X
8	370140	Lock bolt	
4	341141	energy controller	
4	361311	Knob	
1	341111	rocker switch orange 2 pol.	
1	338102	Stain relief counter nut	
8	380734	cage nut	
1	342408	main contactor	
1	338104	Strain relief	
1	338105	Stain relief, counter nut M20,brass	
21	333349	Terminal block UK5	
5	333345	Ground terminal block	
11	333362	Cap Type D UK 4/10	
1	341315	Plug, angled, 5-pole 16A,red	
3	340308	Halogen lamp	
3	340310	Lamp spotlight 20Watt 12V	X
4	342966	heating element	

12	113048	GN-rust 1/1 for Quick Serve	
2	311915	Screw Rampa, M6 RF 613 Ms	
12	313916	Screw DIN923 M6x5 A2	
1	340628	Transformer, 12 V/35-110 VA	
1	342915	Thermometer 0-110°C	
12	361508	flange - Teflon, black	
1	370235	Magnetic lock	

### QS3

Amount	Part No.	Description	VT
8	107801	heating element frame incl. glass for QS1/ QS3	X
16	370140	Lock bolt	
8	341141	Energy controller	
8	361311	Knob	
1	341111	Rocker switch orange 2 pol.	
2	338102	Stain relief counter nut	
16	380734	Cage nut M4	
2	342408	Main contactor	
2	338104	Stain relief	
2	338105	Stain relief, counter nut M20,brass	
42	333349	Terminal block UK5	
10	333345	Ground terminal block	
22	333362	Cap Type D 4/10	
2	341315	Plug, angled, 5-pole,16A, red	
5	340308	Halogen lamp	
5	340310	Lamp spotlight 20Watt 12V	X
8	342964	Heating element	
16	113048	GN-rust 1/1 for Quick Serve	
2	311915	Screw Rampa, M6 RF 613 Ms	
24	313916	Screw DIN923 M6x5 A2	
1	340628	Transformer, 12 V/35-110 VA	
2	342915	Thermometer 0-110°C	
12	361508	flange - Teflon, black	
1	370235	Magnetic lock	

## 6.5 Declaration of Conformity

UBERT GASTROTECHNIK GMBH  
Gewerbegebiet Ost + Nord  
D-46348 Raesfeld

Telefon: +49 (0) 28 65 / 602-0  
Fax: +49 (0) 28 65 / 602-102  
Internet: www.ubert.com  
e-mail: info@ubert.com



# CE KONFORMITÄTSERKLÄRUNG DECLARATION OF CONFORMITY CERTIFICAT DE CONFORMITÉ

Hereby we declare that the unit noted below, on the basis of its concept, design and version, meets all basic health and safety requirements of the applicable EC-directive. This declaration is no longer effective in case this machine has been modified without our approval.

**Product designation:** Quick Serve .....

**Model:** QS1 / QS2 / QS3 .....

**EC-directives followed:** EC-directive for machines: 2006/42/EG .....

EC-directive for low voltage: 2006/95/EG .....

Electromagnetic compatibility: 2004/108/EG .....

**Harmonized European Standards:** EN 55014 Electromagnetic compatibility – Requirements for household appliances .....

EN 61000-6-2 Electromagnetic compatibility – Generic immunity standard .....

EN 60335-1 Safety of household and similar electrical appliances .....

EN 60335-2 Safety of household and similar electrical appliances .....

**Applied national standards and technical specifications:** BGR111 directions for safety and health protection regarding kitchen work .....

VDE 0700 Safety of household and similar electrical appliances .....

This declaration does not include any assurance of characteristics.

The safety references enclosed with the product documentation have to be followed.

By internal actions it is guaranteed, that all serial units meet the demands of the corresponding EC directive and the applied standards.

The signers are entitled to compose the technical documents.

Raesfeld, 01.01.10  
UBERT GASTROTECHNIK GMBH

Christoph Stephan  
Vice President, R&D / Engineering

Raesfeld, 01.01.10  
UBERT GASTROTECHNIK GMBH

Michael Peters  
Service - Manager

Manufactured by: UBERT GASTROTECHNIK GMBH  
Gewerbegebiet Ost + Nord  
D-46348 Raesfeld