

# SILO



## S350

Ice Bin for Modular Ice Machines

SKOPE®

ITV  
ICE makers



### Features



- 340kg ice storage capacity
- Strong solid AISI 304 stainless steel box-type frame
- Very hard sanitary polythylene vat, resistant to blows and scratches
- Easy cleaning design: seamless one-piece vat with rounded corners, avoiding possible dirty points and facilitating cleaning
- Drainage system that collects and drives the water to the drain keeping the bin clean and dry

### Machine Specifications

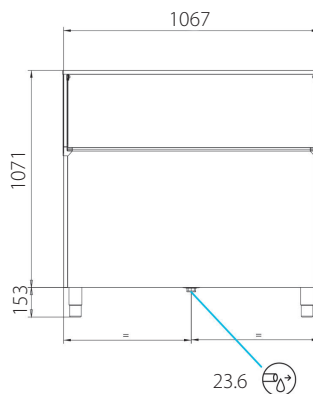
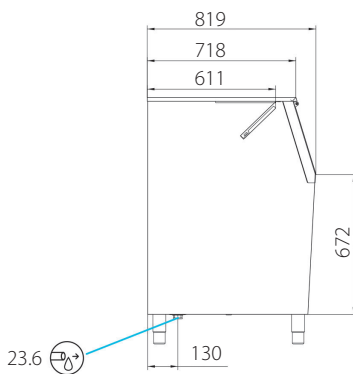

**Machine dimensions** 1067 x 819 x 1071mm/1224 with legs

**Packed dimensions** 1150 x 890 x 1210mm

**Weight** 69kg

**Floor area** 1.24m<sup>2</sup>

**Storage bin capacity** 340kg

all measurements in mm

### Supplied Accessories



Drain Hose



Drainage Elbow



Large Scoop



4 Height Adjustable Leg Kit

### Water Filter

A Watermark approved\* water filter, suitable for the water type at the place of installation must be used. SKOPE can provide a water filter that protects the Ice Maker, and ensures proper function and high quality ice production. Service or repair due to absence of a suitable water filter will not be covered by SKOPE warranty. Contact SKOPE for more information.

\*Watermark approval is only applicable to Australian installations.

Elsewhere, a suitable water filter must be used.