

# specifications

## PG550 Prep-2

SKOPE Gen2 Pegasus Horizontal 1/1  
INTEGRAL 4 Door Prep Chiller (JH7304)



### CABINET DIMENSIONS

|             | External           | Internal |
|-------------|--------------------|----------|
| Height:     | 751mm*             | 570mm    |
| Width:      | 2267mm             | 1769mm   |
| Depth:      | 700mm              | 545mm    |
| Floor area: | 1.59m <sup>2</sup> |          |

\* Height excludes castors or legs.

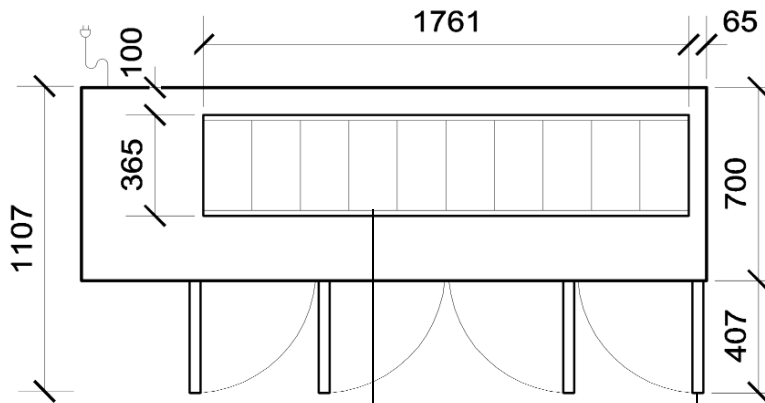

Side Mounted Integral  
Refrigeration Unit

10 x 1/3 150mm  
deep pans

Solid Swing Doors

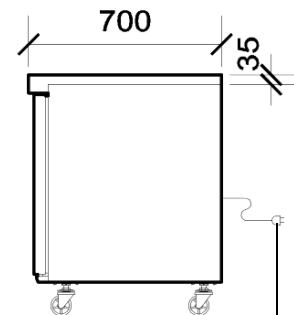
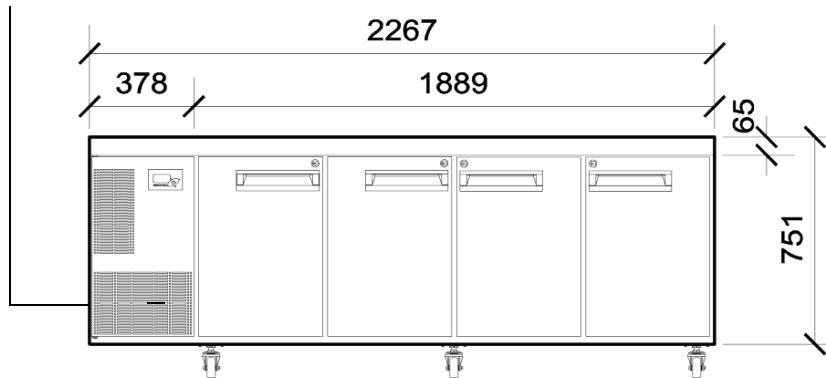

Power Cord with 3-Pin Plug

Copyright © 2008 SKOPE Industries Limited

### CABINET SPECIFICATIONS

|                             |  |
|-----------------------------|--|
| Refrigeration system:       | Electronic controlled, side mounted, integral refrigeration unit           |
| Electronic controller:      | CAREL ir33 electronic controller   |
| Refrigerant:                | R134a / 800g   |
| Nominal capacity:           | 706 Watts  |
| Cabinet internal volume:    | 560 litres   |
| Insulation:                 | 60mm thick, high density cyclo-isopentane polyurethane foam                |
| Cabinet temperature range:  | +1°C to +5°C up to 30°C ambient  |
| Drainage:                   | No plumbing required   |
| Electrical:                 | 230-240 Volts a.c. 50 Hz, 5.26 Amps  |
| Internal lighting:          | 2 x 5W T8 LED tubes (Ø26 x 360mm) - Door activated                         |
| Internal door opening size: | 4 door openings: 570mm high x 365mm wide                                   |
| Doors:                      | Solid stainless steel, self-closing doors (with key lock) - LH & RH hinged |
| Worktop (optional):         | Accepts 10 x 1/3 150mm deep pans or 20 x 1/6 150mm deep pans               |
| Shelves:                    | Two levels of non-tip, adjustable tray slides and/or shelves per door      |
| Weight:                     | 175 kg   |

SKOPE Industries Limited reserve the right to alter specifications without notice.

PSS0193 Rev 5.0 Jul. 2014



SKOPE INDUSTRIES LIMITED



New Zealand Freephone: 0800 947 5673, Fax: (03) 983 3896. Australian Freephone: 1800 121 535, Freefax: 1800 121 533

Email: enquiry@skope.co.nz Website: www.skope.co.nz