

Panasonic

**COMMERCIAL FOOD SERVICES
PRODUCT CATALOGUE**

2023



hussmann.com.au/food-service/





Our range of
commercial
Food service
products from
Panasonic

Whilst you are probably aware of the Panasonic brand, what you probably didn't know is that Panasonic have been supplying commercial kitchens with products for over 50 years. We have been supplying international customers with a wide range of Commercial Food Service products, specifically designed to meet the needs of the Hospitality industry.

Based on our success globally including Europe, North America, Japan, China and other parts of Asia, Panasonic is now bringing some of these ranges to Australia and New Zealand for the Food Service and Hospitality market.

Panasonic has a long history of producing quality products and in 2018 celebrated our 100 year anniversary since foundation. This longevity has been built on the back of long relationships with the market and working pro-actively with our customers to build a better future. The Commercial Food Services division has a dedicated B2B team that will manage the launch of an exciting new future for the Panasonic brand.

We will be talking to you, our customers, on expanding the range in the future and hope you enjoy using our products.



Content

EE Max Display Cases
VERTICAL CHILLED DOOR UNITS

06

Grab-n-Go
MULTI DECK AND SEMI VERTICAL

10

Commercial Refrigerators
HP SERIES UPRIGHT & UNDER BENCH

16

Commercial Freezers
HP SERIES UPRIGHT & UNDER BENCH

24

Microwaves
LIGHT, MEDIUM, HEAVY, CONVECTION

29

Rice Cookers
LID AND HINGED

37



Introducing the New EE Max Series

Strong cabinet with
metallic inner liner

Perfect solution for high
temperature and high
humidity climate conditions

Frequency controlled
Electronic thermostat



EC fans

High Efficiency
Inverter Technology

EE Max Range

Environmentally friendly
Natural Refrigerant

Vertical Display & Storage



Single Door Solution – BV520 W VS

EXTERNAL DIMENSIONS	W680 x D652 x H2200mm
INTERNAL DIMENSIONS	W575 x D500 x H1675mm
GROSS/NET VOLUME (LT)	519 / 467
330 ML CAN LOADING (MAX)	684
500 ML BOTTLE LOADING (MAX)	344
FACING	8
TRANSPORT CONTAINER 40 HC * With extended aluminum handle	51



*Supplied black internal, black external



Single Door Solution – BV770 W VS

EXTERNAL DIMENSIONS	W800 x D725 x H2200mm
INTERNAL DIMENSIONS	W720 x D570x H1685mm
GROSS/NET VOLUME (LT)	728 / 678
330 ML CAN LOADING (MAX)	978
500 ML BOTTLE LOADING (MAX)	489
FACING	10
TRANSPORT CONTAINER 40 HC * With extended aluminum handle	42

*Supplied black internal, black external



LED Illumination



Eco-Friendly Refrigeration



Tropical Class

INVERTER

Vertical Display & Storage

Double Door Solution – BV1300 W VS



EXTERNAL DIMENSIONS	W1200 x D764 x H2200mm
INTERNAL DIMENSIONS	W1125 x D622 x H1571mm
GROSS/NET VOLUME (LT)	1142 / 1088
330 ML CAN LOADING (MAX)	1306
500 ML BOTTLE LOADING (MAX)	674
FACING	16
TRANSPORT CONTAINER 40 HC * With extended aluminum handle	24



Double Door Solution – BV1600 W VS



EXTERNAL DIMENSIONS	W1600x D724 x H2200mm
INTERNAL DIMENSIONS	W1500 x D623 x H1545mm
GROSS/NET VOLUME (LT)	1455 / 1326
330 ML CAN LOADING (MAX)	1828
500 ML BOTTLE LOADING (MAX)	912
FACING	22
TRANSPORT CONTAINER 40 HzC * With extended aluminum handle	21



LED Illumination



Eco-Friendly Refrigeration



Tropical Class

INVERTER

Vertical Display & Storage

Customised corporate options available on request



Strong
Metallic
Inner Liner



LED
Illumination



Eco-Friendly
Refrigeration



Tropical
Class



Grab'n Go

Self-contained

Multi use Open Front

Slow Release
Night Blinds Included

Available in
Various Widths



3M1 Temperature
Class - Suitable for
Food and Beverage use.

R290 Refrigerant



Grab'n Go Cabinets - H1T

Self contained multideck chiller-open

H1TMS | Height 2070 mm | Standard Depth 860 mm



H1TMS -10 | Available in Black or Silver

TOTAL LENGTH (mm)	NET VOLUME (L)	DISPLAY AREA (m2)	AMPERES (Amps)
1034	635	1.36	10



H1TMS -14 | Available in Black or Silver

TOTAL LENGTH (mm)	NET VOLUME (L)	DISPLAY AREA (m2)	AMPERES (Amps)
1344	844	1.81	15



H1TMS -19 | Available in Black or Silver

TOTAL LENGTH (mm)	NET VOLUME (L)	DISPLAY AREA (m2)	AMPERES (Amps)
1969	1266	2.71	20



H1TMS -26 | Available in Black or Silver

TOTAL LENGTH (mm)	NET VOLUME (L)	DISPLAY AREA (m2)	AMPERES (Amps)
2594	1689	3.62	20



Forced Evaporation



220-240V/50HZ Single Phase



Castors Standard H1TMS -19 & H1TMS -26



LED Lighting



2 Year Parts & Labour Warranty



Night Blinds

Grab'n Go Cabinets - H1T

Self contained multideck chiller-Door

H1TMDS | Height 2070 mm | Standard Depth 860 mm



Forced Evaporation



220-240V/50HZ Single Phase



Castors Standard H1TMS -19 & H1TMS -26



LED Lighting



2 Year Parts & Labour Warranty



H1TMDS -10 | Available in Black or Silver

TOTAL LENGTH (mm)	NET VOLUME (L)	DISPLAY AREA (m2)	AMPERES (Amps)
1034	635	1.36	10



H1TMDS -14 | Available in Black or Silver

TOTAL LENGTH (mm)	NET VOLUME (L)	DISPLAY AREA (m2)	AMPERES (Amps)
1334	844	1.81	10



H1TMDS -19 | Available in Black or Silver

TOTAL LENGTH (mm)	NET VOLUME (L)	DISPLAY AREA (m2)	AMPERES (Amps)
1969	1266	2.71	10



H1TMDS -26 | Available in Black or Silver

TOTAL LENGTH (mm)	NET VOLUME (L)	DISPLAY AREA (m2)	AMPERES (Amps)
2594	1689	3.62	15

Multideck Chiller | H1TMS - Open

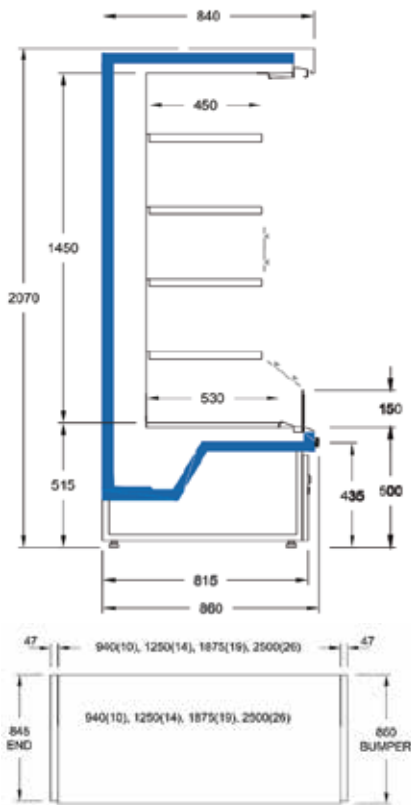

Product Benefits

- Ergonomic design for easy product access
- Adjustable shelving options to optimise merchandising
- Optimised display with LED lighting
- Low Total Energy Consumption (TEC)
- Product temperature compliance
- Easy plug-in on-site installation



Multideck Chiller | H1TMDS - Door

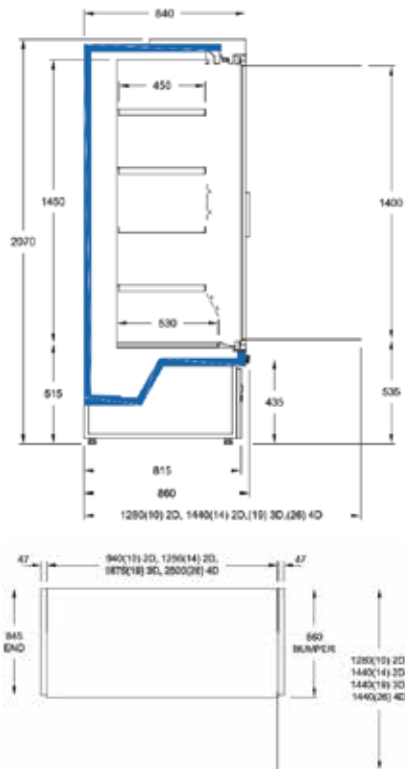

Product Benefits

- Ergonomic design for easy product access
- Adjustable shelving options to optimise merchandising
- Optimised display with LED lighting
- Low Total Energy Consumption (TEC)
- Product temperature compliance
- Easy plug-in on-site installation

Grab'n Go Cabinets - SGN



Low height Open Display Cabinet

SGN141S* | Height 1400 mm | Standard Depth 720 mm

DIMENSIONS	CAPACITY	WEIGHT
W650 x D720 x H1400mm	189L	90kg

* Shelf Dividers and Shelf Mats sold as optional extras

* Divider Code SGN141-0030 Gravity Feed Kit



Internal & External Powder Coating



Ticket Strips



Galvanised Base



Digital Controller



Night Blinds



LED Lighting



2 Year Parts & Labour Warranty



Self Contained Open Front Semi-Vertical Chiller

SGN152S | Height 1500 mm | Standard Depth 760 mm

	TOTAL LENGTH (mm)	NET VOLUME (L)	DISPLAY AREA (m2)	AMPERES (Amps)
SGN152S-1	1017	345	1.46	10
SGN152S-2	1330	460	1.81	10
SGN152S-3	1995	690	2.72	10
SGN152S-C	1530	530	2.10	10



Self Contained Semi-Vertical Chiller with doors

SGND153S | Height 1500 mm | Standard Depth 760 mm

Available in hinged and sliding

	TOTAL LENGTH (mm)	NET VOLUME (L)	DISPLAY AREA (m2)	AMPERES (Amps)
SGND153S-1	1017	400	1.46	10
SGND153S-2	1330	540	1.81	10
SGND153S-3	1955	805	2.72	10
SGND153S-C	1530	625	2.10	10

* Q4- Swing Door

* Q5- Sliding Door



Grab'n Go Cabinets - SGN

SGN141S

Low height open display cabinet

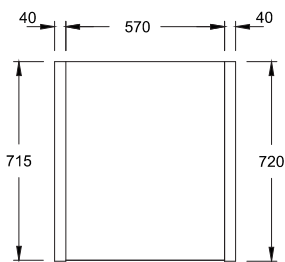
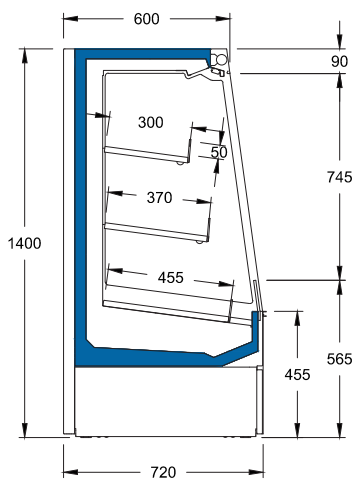

SGN152S

Self Contained Open Front Semi-Vertical Chiller

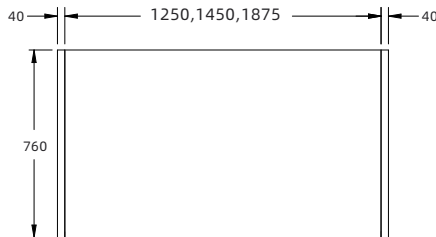
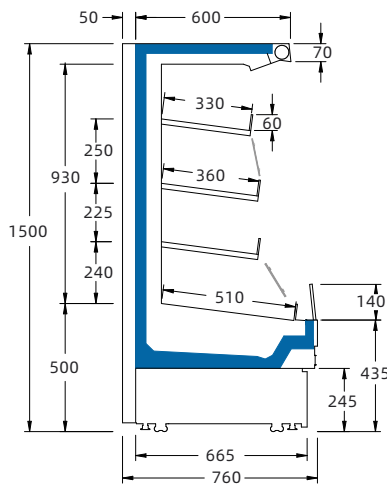

SGND153S

Self Contained Semi-Vertical Chiller with doors

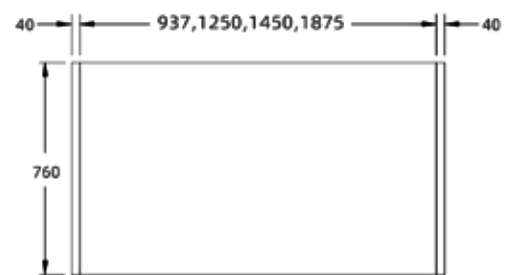
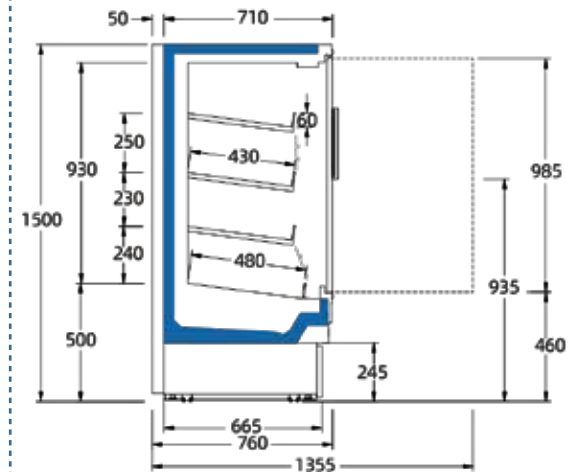

Product Benefits

- Ergonomic design for easy product access
- Adjustable shelving options to optimise merchandising
- Optimised display with LED canopy lighting
- Low Total Energy Consumption (TEC)
- Product temperature compliance
- Easy plug-in on-site installation
- Slim profile to fit with grocery racking
- Environmentally friendly R290 refrigerant

Commercial Refrigerators

HP SERIES UPRIGHT & UNDERBENCH

Tested in 43 °C Environment

Single Phase | 10Amp
(Easy Installation)



Pillarless Design

- Effective utilisation of full space
- Large items can be stored easily

Smaller Size but
Larger Capacity

Standard Equipped Forced
Evaporation System

Various Width on
Single Door Split and
2 Door Split



Upright Commercial Refrigerators



Centre-Pillarless Design



Forced Evaporation



220-240V/50HZ Single Phase



Heater Defrost



Castors Standard (Legs Optional)



2 Year Parts & Labour Warranty



Product Lockable

SINGLE SPLIT DOOR

SRR-681HP(AUH)

DIMENSIONS	CAPACITY	WEIGHT
W620 x D800 x H1995mm*	483L	105kg

SINGLE SPLIT DOOR

SRR-781HP(AUS)

DIMENSIONS	CAPACITY	WEIGHT
W745 x D800 x H1995mm*	610L	110kg



2 DOOR SPLIT DOOR

SRR-1281HP(AUH)

DIMENSIONS	CAPACITY	WEIGHT
W1210 x D800 x H1995mm*	1080L	160kg

2 DOOR SPLIT DOOR

SRR-1581HP(AUH)

DIMENSIONS	CAPACITY	WEIGHT
W1460 x D800 x H1995mm*	1329L	180kg



3 DOOR SPLIT DOOR

SRR-1881HP(AUH)

DIMENSIONS	CAPACITY	WEIGHT
W1800 x D800 x H1995mm*	1669L	200kg



* Heights shown are with Castors.

Underbench Commercial Refrigerators

2 DOOR TYPE

SUR-1261HP(AUH)

SLIMLINE TYPE



DIMENSIONS	CAPACITY	WEIGHT
W1200 x D600 x H850mm*	214L	78kg

2 DOOR TYPE

SUR-1271HP(AUH)

LARGE CAPACITY TYPE



DIMENSIONS	CAPACITY	WEIGHT
W1200 x D750 x H850mm*	280L	84kg

2 DOOR TYPE

SUR-1561HP(AUH)

SLIMLINE TYPE



DIMENSIONS	CAPACITY	WEIGHT
W1500 x D600 x H850mm*	296L	86kg

2 DOOR TYPE

SUR-1571HP(AUH)

LARGE CAPACITY TYPE



DIMENSIONS	CAPACITY	WEIGHT
W1500 x D750 x H850mm*	393L	95kg

3 DOOR TYPE

SUR-1861HP(AUH)

SLIMLINE TYPE



DIMENSIONS	CAPACITY	WEIGHT
W1800 x D600 x H850mm*	377L	99kg

3 DOOR TYPE

SUR-1871HP(AUH)

LARGE CAPACITY TYPE

DIMENSIONS	CAPACITY	WEIGHT
W1800 x D750 x H850mm*	495L	110kg



Centre-Pillarless Design



Forced Evaporation



220-240V/50Hz Single Phase



Heater Defrost



Castors Standard (Legs Optional)



LED Lighting



2 Year Parts & Labour Warranty



Product Lockable

Underbench Fridges with Glass Doors

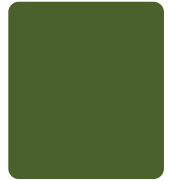

Centre-Pillarless Design



Forced Evaporation



220-240V/50HZ Single Phase



Heater Defrost



Castors Standard (Legs Optional)



2 Year Parts & Labour Warranty



Product Lockable

UNDERBENCH GLASS DOORS

BR-1261HP(AUH)

SLIMLINE TYPE

DIMENSIONS	CAPACITY	WEIGHT
W1200 × D600 × H850mm*	214L	88Kg



UNDERBENCH GLASS DOORS

BR-1271HP(AUH)

LARGE CAPACITY TYPE

DIMENSIONS	CAPACITY	WEIGHT
W1200 × D750 × H850mm*	280L	94Kg

UNDERBENCH GLASS DOORS

BR-1561HP(AUH)

SLIMLINE TYPE

DIMENSIONS	CAPACITY	WEIGHT
W1500 × D600 × H850mm*	296L	96Kg



UNDERBENCH GLASS DOORS

BR-1571HP(AUH)

LARGE CAPACITY TYPE

DIMENSIONS	CAPACITY	WEIGHT
W1500 × D750 × H850mm*	393L	105Kg

UNDERBENCH GLASS DOORS

BR-1861HP(AUH)

SLIMLINE TYPE

DIMENSIONS	CAPACITY	WEIGHT
W1800 × D600 × H850mm*	377L	114Kg



UNDERBENCH GLASS DOORS

BR-1871HP(AUH)

LARGE CAPACITY TYPE

DIMENSIONS	CAPACITY	WEIGHT
W1800 × D750 × H850mm*	495L	125Kg

* Heights shown are with Castors.

Underbench Fridges with Drawers



UNDERBENCH SOLID DOORS

SUR-1271HP(AUH)-NN

DRAWER TYPE

DIMENSIONS	CAPACITY	WEIGHT
W1200 × D750 × H850mm*	91L	94Kg



UNDERBENCH SOLID DOORS

SUR-1871HP(AUH)-NNN

DRAWER TYPE

DIMENSIONS	CAPACITY	WEIGHT
W1800 × D750 × H850mm*	155L	125Kg

UNDERBENCH SOLID DOORS

SUR-1571HP(AUH)-NN

DRAWER TYPE

DIMENSIONS	CAPACITY	WEIGHT
W1500 × D750 × H850mm*	138L	105Kg



UNDERBENCH SOLID DOORS

SUR-1871HP(AUH)-DWW DOOR & DRAWER TYPE

DIMENSIONS	CAPACITY	WEIGHT
W1800 × D750 × H850mm*	267L	140Kg



UNDERBENCH SOLID DOORS

SUR-1271HP(AUH)-DW

DOOR & DRAWER TYPE

DIMENSIONS	CAPACITY	WEIGHT
W1200 × D750 × H850mm*	185L	99Kg

SUR-1571HP(AUH)-DW

DOOR & DRAWER TYPE

DIMENSIONS	CAPACITY	WEIGHT
W1500 × D750 × H850mm*	264L	110Kg



Centre-Pillarless Design



Castors Standard (Legs Optional)



2 Year Parts & Labour Warranty



Product Lockable

Drawer Series GN Basin Layout



Pizza/Salad Prep Bench

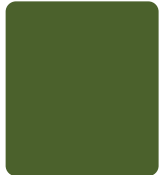

**COMING
SOON**



Centre-Pillarless Design



Forced Evaporation



220-240V/50HZ Single Phase



Heater Defrost



Castors Standard (Legs Optional)



LED Lighting



2 Year Parts & Labour Warranty

PIZZA/SALAD PREP BENCH SUR-1871HPZ-(AUH)

DIMENSIONS	CAPACITY	WEIGHT
W1800 × D750 × H1030mm*	495L	140Kg

KEY FEATURES

- No centre pillar for large item storage
- High-quality stainless steel
- Smaller size but larger capacity
- Operational under 43°C
- Designed for easy cleaning
- Anti-bacteria handles and shelves
- Detachable refrigeration system
- Wide temperature setting (-8~+10°C)
- Single metal top cover for easy operation
- Removable 300mm x 15mm thick cutting board
- Castors as standard
- 2 year parts and labour warranty
- 2 Part top cover
- Insulated Hinged lid

Bottom shelf for better air flow



Round corners for easy cleaning



* Heights shown are with Castors.

HP SERIES COMMERCIAL FREEZER (UPRIGHT TYPE)

Pillarless Design

- Smooth in & out
- Effective utilisation of full space
- Large items can be stored easily

Standard Equipped Forced Evaporation System

All Single Phase 220-240V Model (Easy Installation)

Various Width on Single Door Split and 2 Door Split

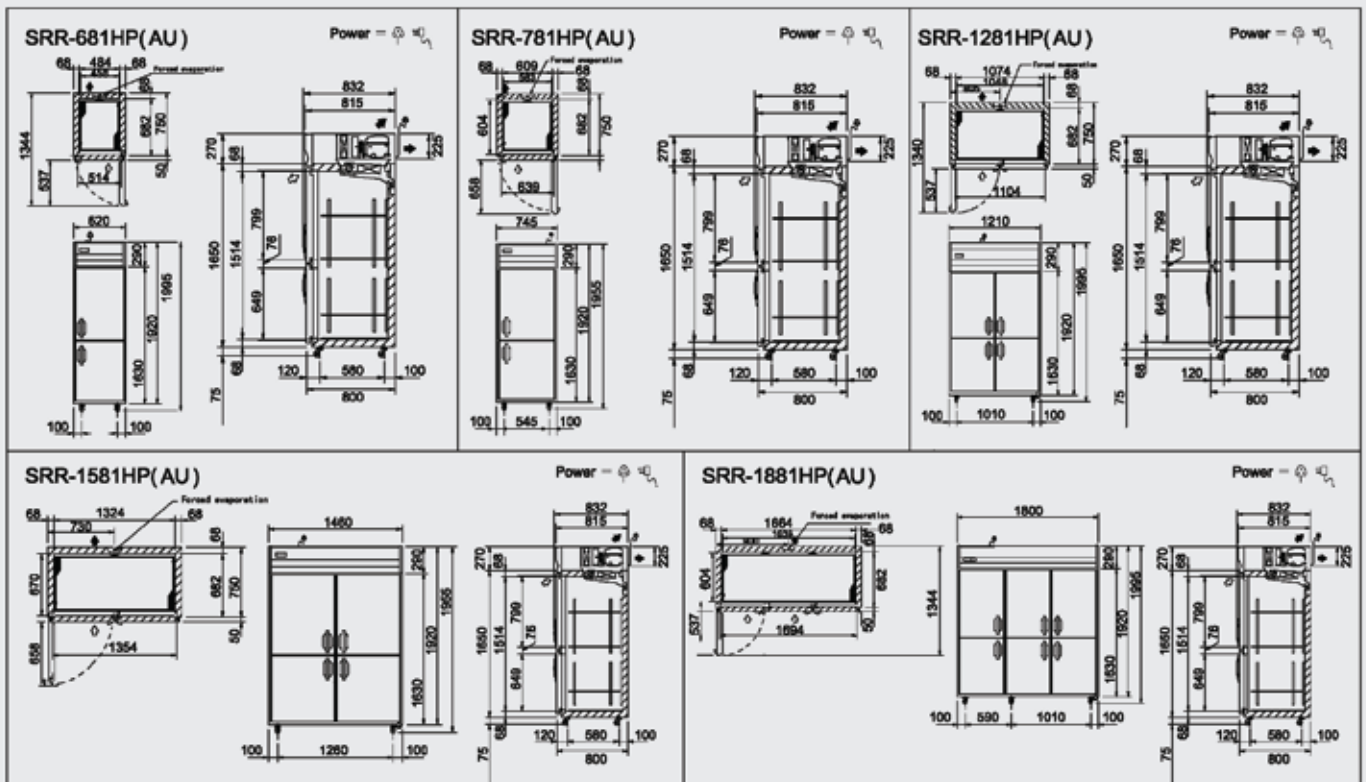

All four of our products in this category are designed for commercial use.

- Please consult the operation & installation manual before use and operate the product correctly.
- Please consult a Panasonic agent regarding product installation.
- These products are for indoor use only, do not use them outdoors.
- Please don't use these products for unintended purpose. Doing so could cause an accident.
- Please take measures to prevent falls.
- Do not use the products to store volatile or flammable substances such as benzene or alcohol cylinders. Doing so could cause an accident.

HP SERIES COMMERCIAL FREEZER (COLD-TABLE TYPE)



Pillarless Design

- Smooth in & out
- Effective utilisation of full space
- Large items can be stored easily

Standard Equipped Forced Evaporation System

All Single Phase 220-240V
Model (Easy Installation)

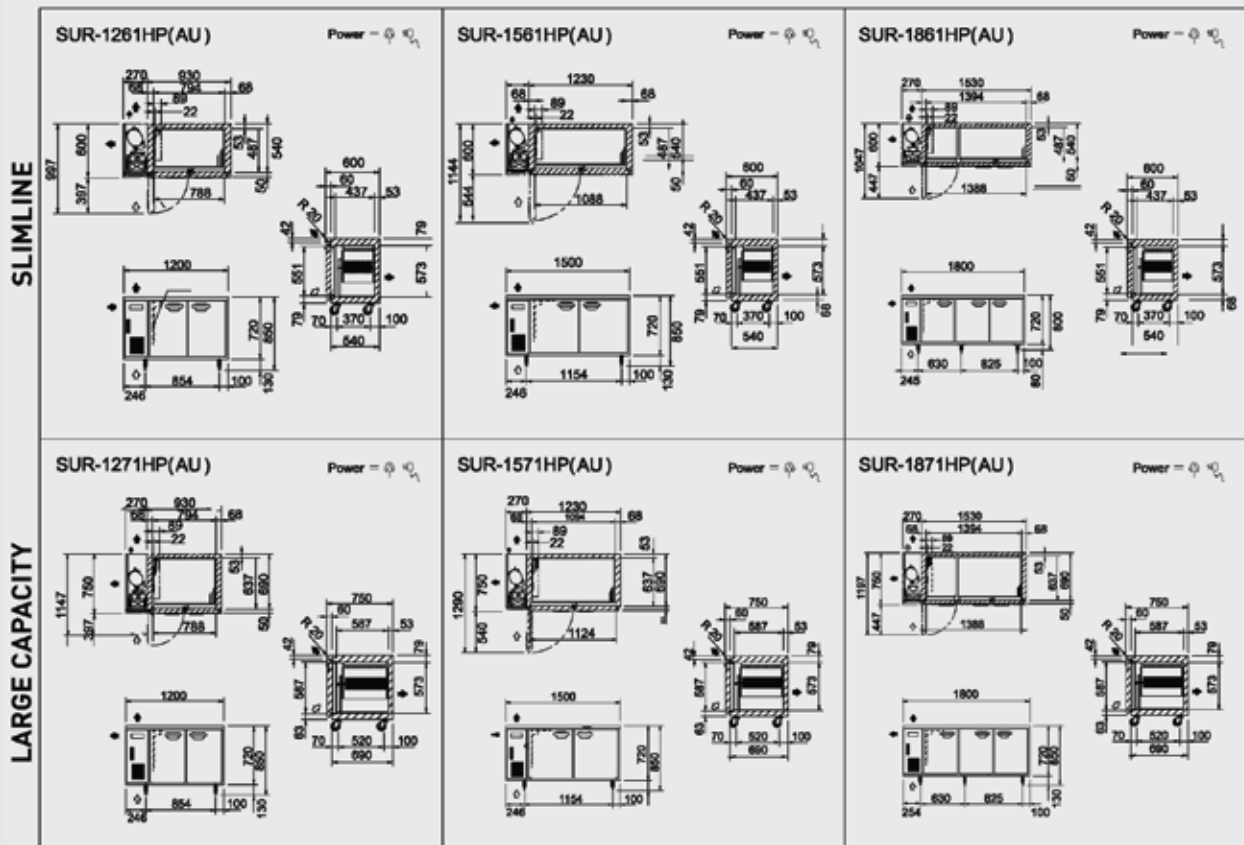

All four of our products in this category are designed for commercial use.

- All four of our products in this category are designed for commercial use.
- Please consult the operation & installation manual before use and operate the product correctly.
- Please consult a Panasonic agent regarding product installation.
- These products are for indoor use only, do not use them outdoors.
- Please don't use these products for unintended purpose. Doing so could cause an accident.
- Please take measures to prevent falls.
- Do not use the products to store volatile or flammable substances such as benzene or alcohol cylinders. Doing so could cause an accident.

Commercial Freezers

HP SERIES UPRIGHT & UNDERBENCH

Tested in 43 °C Environment

Single Phase
(Easy Installation)



Pillarless Design

- Effective utilisation of full space
- Large items can be stored easily

**Smaller Size but
Larger Capacity**

**Standard Equipped Forced
Evaporation System**

**Various Width on
Single Door Split and
2 Door Split**



Upright Commercial Freezer



Centre-Pillarless Design



Forced Evaporation



220-240V/50HZ Single Phase



Heater Defrost



Castors Standard (Legs Optional)



2 Year Parts & Labour Warranty



Product Lockable

SINGLE SPLIT DOOR

SRF-681HP(AUH)

DIMENSIONS	CAPACITY	WEIGHT
W620 x D800 x H1995mm*	483L	110kg

SINGLE SPLIT DOOR

SRF-781HP(AUH)

DIMENSIONS	CAPACITY	WEIGHT
W745 x D800 x H1995mm*	610L	115kg



2 DOOR SPLIT DOOR

SRF-1281HP(AUH)

DIMENSIONS	CAPACITY	WEIGHT
W1210 x D800 x H1995mm*	1080L	165kg

2 DOOR SPLIT DOOR

SRF-1581HP(AUH)

DIMENSIONS	CAPACITY	WEIGHT
W1460 x D800 x H1995mm*	1329L	185kg



3 DOOR SPLIT DOOR

SRF-1881HP(AUH)

DIMENSIONS	CAPACITY	WEIGHT
W1800 x D800 x H1995mm*	1669L	205kg



* Heights shown are with Castors.

HP SERIES COMMERCIAL FREEZER (UPRIGHT TYPE)

Pillarless Design

- Smooth in & out
- Effective utilisation of full space
- Large items can be stored easily

Standard Equipped Forced Evaporation System

All Single Phase 220-240V Model (Easy Installation)

Various Width on Single Door Split and 2 Door Split

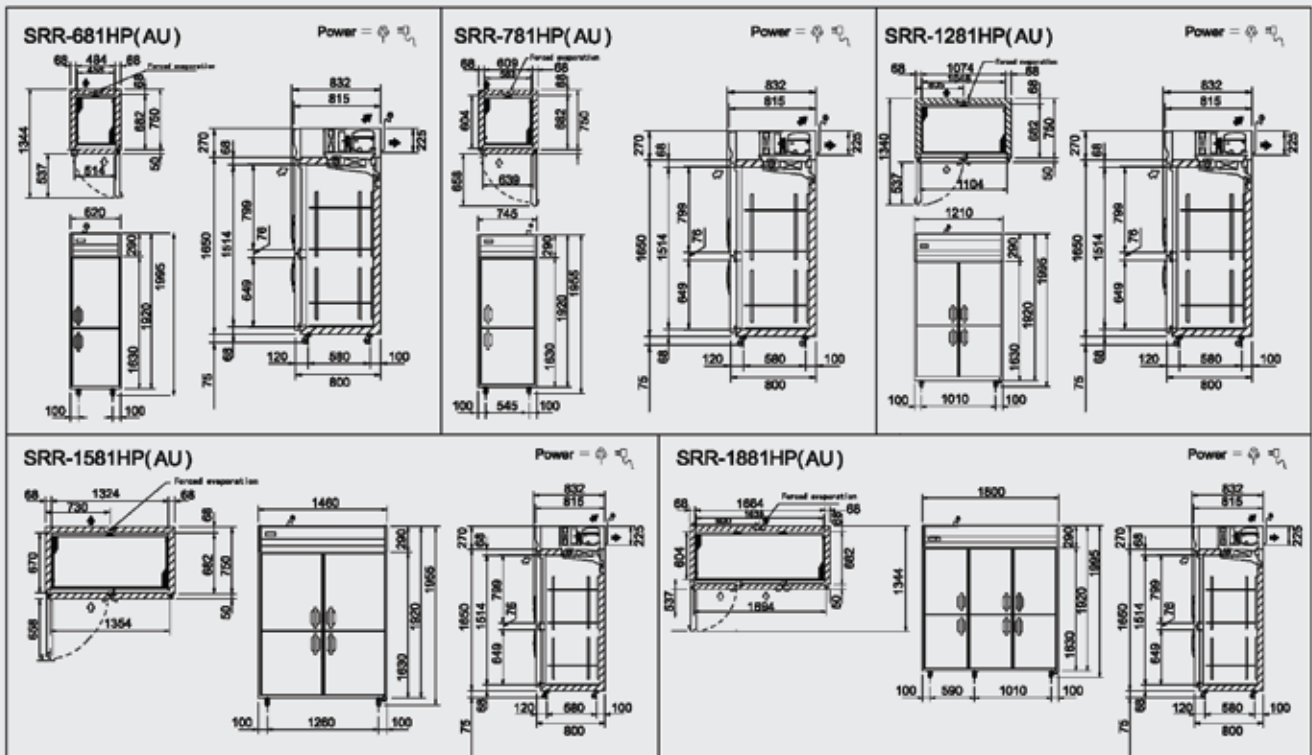

All four of our products in this category are designed for commercial use.

- Please consult the operation & installation manual before use and operate the product correctly.
- Please consult a Panasonic agent regarding product installation.
- These products are for indoor use only, do not use them outdoors.
- Please don't use these products for unintended purpose. Doing so could cause an accident.
- Please take measures to prevent falls.
- Do not use the products to store volatile or flammable substances such as benzene or alcohol cylinders. Doing so could cause an accident.

Underbench Commercial Freezers



Centre-Pillarless Design



Forced Evaporation



220-240V/50HZ Single Phase



Heater Defrost



Castors Standard (Legs Optional)



2 Year Parts & Labour Warranty



Product Lockable



LED Lighting

2 DOOR TYPE

SUF-1271HP(AUH)

DIMENSIONS	CAPACITY	WEIGHT
W1200 x D750 x H850mm*	280L	84kg



2 DOOR TYPE

SUF-1571HP(AUH)

DIMENSIONS	CAPACITY	WEIGHT
W1500 x D750 x H850mm*	393L	105kg



3 DOOR TYPE

SUF-1871HP(AUH)

DIMENSIONS	CAPACITY	WEIGHT
W1800 x D600 x H850mm*	495L	120kg



* Heights shown are with Castors.

HP SERIES COMMERCIAL FREEZER (COLD-TABLE TYPE)

Pillarless Design

- Smooth in & out
- Effective utilisation of full space
- Large items can be stored easily

Standard Equipped Forced Evaporation System

All Single Phase 220-240V Model (Easy Installation)

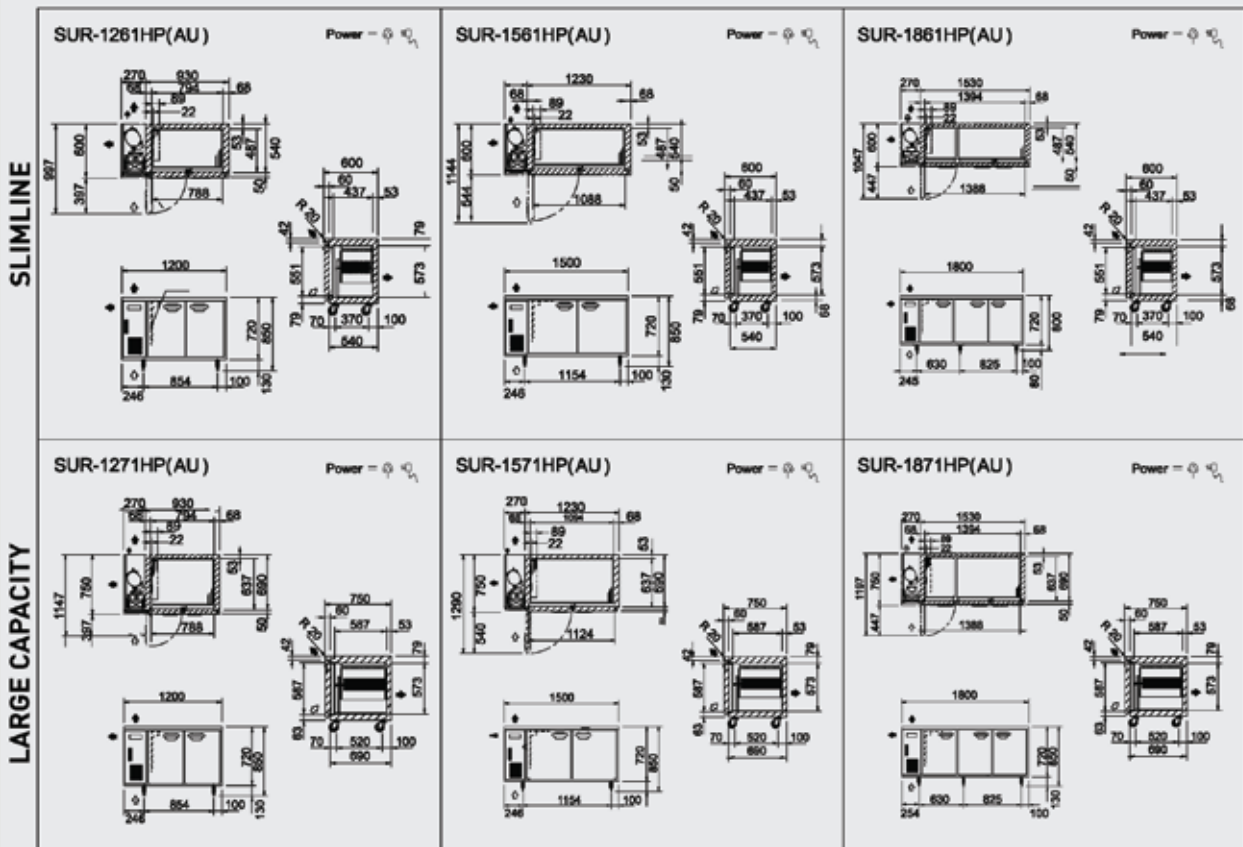

All four of our products in this category are designed for commercial use.

- All four of our products in this category are designed for commercial use.
- Please consult the operation & installation manual before use and operate the product correctly.
- Please consult a Panasonic agent regarding product installation.
- These products are for indoor use only, do not use them outdoors.
- Please don't use these products for unintended purpose. Doing so could cause an accident.
- Please take measures to prevent falls.
- Do not use the products to store volatile or flammable substances such as benzene or alcohol cylinders. Doing so could cause an accident.

Microwaves

Manufacturer of
Both Magnetron &
Microwaves for
Quality Control

Range of Light,
Medium & Heavy
Duty Options



Stackable
& Compact



Extensive
Quality
Control Testing

Internationally used
across the Food Service Sector



INVERTER

Microwave Ovens

Microwaves for reheating and defrosting



**LIGHT DUTY
CONSUMER PRODUCT**

NN-SF574S
FOOD COURTS • CAFÉS

UP TO 15 TIMES PER DAY



MEDIUM DUTY

NE-1037
RESTAURANTS • HOTELS • CLUBS
LARGE CAFÉS • BISTROS

UP TO 100 TIMES PER DAY



HEAVY DUTY

NE-1878 & NE-1853
QSR • CATERING GROUPS
LARGE KITCHENS

100 to 200 TIMES PER DAY

Microwaves for fast cooking and grilling



NE-C1275

**COOKS FROZEN PIZZA
IN 10 MIN**



NE-SCV2

**COOKS FROZEN PIZZA
IN 2.5 MIN**

NE-C1275 & NE-SCV2
MICROWAVE | GRILL | BAKE
CAFES • BISTROS • RESTAURANTS

The ideal solution to cook, toast, bake, grill and reheat a wide range of fresh or frozen foods, such as toasted sandwiches, pastries or pizza, in fact anything needing a crisped, browned finish.

Microwaves with inverter technology -discover the difference

INVERTER V/S CONVENTIONAL MICROWAVES

Conventional microwaves repeatedly turn power on and off in order to maintain the power level. As a result, the food heats or defrosts unevenly or is even overcooked. Inverter microwaves, by contrast vary the power level leading to optimal cooking and defrosting results.

INVERTER MICROWAVES CAN USE UP TO 6.3% LESS ENERGY

With Inverter microwaves, because the power output actually varies, you can save up to 6.3% on energy consumption*, which is good for the environment and great for your wallet.

* Compared to NE-1853 (2650W Inverter microwave compared to 2830W LC type microwave). Excludes NN-SF574

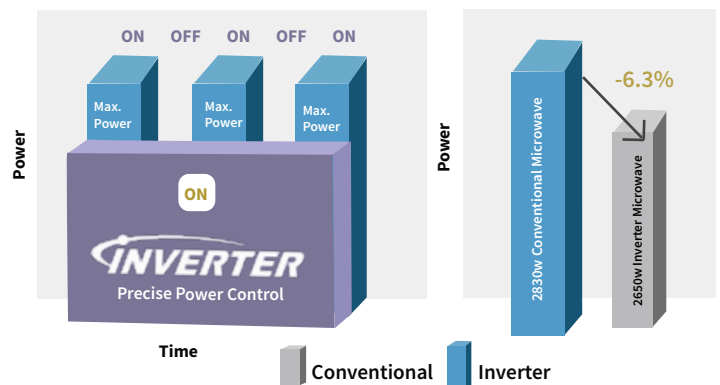

Microwave Oven - Light duty



FLATBED INVERTER MICROWAVE

NN-SF574S

EXTERNAL DIMENSIONS W529 x H326 x D422mm	CAVITY DIMENSIONS W529 x H326 x D422mm
1000W MICROWAVE	CAPACITY 27L

COMMERCIAL WARRANTY: 6 months



Key Features

Flatbed Technology

Panasonic's Flatbed technology with no turntable, provides 31% more cooking area than a conventional turntable model and is supersimple to clean up microwave messes. Plus you can also utilise the whole surface space meaning rectangular dishes will fit with ease.

Inverter Technology With Precise Power Control

Softening hard food such as ice cream, chocolate and cheese proves easy with the dedicated 'melt & soften' function.

SIMPLE, MODERN DESIGN

Featuring a stainless steel panel and frameless design the NN-SF574 integrates into any kitchen.

16 MENU OPTIONS

With 16 Pre-programmed menu options, the microwave will do the thinking for you and determine the time and power settings required- so all you need to do is press 'start'.

Technical Specifications

Inverter	Yes
Outside Dimensions D422 mm	Approx. W529 x H326 x
Oven Cavity Dimensions xH230 x D338 mm	Approx. W354
Cavity Volume	27 L
Microwave Power	1,000W
Net Weight	Approx. 11.7 kg

Microwave Oven - Medium Duty

MEDIUM DUTY MICROWAVE

NE-1037

EXTERNAL DIMENSIONS W510 x D360 x H306mm	CAVITY DIMENSIONS W330 x D330 x H205mm	
1000W MICROWAVE	CAPACITY 22L	WEIGHT 18.6kg



COMMERCIAL WARRANTY: 1 Year On-site

Key Features

- Side Open
- Programmable Memory Pads
- 3 Power Levels
- 3 Stage Cooking
- x2 Double Quantity Pad
- 10 Preset Menu Programs
- Programmable Lock
- Stainless Steel Cabinet & Cavity
- Increase Durability Door Hinge
- Flat Cavity
- Space Saving with Only 360mm Depth

Technical Specifications

Output Power	1000W
Power Source	240V, 50Hz Single Phase
Plug Type	10amp
Required Power	6.6A 1490W
Material	Face of Door/Base Stainless Steel
	Cabinet Stainless Steel
	Cavity Stainless Steel
	Base plate Sealed-in ceramic
Door Design	Side Open
Program	Power Level 3 Levels
	Memory 10 programs
	Stage Cooking 3 stages
	Memory lock Yes
	Multiple quantity keys Yes (X2 for 2 dishes)



Microwave Oven - Heavy Duty Inverter

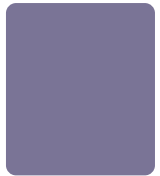

ALL METAL DOOR INVERTER MICROWAVE NE-1878

EXTERNAL DIMENSIONS W422 x D476 x H337mm	CAVITY DIMENSIONS W330 x D310 x H175mm	
1800W MICROWAVE	CAPACITY 18L	WEIGHT 17.5kg

COMMERCIAL WARRANTY: 2 Year On-site

Key Features

Full Metal Door

Full metal door design with no inner door film means it is ideal for easy cleaning and longer lifespan.

Splatter Shield Detection

Automatically stops the unit when the ceiling plate is not in place, preventing damage to the cavity (comes with two shields).

Even Heating

You can cook, reheat or defrost your food without creating cold spots or overcooking edges

Energy Saving

Saves up to 6.3% on energy consumption (compared to Panasonic NE-1853)

Feather Light... Almost

Lighter and more portable unit (40% less heavy compared to Panasonic NE-1853).

Compact Design

Thanks to its compact design, the unit is stackable - saving you a valuable space in your kitchen.

Technical Specifications

Power Source	230-240V, 50Hz Single Phase	
Plug Type	15amp	
Required Power	11.6A 2650W	
Material	Face of Door/Base	Stainless Steel
	Cabinet	Stainless Steel
	Cavity	Stainless Steel
	Base plate	Sealed-in ceramic
Door Design	Side Open	
Program	Power Level	10 Levels
	Memory	30 programs
	Stage Cooking	5 stages
	Memory lock	Yes
	Multiple quantity keys	Yes
		(X2 for 2 dishes, X3 for 3 dishes)
Display	LCD	
Oven Lamp	LED	

Microwave Oven - Heavy Duty

HEAVY DUTY MICROWAVE

NE-1853

EXTERNAL DIMENSIONS W422 x D508 x H377mm		CAVITY DIMENSIONS W330 x D3108 x H175mm	
1800W MICROWAVE	CAPACITY 18L	WEIGHT 30kg	

COMMERCIAL WARRANTY: 2 Year On-site



Key Features

- 1800W of Cooking Power
- 2 Magnetrons
- Dual Power Feed for More Consistent, Even Cooking
- Side Open
- Programmable Memory Pads
- 15 power Levels
- 5 Stage Cooking
- Easy Extension Pad +10s/+20s
- 30 Preset Menu Programs
- Programmable Lock
- Easy to Clean Air Filter
- Stainless Steel Cabinet & Cavity
- Removable Ceiling Splatter Shield
- Energy Efficient LED Lighting & LCD Display

Technical Specifications

Power Source	240V, 50Hz Single Phase	
Plug Type	15amp	
Required Power	12.3A 2830W	
Material	Face of Door/Base	Stainless Steel
	Cabinet	Stainless Steel
	Cavity	Stainless Steel
	Base plate	Sealed-in ceramic
Door Design	Side Open	
Program	Power Level	15 Levels
	Memory	30 programs
	Stage Cooking	5 stages
	Memory lock	Yes
	Multiple quantity keys	Yes
		(X2 for 2 dishes, X3 for 3 dishes)
Display	LCD	
Oven Lamp	LED	
Stackable	Yes	

Optional Accessory
Microsave® Liner - NE-CPS2A -
Minimises cleaning time and extends
the microwave's lifespan by providing total
protection for the cavity, roof, sides, back and base.



Microwave oven - Heavy Duty Combination



HEAVY DUTY COMBINATION MICROWAVE NE-C1275

EXTERNAL DIMENSIONS W600 x D484 x H383mm	CAVITY DIMENSIONS W406 x D336 x H217mm	
1150W MICROWAVE 1800W CONVECTION OVEN 1800W GRILL	CAPACITY 29.6L	WEIGHT 41kg



COMMERCIAL WARRANTY: 2 Year On-site

Key Features

- 1800W Convection Oven, 1800W Grill, 1150W Microwave
- High speed Fan Grill and Grill Convection functions for faster browning results
- Combination Options include: Microwave + Grill; Microwave + Convection; Microwave + Fan Grill; and Microwave + Grill Convection
- Preset Combi keys offer 5 popular combination options which can be selected with one touch
- Microwave has 6 power levels. Dual emission bottom energy feed ensures even heating
- Convection oven settings range from 100°C – 250°C
- 4 element Quartz Grill with 2 power levels and recessed elements
- Three fast 'Preheat' settings – up to 240°C on continuous standby (will maintain temperature for up to 4 hours of non use).
- 2 shelf positions
- Up to 99 programs available, each can be preset with up to 3 stages of combination or single cooking cycles
- Programmable manually or via SD Memory Card and your Personal Computer
- Fast cool feature to quickly reduce oven temperature for easy cleaning and low temperature cooking
- Beep tone option and clean air filter reminder
- Program lock

Technical Specifications

Power Source 230-240V / 50Hz, Single phase

Plug Type 15amp

Power Requirement 2900W 12.2A

Power Supply AUS/NZ

Frequency 2450 MHz

Net Weight 41kg (inc accessories)

Cubic Capacity 29.6 litres (1 cu.ft)

Output Power

Microwave 1150w

Grill 1800w

Convection Oven 1800w

MICROWAVE

Power Levels 6

Timer

High, Medium Up to 15 mins

Low, Simmer,

Defrost, Stand Up to 1 hour

CONVECTION OVEN

Temperature Range 100°C – 250°C

Timer Up to 1 hour 40 mins

GRILL

Timer (min) Up to 1 hour

Power Levels 2

Microwave oven - Fast Cook Convection

FAST COOK CONVECTION MICROWAVE

NE-SCV2

EXTERNAL DIMENSIONS W474 x D565 x H412mm	CAVITY DIMENSIONS W270 x D330 x H110mm	
1200W MICROWAVE 1350W CONVECTION OVEN 1800W GRILL	CAPACITY 10L	WEIGHT 38.1kg

COMMERCIAL WARRANTY: 2 Year On-site



Key Features

Multi-function convection cooking

The ideal solution to cook, toast, bake, grill and reheat a wide range of fresh or frozen foods, such as toasted sandwiches, pastries or pizza, in fact anything needing a crisped, browned finish.

Space saving design

Maximum flexibility as it easily fits on a small worktop. Stackable unit allows you to add a second unit without using additional bench space

Efficient performances

Speed convection with twin inverter technology ensures great results with minimum time

Optimum cooking made easy

Panasonic exclusive Twin Inverter technology cooks food evenly with no cold spots, always providing optimum cooking results

Ventless cooking operation

With the built in catalytic converter

Easy to clean cavity

Reduce cleaning times and simplify maintenance thanks to the Ceramic Base Tray

Menu flexibility

The SD Card allows rapid menu changes and updates for up to 999 cooking menu settings. In addition you food images can be loaded onto the control panel to be used as buttons

Technical Specifications

Power Consumption	230-240V, 50HZ, Single Phase, 16amp
Plug Type	20amp
High Frequency Output	1200 to 0W / Switchable in 9 steps
Convection Heater Output	1350W Temperature adjustable 180 to 250°
Grill Heater Output	1800W (2 Step Switchable)
Preheat Adjustment Range	150° C (standby Preheat), 180° C, 250° C
Memory Capacity	10 to 1,000
Weight	Approx 37.4kg
Door Opening Direction	Vertical

Rice Cookers

Uniform Cooking
by Triple Coil

Micro Switch Control
for More Durability



Double Thermal Fuse
for Superior Safety

Product Compliant to
Australian Standards



Commercial Rice Cookers

23 CUP RICE COOKER

SR-GA421F



DIMENSIONS	CAPACITY	WARRANTY
W367 x D424 x H289mm	4.2L	1 Year



Triple Coil for Uniform Cooking



Micro Switch Control for More Durability*



Double Thermal Fuse For Superior Safety



Stainless Steel Lid



Cooks Any Style of Rice

30 CUP RICE COOKER

SR-GA541F



DIMENSIONS	CAPACITY	WARRANTY
W466 x D558 x H338mm	5.4L	1 Year

40 CUP RICE COOKER

SR-GA721F



DIMENSIONS	CAPACITY	WARRANTY
W466 x D558 x H366mm	7.2L	1 Year

Replacement bowls available

Technical Specifications

Model number	SR-GA721F	SR-GA541F	SR-GA421F
Power	240V / 15A	240V/ 10A	240V/ 10A
Pans	Non-stick pan	Non-stick pan	Non-stick pan
Rice cooking	Yes	Yes	Yes
Keep warm up to	5hr	5hr	5hr
Weight	15.0kg	13.5kg	6.4kg

Commercial Rice Cookers



20 CUP RICE COOKER
SR-UH36

DIMENSIONS	CAPACITY	WARRANTY
W428 x D384 x H347mm	3.6L	1 Year

Replacement bowls available

- Scoop Holder
- Steam Vent
- Dew Collector
- Side, bottom & Top Heater
- Side Heater

Key Features

- Hinged lid with silicone seal
- 360° Double keep warm function
- 12 Hours keep warm technology enables rice cooking neither overcooked nor undercooked
- Triple Micro switch for Safety
- Glass wool insulation
- Anodised aluminium pan
- Stainless steel lid
- 1400W
- Cooks up to 2kg of rice

Technical Specifications

Model number	SR-UH36
Power Source	230V/10A
Power Consumption	1400W
Pan Thickness	1.95mm
Rice cooking	Yes
Keep warm	12hr
Weight	8.2kg

Rent or Buy

Flexible short and long term
Rental options available



Hussmann Rental

Scan the code to learn more about our rental options

Application Process

- Contact for a quote – Phone **1300 740 805** or email **Rental@hussmann.com**
- Agreement forms completed
- Hussmann arranges delivery of the cases (Tested and Tagged prior to delivery)
- Invoiced monthly unless arranged prior
- We will contact you prior to collection to confirm pick up date or rental extension.

www.hussmann.com.au

Email: Rental@hussmann.com

Ph: 1300 740 805

Contact Details

Husmann Australia Pty. Ltd.

Address

66 Glendenning Road,
Glendenning, NSW 2761

Phone

02 8805 0400

Website

www.husmann.com.au

Customer Service

Panasonic@husmann.com

Warranty

warranty.aus@husmann.com

Spare Parts

spares_aus@husmann.com

McAlpine Hussman Ltd. New Zealand

Address

2-6 Niall Burgess Road
Mt Wellington, Auckland 1060

Phone

0800 473 374

Website

www.mcalpinehusmann.co.nz

