



User Guide

Quality, Design and Innovation



home.liebherr.com/fridge-manuals









LIEBHERR

Contents

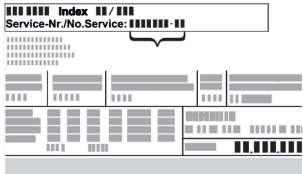
1	Appliance at a glance.....	3	6	Features.....	32
1.1	Scope of supply.....	3	6.1	Safety lock.....	32
1.2	Overview of appliance and equipment.....	3	6.2	Sensors.....	33
1.3	Special features.....	3	6.3	Interfaces.....	33
1.4	Range of use of appliance.....	3	7	Maintenance.....	33
1.5	Appliance noise emissions.....	4	7.1	Maintenance schedule.....	33
1.6	Compliance.....	4	7.2	Defrosting appliance.....	34
1.7	SVHC substances according to REACH regulation.....	4	7.3	Cleaning the appliance.....	34
2	General safety instructions.....	4	8	Customer help.....	35
3	Putting into operation.....	6	8.1	Technical specifications.....	35
3.1	Installation conditions.....	6	8.2	Technical fault.....	36
3.2	Appliance dimensions.....	6	8.3	Customer Service.....	36
3.3	Transporting appliance.....	7	8.4	Type plate.....	37
3.4	Unpacking appliance.....	7	9	Shutting down.....	37
3.5	Removing transport lock.....	7	10	Disposal.....	37
3.6	Installing door handle.....	7	10.1	Preparing appliance for disposal.....	37
3.7	Mounting anti-tipping device.....	7	10.2	Disposing of the appliance in an environmentally friendly manner.....	37
3.8	Installing appliance.....	8	11	Additional information.....	37
3.9	Setting up the appliance so it is level.....	8	12	Quick Start Guide for everyday use.....	39
3.10	Installing multiple appliances.....	8			
3.11	After installation.....	8			
3.12	Disposing of packaging.....	9			
3.13	Reversing the door opening direction.....	9			
3.14	Aligning the door.....	16			
3.15	Connecting appliance.....	16			
3.16	Switching on appliance (first use).....	17			
4	Storage.....	17			
4.1	Information regarding storage.....	17			
4.2	Storage times.....	17			
5	Controls.....	17			
5.1	Control and display elements.....	17			
5.1.1	Status display.....	17			
5.1.2	Display symbols.....	17			
5.1.3	Acoustic signals.....	18			
5.2	Navigation.....	18			
5.2.1	Navigating using buttons.....	18			
5.2.2	Settings menu.....	18			
5.2.3	Customer menu.....	19			
5.2.4	Setting values.....	19			
5.2.5	General rules.....	19			
5.3	Functions.....	19			
5.3.1	Overview of functions.....	19			
5.3.2	Switching appliance on and off	20			
5.3.3	Temperature	20			
5.3.4	Temperature recording	20			
5.3.5	Settings menu access protection	21			
5.3.6	Access code.....	21			
5.3.7	Maintenance interval reminder	22			
5.3.8	Language	23			
5.3.9	Temperature unit	23			
5.3.10	Display brightness	23			
5.3.11	Alarm Sound.....	23			
5.3.12	Key Sound.....	24			
5.3.13	WiFi connection	24			
5.3.14	LAN connection	25			
5.3.15	Info.....	26			
5.3.16	Operating hours	26			
5.3.17	Software.....	26			
5.3.18	Sensor calibration	26			
5.3.19	Temperature alarm	26			
5.3.20	Door alarm	27			
5.3.21	Alarm simulation	28			
5.3.22	Alarm relay	28			
5.3.23	DemoMode.....	29			
5.3.24	Factory reset	29			
5.4	Messages.....	30			
5.4.1	Warnings.....	30			
5.4.2	Reminder.....	32			

The manufacturer is continually working on the further development of all types and models. Please be aware that we reserve the right to make changes to the shape, equipment and technology.

Symbol	Explanation
	Read instructions Please read the information in these instructions carefully to understand all of the benefits of your new appliance.
	Full instructions on the internet You can find detailed instructions on the internet using the QR code on the front of these instruction or by entering the service number at home.liebherr.com/fridge-manuals . The service number can be found on the serial tag:  <i>Fig. Example illustration</i>
	Check appliance Check all parts for transport damage. If you have any complaints, please contact your agent or customer service.
	Differences These instructions apply to a range of models, so differences are possible. Sections that apply to certain models only are marked with an asterisk (*).
	Instructions and results Instructions are marked with a ▶. Results are marked with a ▷.
	Videos Videos about the appliances are available on the YouTube channels of Liebherr-Hausgeräte.

These operating instructions apply to:

- SFFfg 4001
- SFFfg 5501

1 Appliance at a glance

1.1 Scope of supply

Check all parts for transport damage. If you have any complaints, please contact your dealer or Customer Service. (see 8.3 Customer Service)

The delivery comprises the following parts:

- Free-standing appliance
- Equipment *
- Installation materials *
- Operating instructions
- Service brochure
- Quality certificate *
- Mains cable
- Handle incl. screws and Torx wrench
- Wall fastening kit

1.2 Overview of appliance and equipment

SFFfg 4001
SFFfg 5501

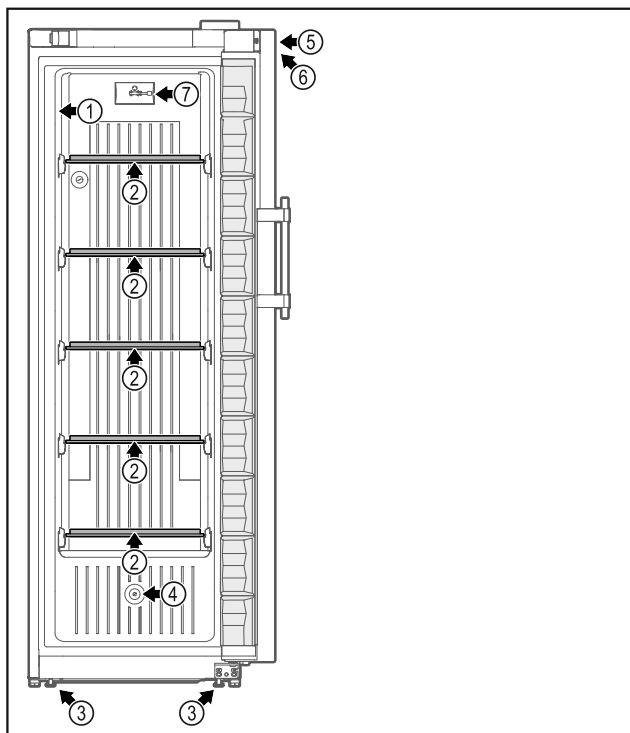

Fig. 1 Example illustration of the front

Equipment

- | | |
|--------------------------------|--|
| (1) Type plate | (5) Lock |
| (2) Glass shelf | (6) Control elements and temperature display |
| (3) Adjusting feet / castors * | (7) C sensor |
| (4) Sensor feedthrough | |

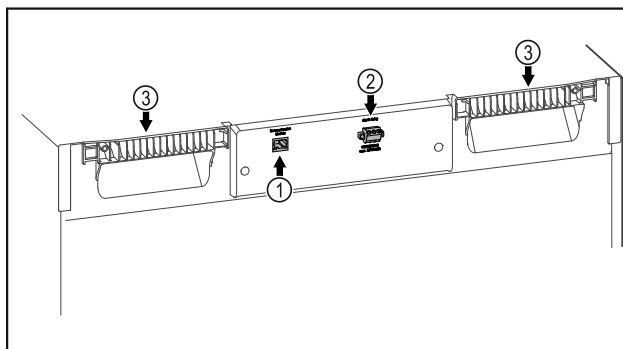

Fig. 2 Example illustration of the rear

Equipment

- | | |
|---------------------------------|------------------|
| (1) LAN/WiFi interface * | (3) Carrying aid |
| (2) Potential-free alarm output | |

1.3 Special features

Note

Accessories are available from Customer Service (see 8.3 Customer Service) and the Liebherr-Hausgeräte store at home.liebherr.com/shop/de/deu/zubehor.html.

SmartModule

The appliance can be fitted with a SmartModule.

This is a WiFi and LAN interface for the connection between the appliance and an external documentation and alarm system such as Liebherr SmartMonitoring.

Retrofitting drawers

Temperature qualification is required when retrofitting drawer systems in Liebherr refrigerators/freezers where these are used for temperature-sensitive materials such as chilled drugs and refrigerated products which are subject to specific standards requirements. Retrofitting drawers in Liebherr refrigerators/freezers can result in the goods stored becoming spoiled or damaged. The retrofitting must therefore be completed exclusively by authorised service providers from the manufacturer of the refrigerator/freezer.

1.4 Range of use of appliance

Intended use

This laboratory freezer, with an interior free of ignition sources, is suitable for professional storage of highly flammable products in closed containers, at temperatures between -9 °C and -30 °C.

Explosion-proof interior

The values relating to your appliance are printed on the sticker on the appliance door.



Fig. 3 Protection category: II 3/-G Ex ec IIC T6 Gc/-

General safety instructions

The interior is certified as an area subject to explosion hazards as per 2014/34/EU (ATEX Directive). Typical products to be stored include research samples, reagents, laboratory inventory etc., that are categorised into the appropriate zone, explosion group, and temperature class.

Refer to the safety data sheet for details of the explosion group of the products to be stored. Contact the supplier of the respective product if there is any uncertainty.

It is necessary to use an independent alarm system with permanent monitoring if storing valuable or temperature-sensitive substances or products. This alarm system must be designed in such a way that every alarm state is immediately registered by a competent person who then takes appropriate measures.

Foreseeable incorrect use

Do not use the appliance for the following applications:

- Storage and refrigeration of:
 - Chemically unstable substances
 - Blood, plasma or other body fluids for the purpose of infusion, application or introduction in the human body.
- Use in potentially explosive atmospheres.
- Use outdoors or in areas exposed to dampness and splashing water.

Improper use of the appliances will result in goods stored being damaged or spoiled.

Climate classes

The applicable climate class for your appliance is printed on the type plate.

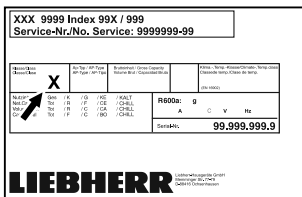

Fig. 4 Type plate

(X) The climate class states the ambient conditions in which the appliance can be operated safely.

Climate class (X)	max. room temperature	max. rel. humidity
7	35 °C	75%

Note

The minimum permitted room temperature at the setup location is 10 °C.

1.5 Appliance noise emissions

The A-weighted emission sound pressure level during operation of the appliance is under 70 dB(A) (sound power rel. 1 µW).

1.6 Compliance

The refrigerant circuit has been tested for leaks.

This appliance complies with the applicable safety regulations and with EU directives 2014/35/EU, 2014/30/EU, 2014/34/EU and 2011/65/EU.

The full text of the EU Declaration of Conformity is available on the following website: www.liebherr.com

1.7 SVHC substances according to REACH regulation

You can check whether your appliance contains SVHC substances according to REACH regulation at the following link: home.liebherr.com/de/deu/de/liebherr-erleben/nachhaltigkeit/umwelt/scip/scip.html

2 General safety instructions

Please keep these operating instructions in a safe place so you can refer back to them at any time.

If you pass the appliance on, please hand these operating instructions to the next user.

Read these operating instructions carefully before use to ensure safe and correct use of the appliance. Follow the instructions, safety instructions and warning messages included at all times. They are important for ensuring you can operate and install the appliance safely and without any problems.

Danger for the user:

- This appliance may only be used by specialist and laboratory personnel who have been trained for this purpose and are familiar with all safety measures pertaining to laboratory work. Children and persons with reduced physical, sensory or mental capabilities or lack of experience and knowledge must not commission or operate this appliance.
- The socket must be easily accessible so that the appliance can be disconnected quickly from the electricity supply in an emergency. It must not be located in the area behind the appliance.
- When disconnecting the appliance from the supply, always take hold of the plug. Do not pull the cable.
- In the event of a fault pull out the mains plug or deactivate the fuse.

- **WARNING:** Do not damage the mains power cable. Do not operate the appliance with a defective mains power cable.
- **WARNING:** Multiple sockets/distributors and other electronic equipment (such as halogen transformers) must not be placed or operated at the rear of the appliance.
- **WARNING:** Keep ventilation openings, in the appliance enclosure or in the built-in structure, clear of obstruction.
- **WARNING:** Dust deposits on fan blades! Risk of sparking due to friction! Do not store dusty objects in the appliance. The ventilation slots of the recirculation fan must be cleaned each month using a vacuum cleaner.
- Only customer service or other specially trained staff may repair or perform other operations on the appliance.
- Only assemble, connect and dispose of the appliance according to the instructions.

Fire hazard

- The coolant used (information on the model plate) is ecofriendly but also flammable. Any leaking coolant may ignite.
 - **WARNING:** Do not damage refrigeration circuit.
 - Do not handle ignition sources inside the appliance.
 - **WARNING:** Do not use electrical appliances in the fridge compartment which do not comply with the design recommended by the manufacturer.
 - If the refrigerant leaks: remove any naked flames or ignition sources from the vicinity of the leakage point. Properly air the room. Inform customer services.
- Do not operate the appliance close to explosive gases.
- Do not store or use petrol or other flammable gases and liquids close to the appliance.
- Keep burning candles, lamps and other items with naked flames away from the appliance so that they do not set the appliance on fire.

Danger of tipping and falling:

- **WARNING:** In order to prevent danger due to an unstable appliance, it must be fixed in accordance with the instructions.
- Do not misuse the plinth, drawers, doors etc. as a step or for support.

Danger of frostbite, numbness and pain:

- Avoid prolonged skin contact with cold surfaces or refrigerated/frozen goods or take protective measures, e.g. wear gloves.

Danger of injury and damage:

- **WARNING:** Do not use mechanical equipment or other methods to speed up the defrosting process other than those recommended by the manufacturer.
- **WARNING:** Risk of injury due to electric shock! There are live electrical parts under the cover.
- **NOTICE:** Appliance must only be used using original manufacturer accessories or using accessories from other providers approved by the manufacturer. The user bears the risk of using accessories which are not approved.

Risk of crushing

- Do not hold the hinge when opening and closing the door. Fingers may get caught.

Specialist personnel qualifications:

The appliance may only be installed, tested, maintained, and commissioned by specialist personnel who are familiar with the installation, commissioning, and operation of the appliance.

Specialist personnel are persons who, on account of their specialist training, knowledge and experience as well as their knowledge of the relevant standards, are able to assess and perform the work assigned to them and identify potential hazards. They must have training, instruction, and authorisation to work on the appliance.

Symbols on the appliance:



This symbol may be located on the compressor. It relates to the oil in the compressor and makes reference to the risk that: **Swallowing or inhaling can be fatal.** This advice is only relevant to recycling. There is no danger in normal operation.



WARNING: Danger of fire / flammable materials. This symbol is located on the compressor and indicates the danger of flammable materials. Do not remove the sticker.

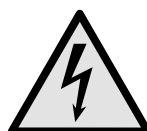

The symbol is located on the back of the appliance near the alarm relay and indicates the following danger: **Electric shock!** Even if an appliance is disconnected from the mains there may still be extraneous voltage. Do not remove sticker.

Putting into operation



This or a similar sticker may be located on the rear of the appliance. This sticker indicates that there are vacuum insulation panels (VIP) or perlite panels in the door and/or housing. This advice is only relevant to recycling. Do not remove the sticker.

Please note the warning messages and other specific advice in the other chapters:

	DANGER	Indicates an immediately hazardous situation which will lead to death or serious injuries if it is not avoided.
	WARNING	Indicates a hazardous situation which will lead to death or serious injuries if it is not avoided.
	CAUTION	Indicates a hazardous situation which will lead to minor or moderate injuries if it is not avoided.
	NOTICE	Indicates a hazardous situation which may lead to damage to property if it is not avoided.
	Note	Indicates useful instructions and tips.

3 Putting into operation

3.1 Installation conditions



WARNING

Fire hazard due to dampness!
If live parts or the mains lead become damp this may cause short circuits.

- ▶ The appliance is designed for use in enclosed areas. Do not operate the appliance outdoors or in areas where it is exposed to splash water or damp conditions.

3.1.1 Installation location



WARNING

Leaking coolant and oil!
Fire. The coolant contained in the appliance is eco-friendly, but also flammable. The oil contained in the appliance is flammable. Escaping coolant and oil can ignite if the concentration is high enough and in contact with an external heat source.

- ▶ Do not damage the pipelines of the coolant circuit and the compressor.

- Do not install appliance in direct sunlight, next to an oven, radiator or similar.
- The best place for installation is a dry and well ventilated room.
- If the appliance is installed in a very humid environment, condensation can form on the outside of the appliance. Always ensure good airflow and ventilation in the installation location.

- The more refrigerant there is in the appliance, the larger the space it is installed in must be. If the space is too small, any leak may create a flammable mixture of gas and air. For every 8 g of refrigerant, the installation space must be at least 1 m³. Information regarding the refrigerant can be found on the type plate inside the appliance.
- The floor of the location must be horizontal and even.
- The installation location must be able to withstand the weight of the appliance plus weight when stocked to maximum level. (see 8.1 Technical specifications)

3.1.2 Electrical connection



WARNING

Danger of fire due to incorrect positioning!
If the mains cable or plug touches the back of the appliance, the vibration can damage the mains cable or the plug resulting in a short circuit.

- ▶ Make sure the mains cable is not trapped under the appliance when you position the appliance.
- ▶ Stand the appliance so that it is not touched by connectors or main cables.
- ▶ Do not connect any appliances to sockets in the area of the back of the appliance.
- ▶ Do **not** place and operate multi-sockets/power distributors and other electronic devices (such as halogen transformers) at the back of the appliances.

3.2 Appliance dimensions

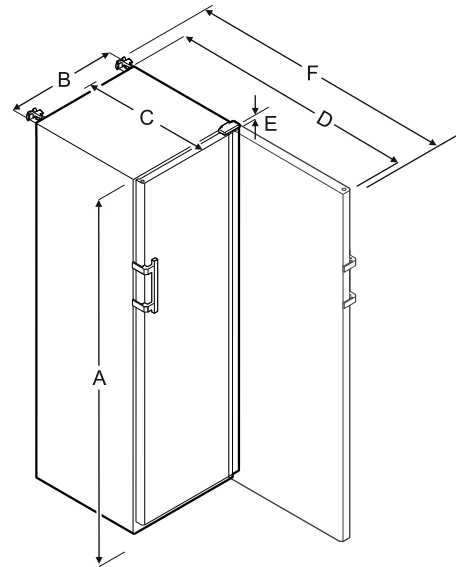

	SFFfg 4001	SFFfg 5501
A	1884 mm	1684 mm
B	597 mm	747 mm
C	664 mm	779 mm
D	1203 mm	1468 mm
E	23 mm	23 mm
F	1241 mm	1506 mm

- A** = appliance height including feet/castors
- B** = appliance width without handle [handle depth = 45 mm]
- C** = appliance depth without handle [handle depth = 45 mm]
- D** = appliance depth with door open
- E** = hinge height

F = appliance depth with protruding handle and anti-tipping device

3.3 Transporting appliance

- ▶ On initial setup: Transport the appliance in its packaging.
- ▶ When transporting after initial setup (e.g. relocation): Transport the appliance unloaded.
- ▶ Transport the appliance upright.
- ▶ Use two people to transport the appliance.

3.4 Unpacking appliance

- ▶ Check the appliance and the packaging for damage during transport. Contact the supplier immediately if you suspect any damage. Do not connect appliance to the power supply.
- ▶ Remove all materials from the back or the side walls of the appliance that may prevent proper installation or prevent air flow and ventilation.

3.5 Removing transport lock

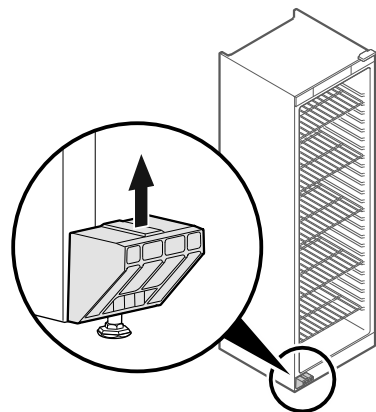

Fig. 5

- ▶ Remove transport lock in upwards direction.
- ▷ Base holder remains on the appliance.

3.6 Installing door handle

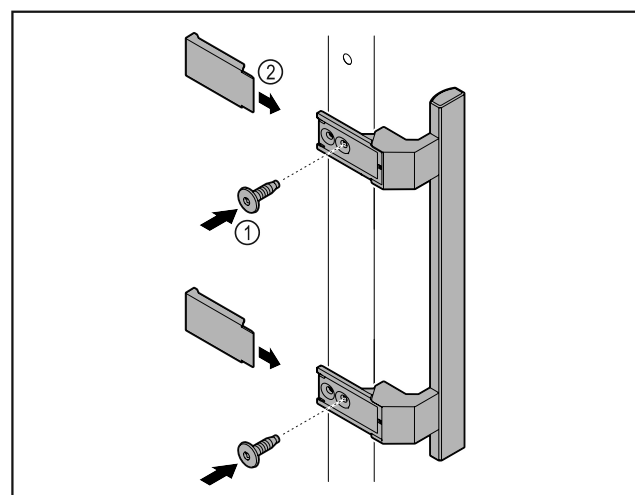

Fig. 6

- ▶ Attach handle from accessory kit to the door using the screws Fig. 6 (1) supplied.
- ▶ Put on covers Fig. 6 (2).

3.7 Mounting anti-tipping device

Tools

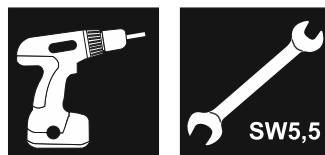

Fig. 7

Prevent appliance from tipping over.

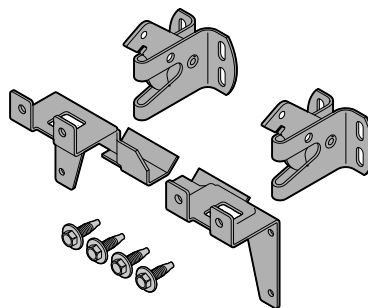

Fig. 8

The anti-tipping device, consisting of two retaining parts, two retaining hooks and four screws (4 x 14), is included with the appliance.

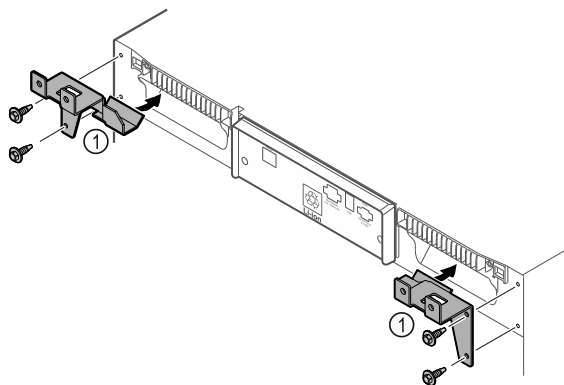

Fig. 9

- ▶ Mount retaining parts Fig. 9 (1) on the appliance using the screws supplied.
- ▶ Push appliance with retaining parts mounted against the wall.

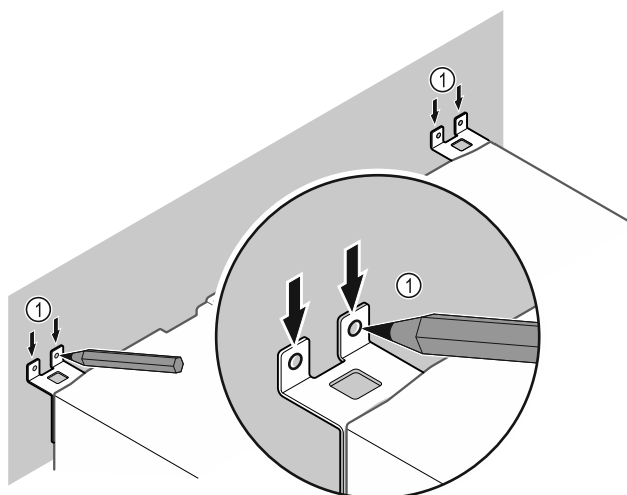

Fig. 10

- ▶ Make markings on the wall Fig. 10 (1).
- ▶ Remove appliance.

Putting into operation

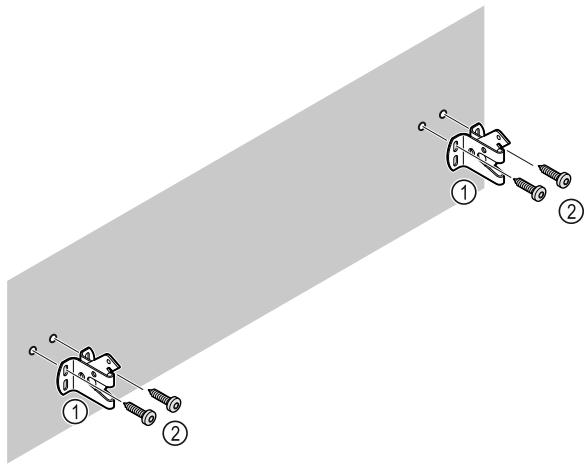

Fig. 11

Use fixing material (e.g. dowels) which is appropriate for the nature of the wall (wood, concrete) and sufficient attachment points .

- ▶ Attach retaining hooks.

3.8 Installing appliance



CAUTION

Risk of injury and damage.

- ▶ Use 2 people to install appliance.



CAUTION

Risk of injury and damage.

The door can knock against the wall and become damaged as a result. In the case of glass doors, the damaged glass can cause injuries.

- ▶ Protect the door from knocking against the wall. Attach door stopper, e.g. felt stopper, to the wall.

- ▶ Connect all necessary components (e.g. mains cable) to the back of the appliance and route to the side.

Note

Cables can be damaged.

- ▶ Do not jam the cable when pushing the appliance back.

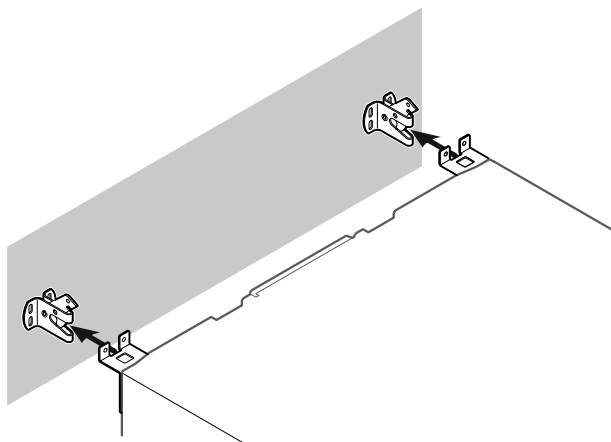

Fig. 12

- ▶ Slide appliance up against the wall so that the retaining parts latch into the securing hooks.
- ▷ The appliance is now secured against tipping.
- ▷ It can be released by folding back the securing hooks.

3.9 Setting up the appliance so it is level

NOTICE

Appliance body is deformed and door does not close.

- ▶ Align appliance horizontally and vertically.
- ▶ Compensate for uneven floors using adjustable feet.



WARNING

Incorrect height adjustment of the adjustable foot!

Can cause severe or even fatal injury. Incorrect height adjustment can cause the bottom part of the adjustable foot to come loose and the appliance to tip over.

- ▶ Do not unscrew the adjustable foot too far.

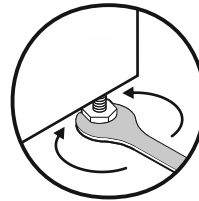

Fig. 13

Raising appliance:

- ▶ Turn adjustable foot clockwise.

Lowering appliance:

- ▶ Turn adjustable foot anticlockwise.

3.10 Installing multiple appliances

NOTICE

Risk of damage due to condensation between the side walls.

- ▶ Do not install the appliance directly next to another fridge.
- ▶ Install appliances with a space 3 cm between appliances.
- ▶ Only install multiple appliances up to temperatures of 35 °C and 65% humidity next to one another.
- ▶ At higher levels of humidity, increase space between appliances.

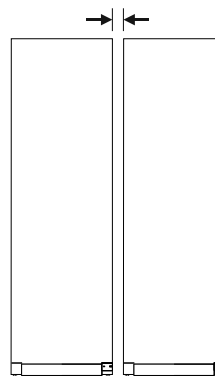

Fig. 14 Side-by-side installation

Note

A side-by-side kit is available as an accessory via Liebherr Customer Service. (see 8.3 Customer Service)

3.11 After installation

- ▶ Take off the protective film from the exterior of the appliance.
- ▶ Clean appliance. (see 7.3 Cleaning the appliance)
- ▶ If necessary: Disinfect the appliance.

- ▶ Keep the invoice so you have the appliance and dealer information available if needed.

3.12 Disposing of packaging



WARNING

Danger of suffocation due to packing material and plastic film!

- ▶ Do not allow children to play with packing material.

The packaging is made of recyclable materials:

- corrugated board/cardboard
- expanded polystyrene parts
- polythene bags and sheets
- polypropylene straps
- nailed wooden frame with polyethylene panel*



- ▶ Take the packaging material to an official collecting point.

3.13 Reversing the door opening direction

Tools

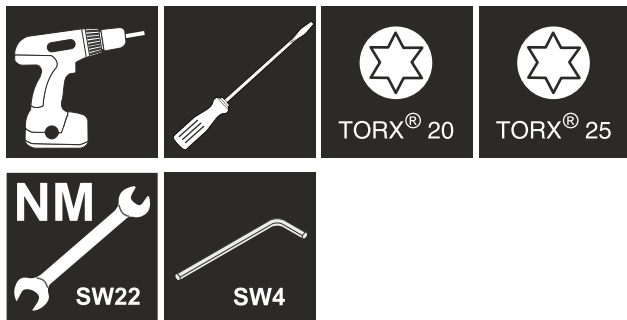

WARNING

Risk of injury if the door is not reversed correctly!

- ▶ The door may only be reversed by qualified personnel.



WARNING

Risk of injury and material damage due to heavy door!

- ▶ Only perform the conversion if you can carry a weight of 25 kg.
- ▶ Always have someone help you carry out the conversion.

NOTICE

Live parts!

Damage to electrical components.

- ▶ Disconnect the power plug before reversing the door.

- ▶ Open the door.

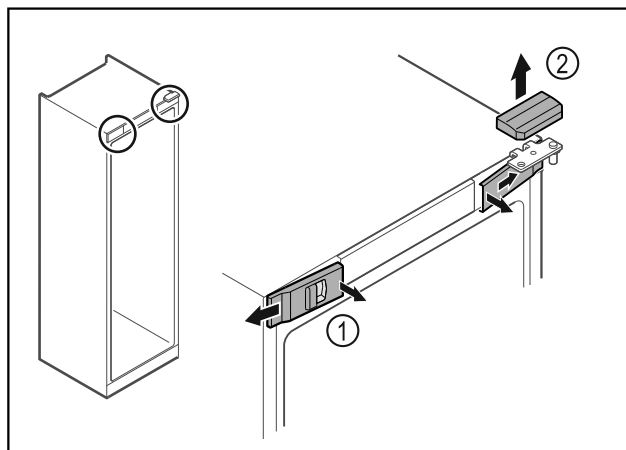

Fig. 15

- ▶ Unlatch the front covers Fig. 15 (1) on the inside and remove them sideways.
- ▶ Lift off the upper cover Fig. 15 (2).

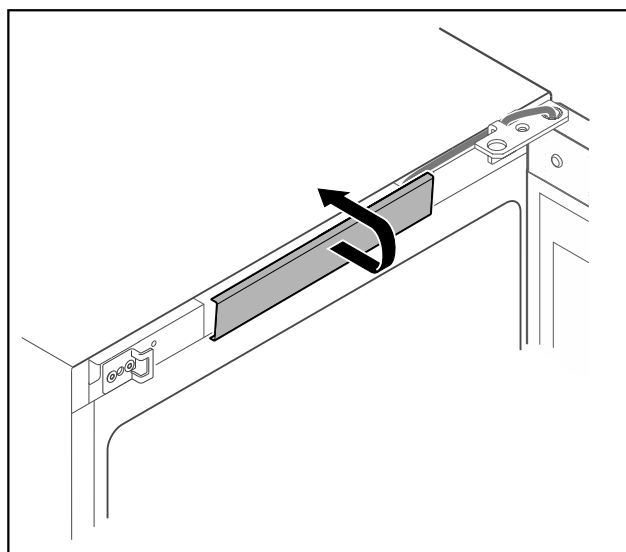

Fig. 16

- ▶ Unlatch the middle cover and remove it.

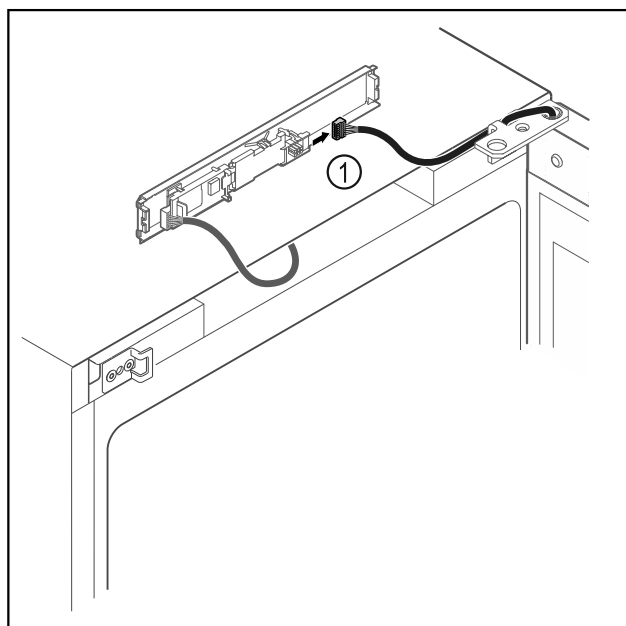

Fig. 17

- ▶ Disconnect the plug Fig. 17 (1) from the circuit board.

Putting into operation

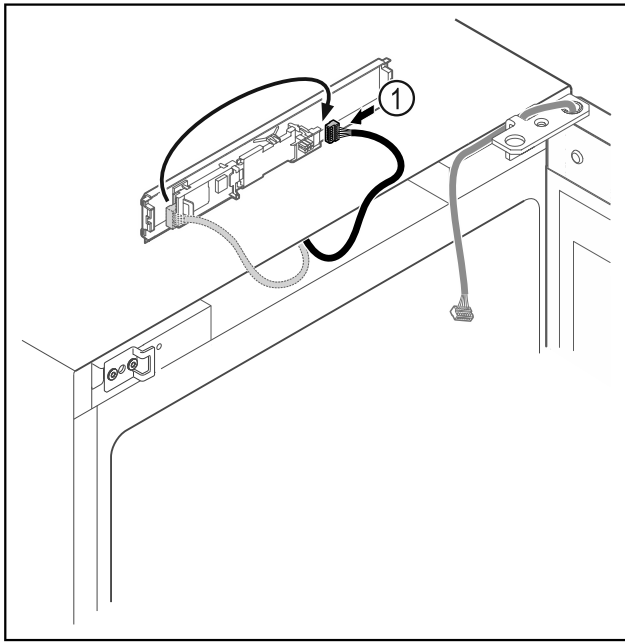

Fig. 18

- ▶ Connect the plug Fig. 18 (1) to the circuit board.

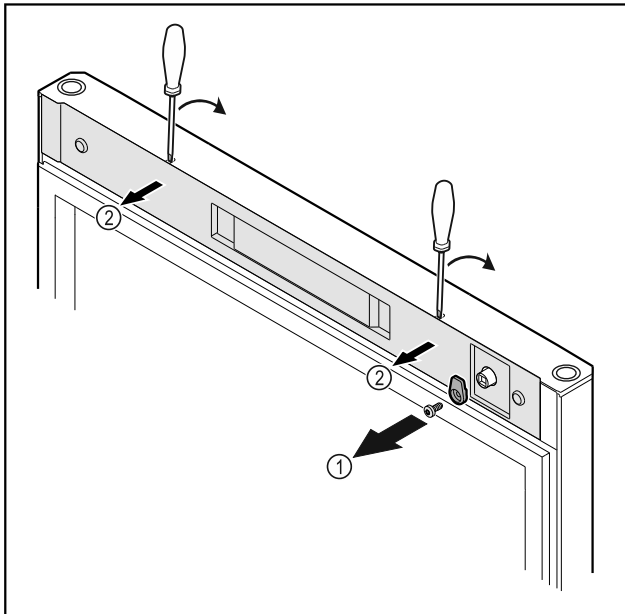

Fig. 19

- ▶ Unscrew the door latch Fig. 19 (1).
- ▶ Unlatch the cover Fig. 19 (1) with a small screwdriver and remove it.

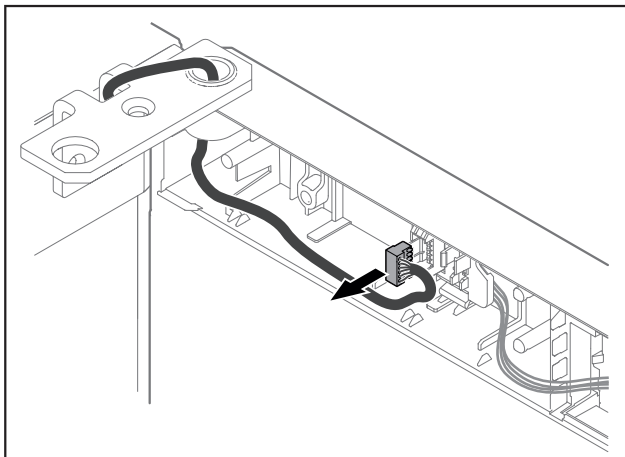

Fig. 20

- ▶ Remove the plug from the plug holder.

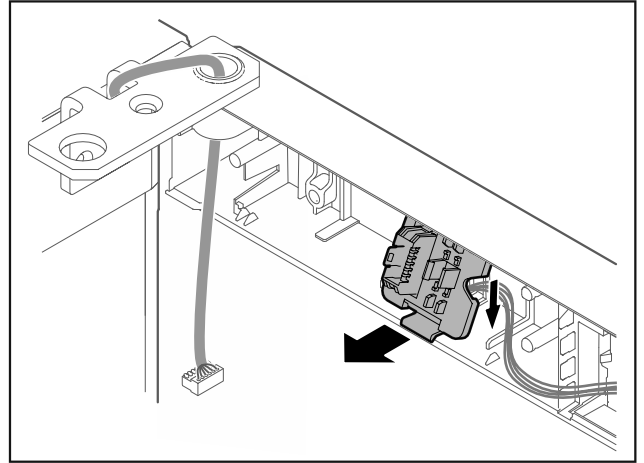

Fig. 21 The installation position of the plug holder can be rotated by 180°.

- ▶ Disengage the plug holder.

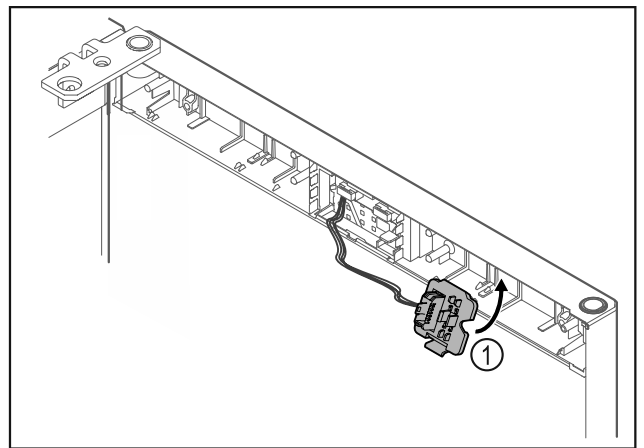

Fig. 22

- ▶ Snap in the plug holder Fig. 22 (1) on the opposite side.

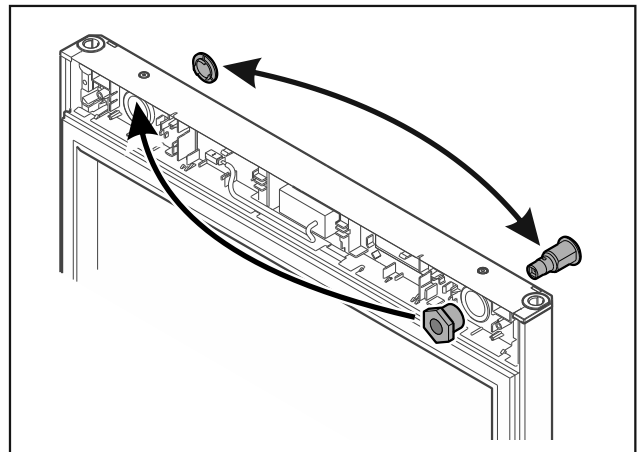

Fig. 23

- ▶ Put the lock and cover on the opposite side.

NOTICE

Risk of injury if the door tips out!

- ▶ Hold the door.

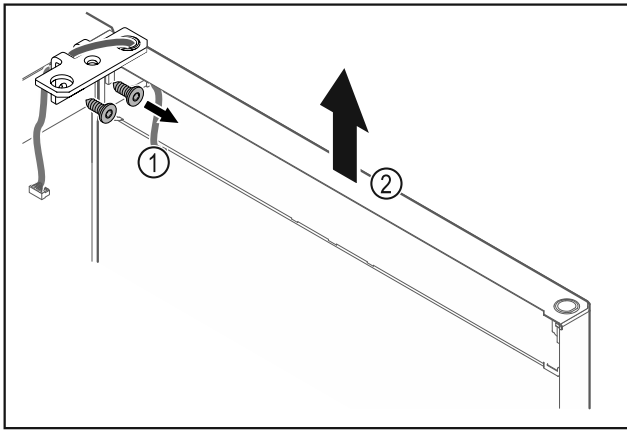

Fig. 24

- ▶ Unscrew the hinge Fig. 24 (1).
- ▶ Lift the door with the hinge straight up by Fig. 24 (2) roughly 200 mm and take it off.
- ▶ Carefully place the door on a soft surface.

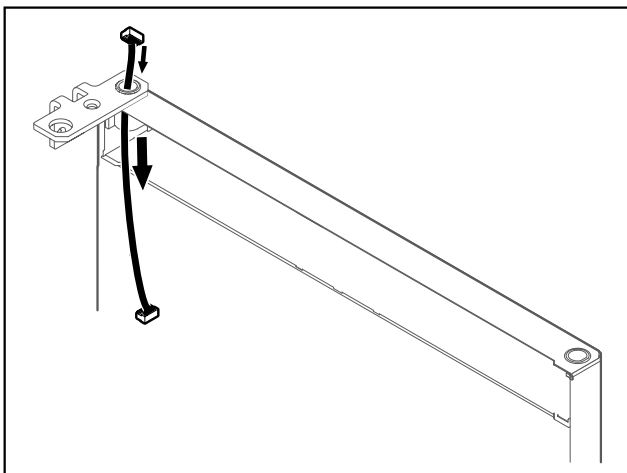

Fig. 25

- ▶ Carefully pull out the cable.

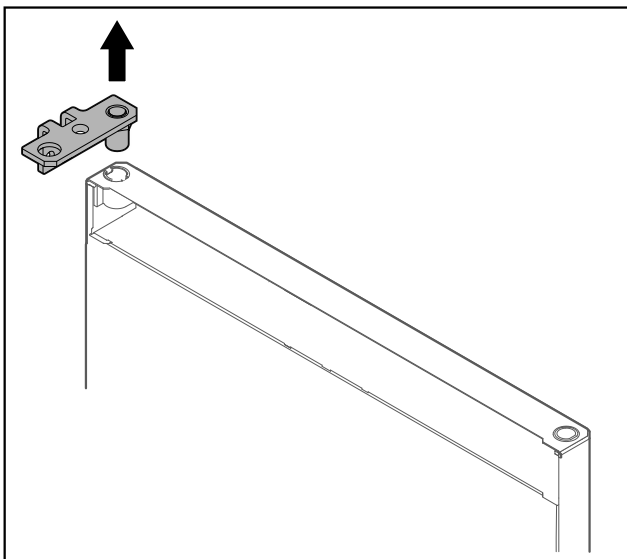

Fig. 26

- ▶ Pull out the hinge.

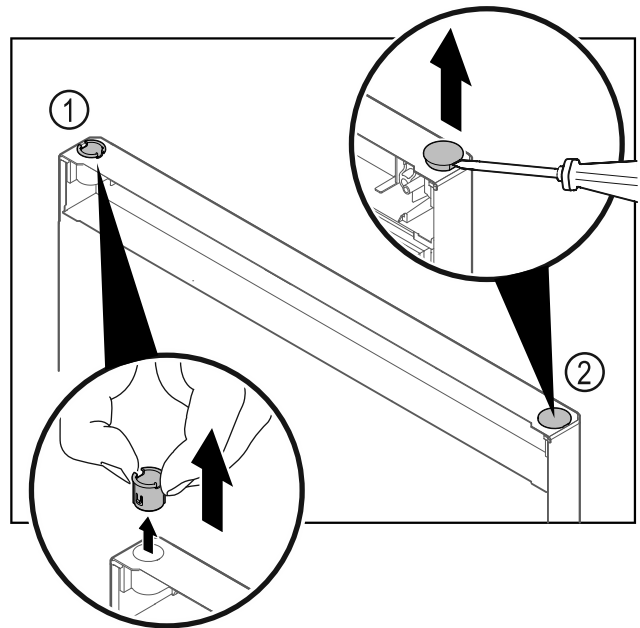

Fig. 27

- ▶ Pull out the hinge bushing Fig. 27 (1) with your fingers.
- ▶ Carefully lift the cover plug Fig. 27 (2) with a slotted screwdriver and pull it out.

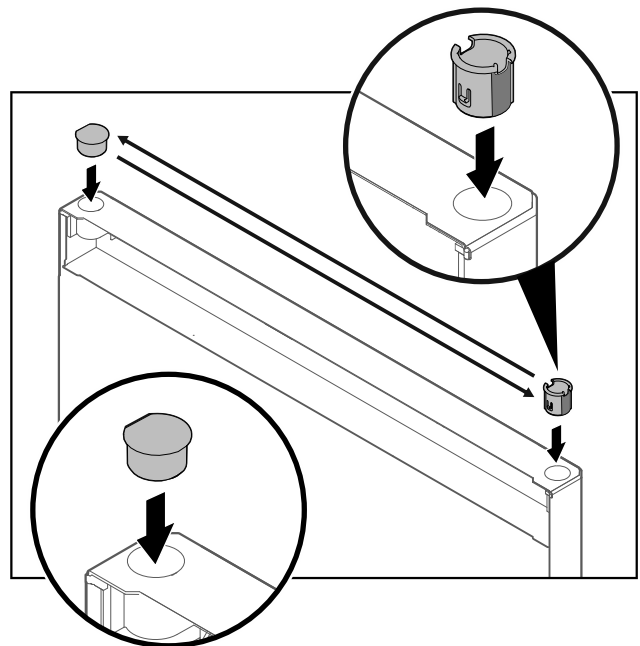

Fig. 28

- ▶ Insert hinge bushing and cover plug on the opposite side (the flattened sides face outwards).

Putting into operation

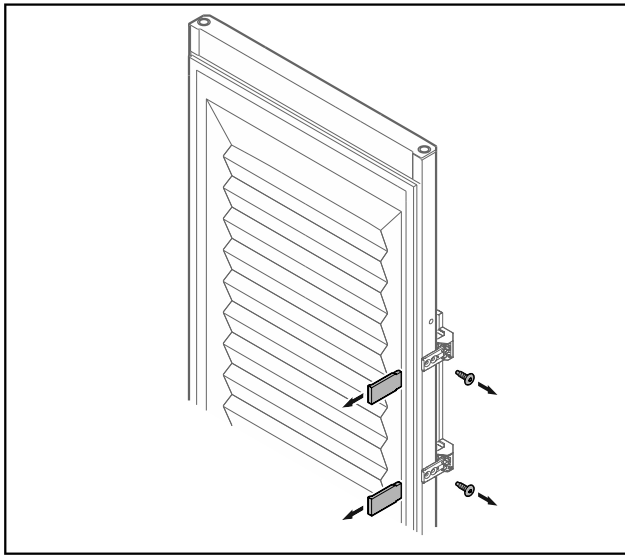

Fig. 29 Insulated door

- ▶ Remove the panels.
- ▶ Unscrew the handle.

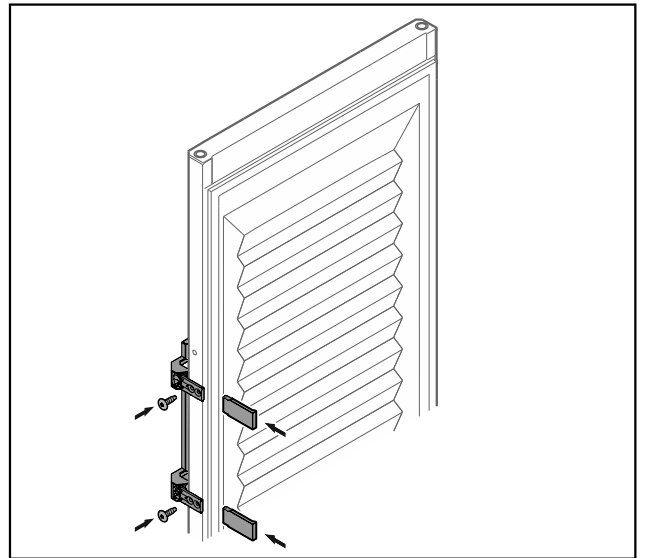

Fig. 31 Insulated door

- ▶ Screw the handle onto the opposite side.
- ▶ Attach the panels.

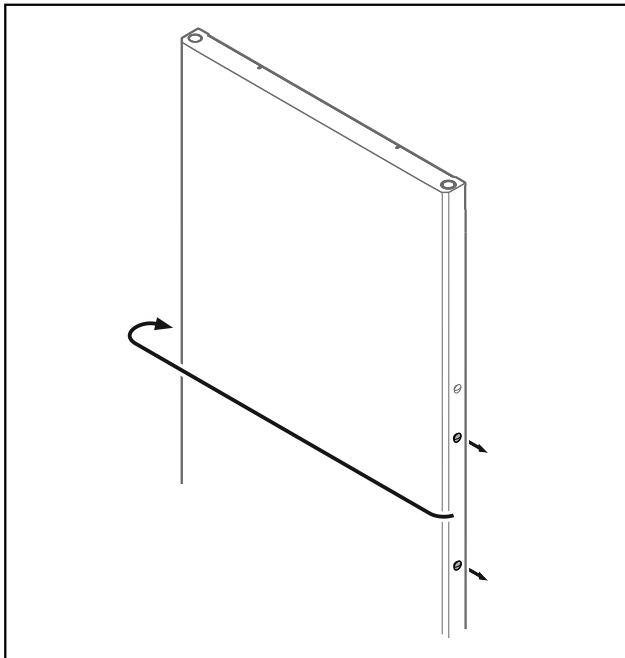

Fig. 30

- ▶ Put the stopper on the opposite side.

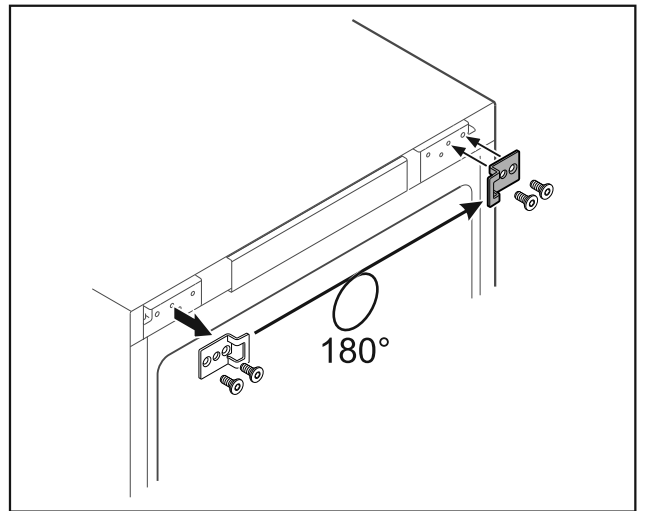

Fig. 32

- ▶ Put the closing bracket on the opposite side.

Note

The holes are pre-marked and must be pierced with the self-tapping screws.

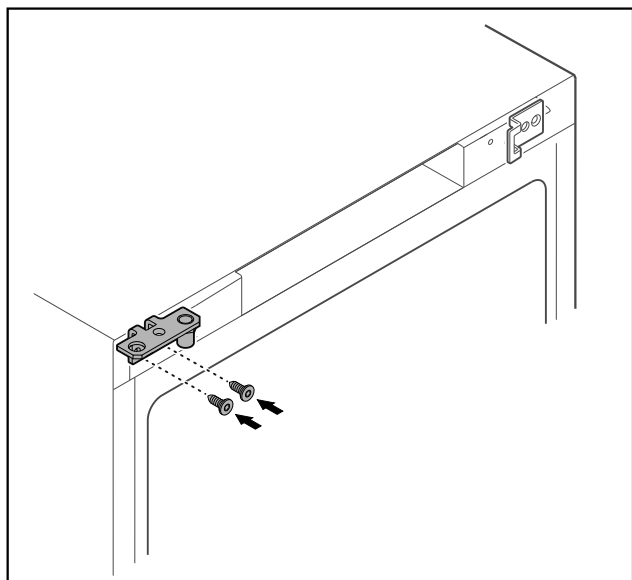

Fig. 33

- ▶ Move the hinge to the opposite side.



WARNING

Risk of injury and material damage if the door tips out!

- ▶ Tighten the bearing pins to the specified torque.

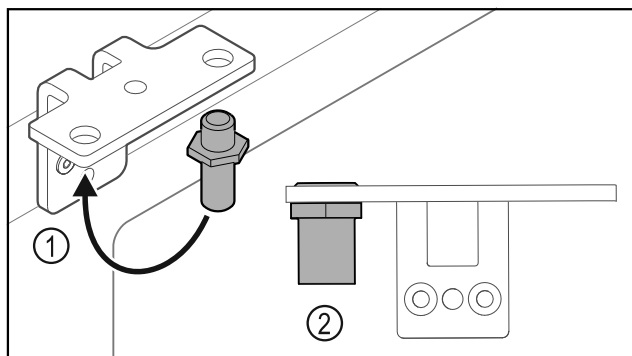

Fig. 34

- ▶ Put the pin back into the hinge Fig. 34 (1).
- ▶ Tighten the pin Fig. 34 (2) to a **torque of 12 Nm**.
- ▶ Unscrew the hinge again.

NOTICE

Risk of injury due to tensioned spring!

- ▶ Do not disassemble the door closing system Fig. 35 (1).

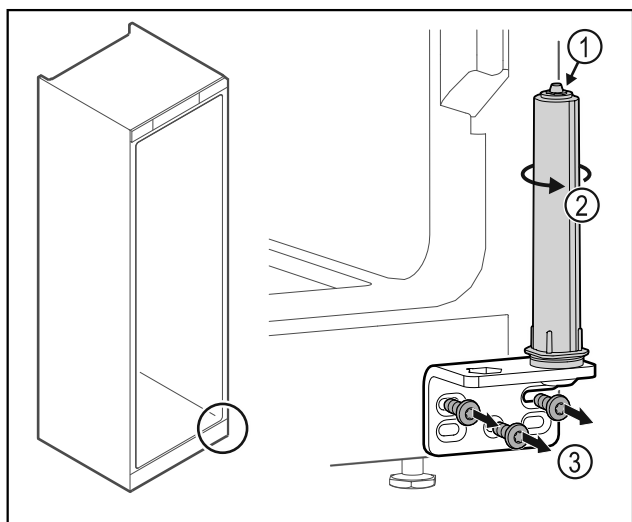

Fig. 35

- ▶ Turn the closing system Fig. 35 (2) until it clicks.
- ▶ The tension of the closing system is released.
- ▶ Unscrew the hinge Fig. 35 (3).

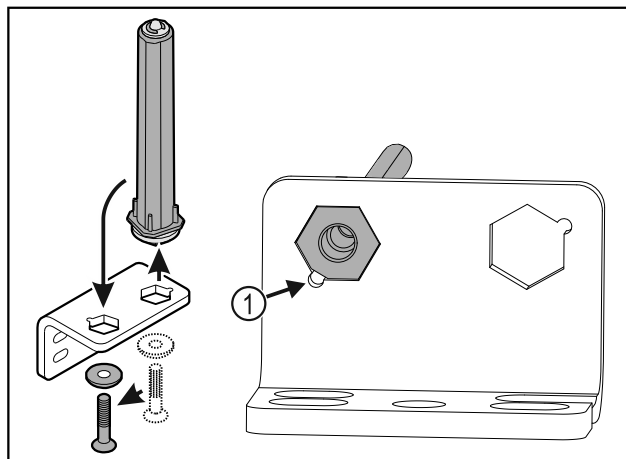

Fig. 36

- ▶ Put the door closing system in the hinge.
- ▶ Make sure the pin chamfer Fig. 36 (1) faces the round hole when you put it in.

-or-

Note

Incorrect alignment of the height adjustment washers. Nuts no longer have sufficient hold.

- ▶ The washer must lock into the underside of the closing system.

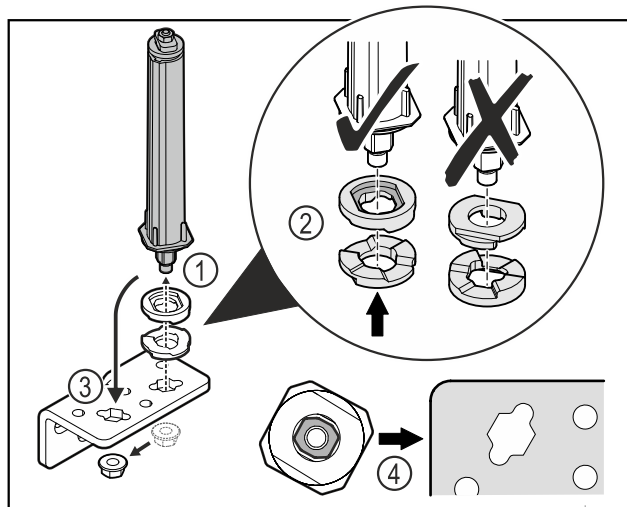

Fig. 37

- ▶ Loosen the nut and remove the door closing system Fig. 37 (1).
- ▶ Observe the correct alignment of the height adjustment washers Fig. 37 (2).
- ▶ Put the door closing system in the hinge and fix in place with the nut Fig. 37 (3).
- ▶ Observe the correct alignment of the door closing system when doing so Fig. 37 (4).

Putting into operation

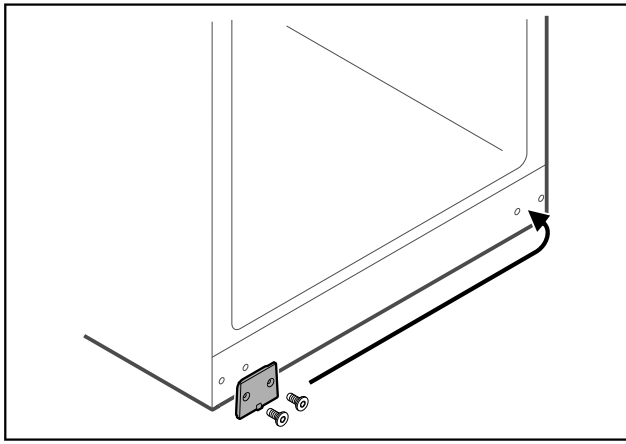

Fig. 38

- Put the cover plate on the opposite side.

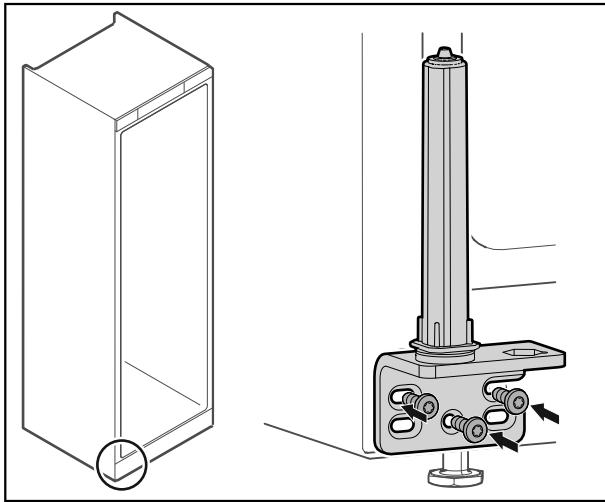

Fig. 39

- Screw the hinge onto the opposite side.

Note

Correct alignment and tension are important for the closing system to work properly.

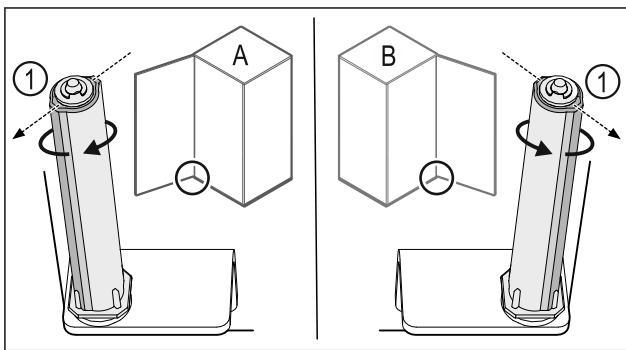

Fig. 40 Left-hinged (A) / Right-hinged (B)

- Turn the closing system against the resistance until the bar of the closing system Fig. 40 (1) points outwards.
- ▷ The closing system automatically stays in this position.
- ▷ The closing system is now aligned and tensioned.

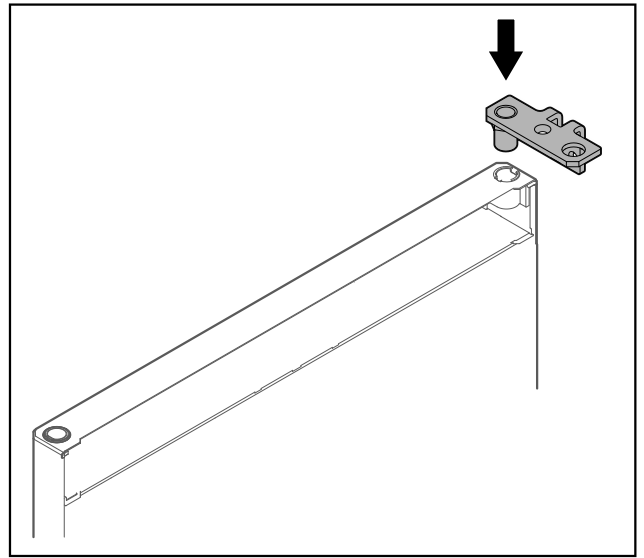

Fig. 41

- Put the hinge into the door.

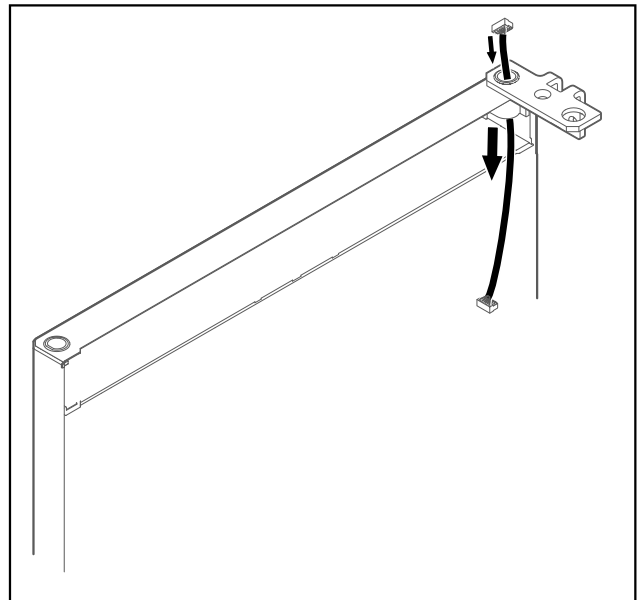

Fig. 42

- Carefully push the cable through.

NOTICE

Risk of injury if the door tips out!

- Hold the door.

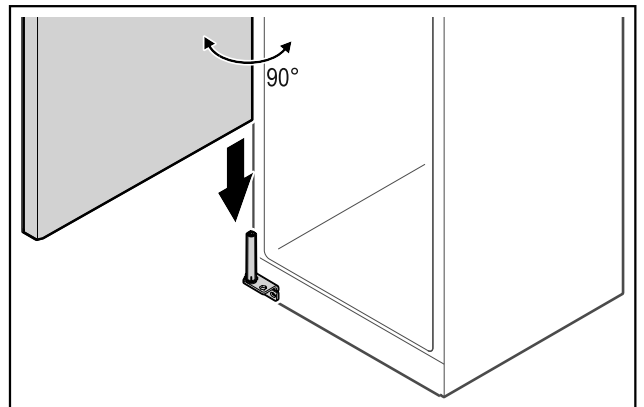

Fig. 43

- Together with a second person, lift the door from the ground.

- ▶ Carefully put the door on the closing system with the door opened at a 90° angle.

NOTICE

Material damage due to incorrect mounting!

- ▶ Do not pinch the cable when mounting the hinge.

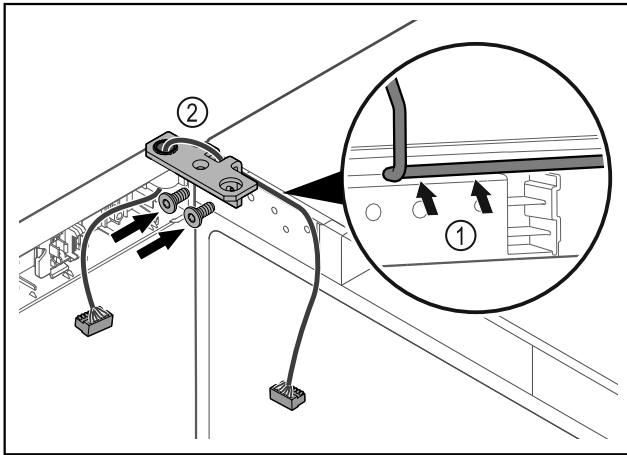

Fig. 44

- ▶ Feed the cable through the recess in the hinge and lay it carefully Fig. 44 (1).
- ▶ Screw on the hinge Fig. 44 (2).

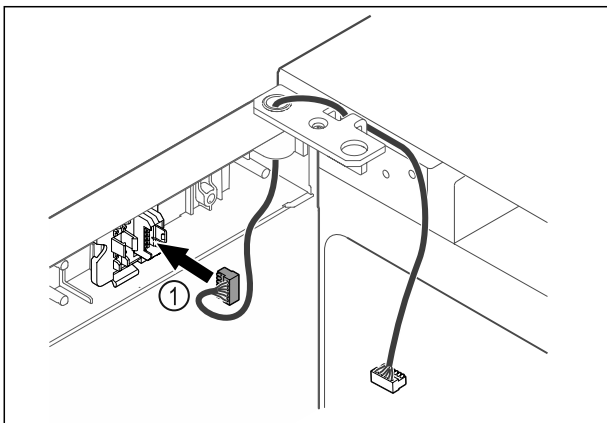

Fig. 45

- ▶ Put the plug Fig. 45 (1) in the plug holder.

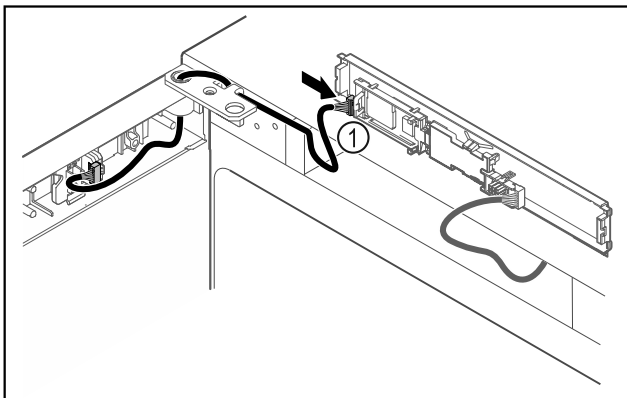

Fig. 46

- ▶ Connect the plug Fig. 46 (1) to the circuit board.

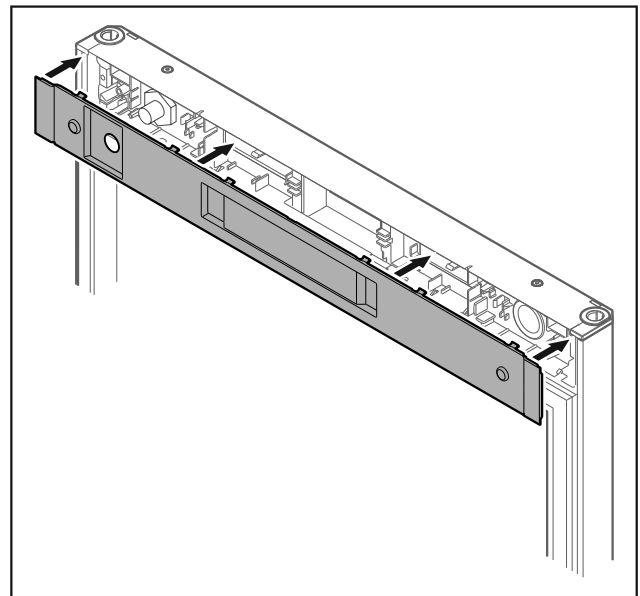

Fig. 47

- ▶ Set the cover back in place.

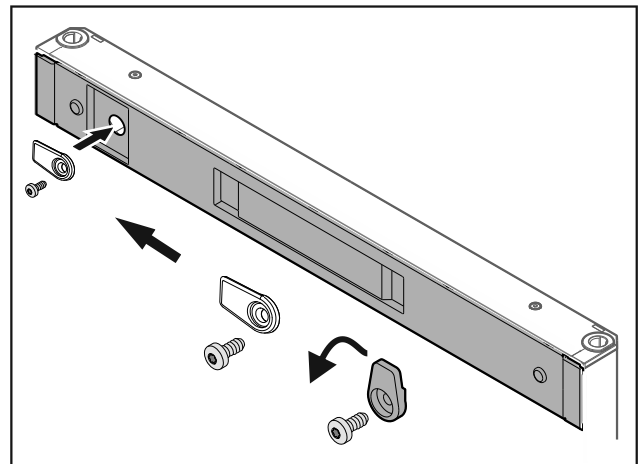

Fig. 48

- ▶ Screw on the door latch.

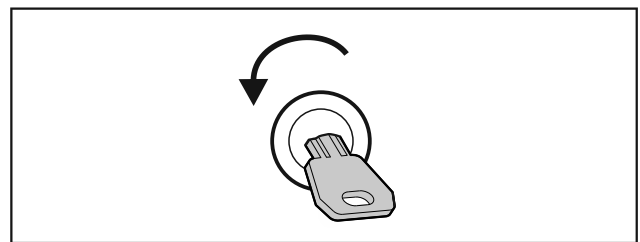

Fig. 49

- ▶ Open the door.

Putting into operation

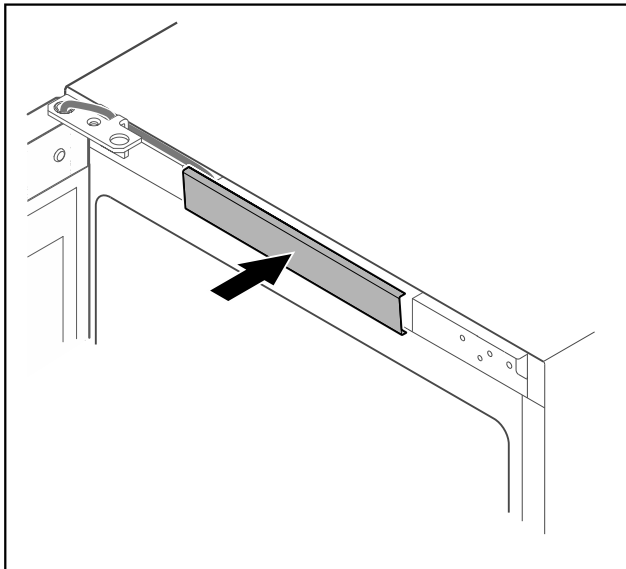

Fig. 50

- ▶ Snap in the middle cover.

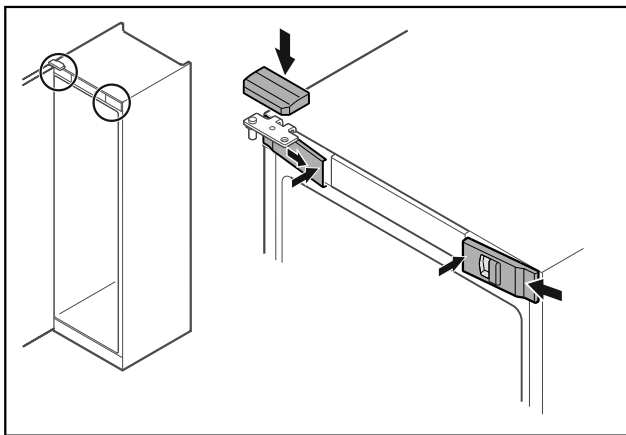

Fig. 51

- ▶ Hook in the front covers Fig. 51 (1) on the side and snap them into place on the inside.
- ▶ Snap on the top cover Fig. 51 (2) from above.
- ▶ Close the door.
- ▷ The door has now been reversed.

3.14 Aligning the door

If the door is not straight, you can adjust it on the lower hinge.

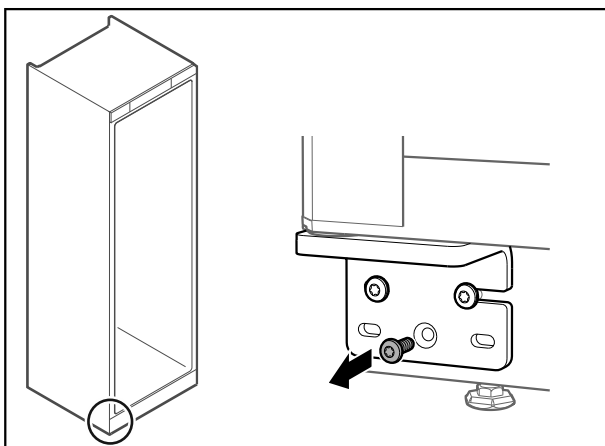

Fig. 52

- ▶ Remove the middle screw on the lower hinge.

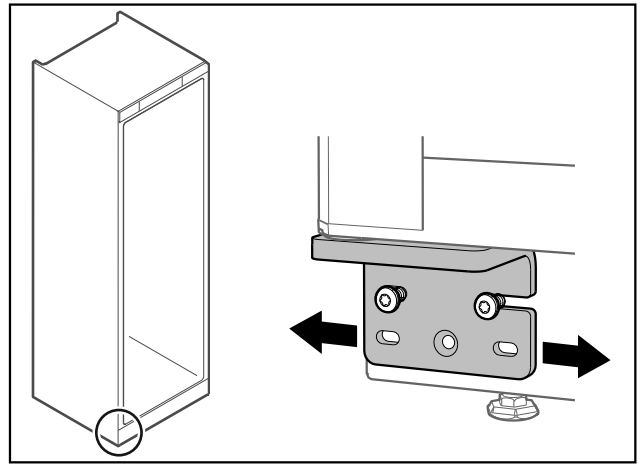

Fig. 53

- ▶ Slightly undo both screws and move the door with the hinge to the left or right.
- ▶ Fully tighten the screws (the middle screw is no longer needed).
- ▷ The door is now straight.

3.15 Connecting appliance



WARNING

Failure to connect properly
Fire hazard.

- ▶ Do not use an extension cable.
- ▶ Do not use distributor blocks.

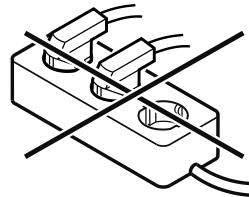

NOTICE

Failure to connect properly
Damage to the electronics.

- ▶ Do not connect the appliance to a stand-alone inverter, e.g. solar power systems and petrol generators.

Note

Only use the supplied mains cable.

Make sure the following prerequisites are met:

- The appliance is operated using **alternating current** only.
- The permitted voltage and frequency is printed on the type plate. The type plate position can be seen in the appliance overview chapter. (see 1.2 Overview of appliance and equipment)
- The socket is earthed according to the regulations and fused.
- The fuse tripping current is between 10 A and 16 A.
- The socket is easily accessible.
- ▶ Check the electrical connection.
- ▶ Insert the appliance plug into the back of the appliance. Ensure that they latch into place.
- ▶ Connect the mains plug to the power supply.
- ▷ The display switches to the standby symbol.

3.16 Switching on appliance (first use)

Make sure the following prerequisites are met:

- Appliance is installed and connected.
- All adhesive strips, adhesive and protective films and transport locks are removed from inside and outside the appliance.

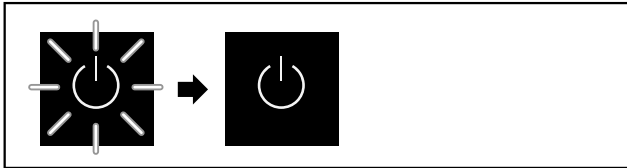

Fig. 54 Startup process

The standby symbol flashes until the startup process is complete.

The standby symbol is shown in the display.

If the appliance has been supplied with factory settings, the screen language first needs to be selected when using for the first time.

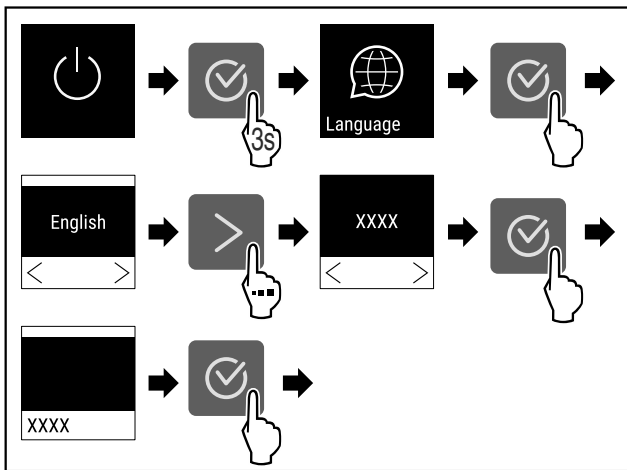

Fig. 55

► Complete steps (see Fig. 55) .

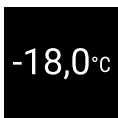

Fig. 56

► The appliance is switched on once the temperature appears in the display.

4 Storage

4.1 Information regarding storage

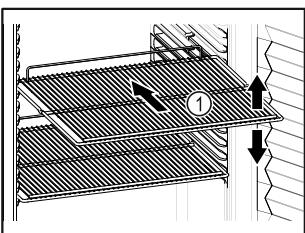

Fig. 57

When stocking observe the following:

- If there are adjustable shelves Fig. 57 (1), position them as required.
- Observe maximum load. (see 8.1 Technical specifications)

- Do not load appliance until storage temperature has been reached (maintain cold chain).
- Items for refrigeration must not come into contact with the evaporator on the rear wall.
- Keep liquids in closed containers.
- Leave space when storing items for refrigeration to ensure good air circulation.

4.2 Storage times

The best-before date specified on the packaging should be used as the reference point for the storage time.

5 Controls

5.1 Control and display elements

The display provides a quick overview of the current appliance status, the temperature setting, the status of functions and settings as well as alarm and error messages.

It is operated using the navigation arrows and confirmation symbol.

Functions can be activated or deactivated and setting values can be changed.



Fig. 58 Display

- (1) Status display
- (2) Backwards navigation arrow
- (3) Forward navigation arrow
- (4) Confirm

5.1.1 Status display











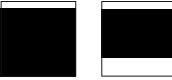



Fig. 59 Status display with actual temperature

The status display shows the actual temperature and is the home display. You navigate from here to the other functions and settings. (see 5.2 Navigation) The status display may show a range of display symbols.

5.1.2 Display symbols

Display symbols provide information about the status of the appliance.

Symbol	Appliance status
	Standby Appliance is switched off.
	Flashing standby symbol Appliance is starting up.
	Flashing temperature Target temperature not yet reached. Appliance cooling to temperature set.
	Temperature display Displays the current interior temperature
	D in the display Appliance is in DemoMode.
	Maintenance reminder The time interval set has expired.
	Data memory full The data memory (999 hours) is full. From now, the oldest data will be overwritten.
	Flashing symbol A fault is still active.
	Error symbol Appliance is in error state.
	White bar at the bottom Submenu
	White bar at the top Default, active setting or active value
	Increasing bar Press button for 3 seconds to activate setting.
	Decreasing bar Press button for 3 seconds to deactivate setting.

Status display symbols

5.1.3 Acoustic signals

A signal sounds in the following cases:





- If a function or a value is confirmed.
- If a function or a value can either not be activated or not deactivated.
- As soon as an error occurs.
- If there is an alarm message.

The alarms can be switched on and off in the customer menu.

5.2 Navigation

Navigate in the menu to access the individual functions. Operation using buttons next to the display.

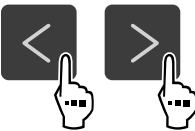
5.2.1 Navigating using buttons

Display and button	Description
	Forwards navigation arrow Advances to next menu (submenu). It returns to the first menu page after the last menu page.
	Backwards navigation arrow Press briefly: Goes back one menu (submenu). Press and hold (3 seconds): Goes back to status display.
	Pressing multiple times Navigates within the menu.
	Confirm Activates / deactivates function. Confirms selection. Opens submenu.
	Back Jumps back one level.

5.2.2 Settings menu

You can access additional appliance functions via the Settings menu.

Opening the Settings menu

- ▶ Tap the navigation arrow repeatedly until the corresponding function is displayed.



Fig. 60

- ▶ Carry out steps according to the illustration.

-or-

- ▶ Enter access protection PIN code for the Settings menu. (see 5.3.5 Settings menu access protection)

- ▷ The Settings menu opens.

Settings menu access protection

(see 5.3.5 Settings menu access protection)

5.2.3 Customer menu

The Customer menu is protected by the code **151**. You can access additional appliance functions.

Opening the Customer menu

- ▶ Opening the Customer menu (see 5.2 Navigation) .
- ▶ Tap the navigation arrow repeatedly until the corresponding function is displayed.

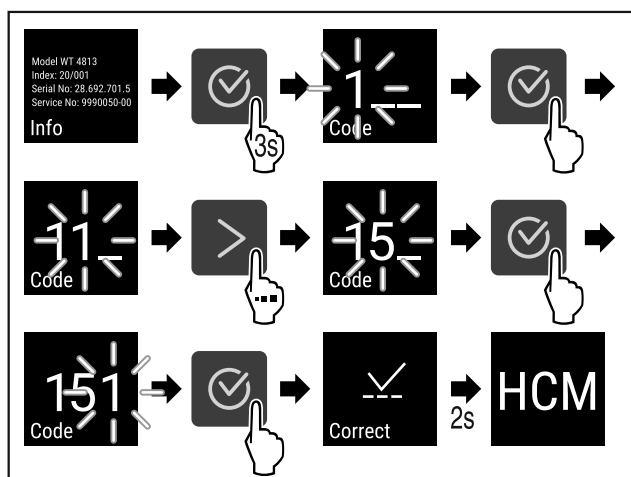

Fig. 61

- ▶ Carry out steps according to the illustration.
- ▷ The customer menu opens.

5.2.4 Setting values

Values displayed can be set in the submenu in combination with the navigation arrow:

Display and button	Description
	Increases a value.
	Reduces a value.

5.2.5 General rules

The following general rules apply in addition to the buttons available:

- Once a value has been selected, the display is shown for 2 seconds before jumping back one level.
- If no selection is made after 10 seconds, the display switches to the status display.
- If a selection is confirmed in a submenu, the display switches back to the menu.

5.3 Functions

5.3.1 Overview of functions

Switch appliance on and off

Temperature recording

Settings

Access to this function can be blocked using a PIN code. (see 5.3.5 Settings menu access protection)

Info

Temperature

Temperature alarm

Door alarm

Alarm simulation

Alarm relay

Sensor calibration

Maintenance interval reminder

Language

Temperature unit

Screen brightness

LAN *

WiFi *

Operating hours

Software

Settings lock

Settings lock code

Button sounds

Controls



Alarm sounds



DemoMode



Factory reset

5.3.2 Switching appliance on and off



Using this setting the entire appliance can be switched on and off.

Switching on appliance

Without activated DemoMode:

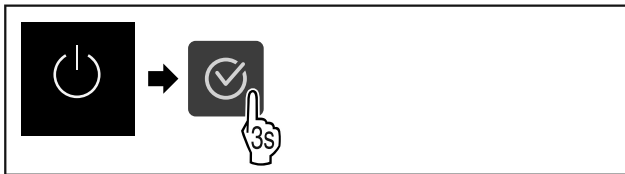

Fig. 62

▶ Complete the steps.

With activated DemoMode:

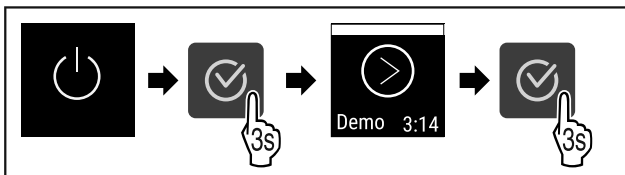

Fig. 63

▶ Complete the steps.

Note

Deactivate DemoMode before countdown finishes.



Fig. 64

▷ The temperature appears in the display.

Switching off appliance

- ▶ Call up the settings menu. (see 5.2 Navigation)
- ▶ Tap the navigation arrow repeatedly until the corresponding function is displayed.

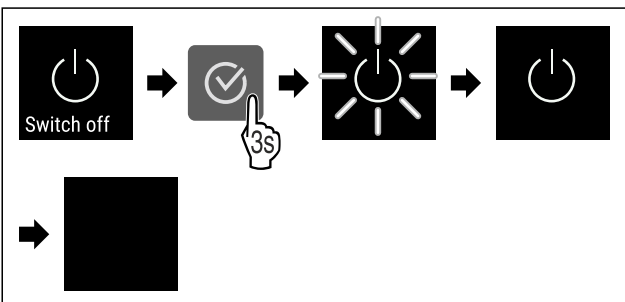

Fig. 65

- ▶ Complete the steps.
- ▷ Standby symbol is shown in the display.
- ▷ Display switches off after approximately 10 minutes.



5.3.3 Temperature

The temperature depends on the following factors:

- How often the door is opened
- How long the door is open for
- The room temperature of the installation site
- The type, temperature and amount of frozen food

Note

The temperature may differ from the temperature displayed in some areas of the interior.

Setting temperature

- ▶ Call up settings menu. (see 5.2 Navigation)
- ▶ Tap the navigation arrow repeatedly until the corresponding function is displayed.

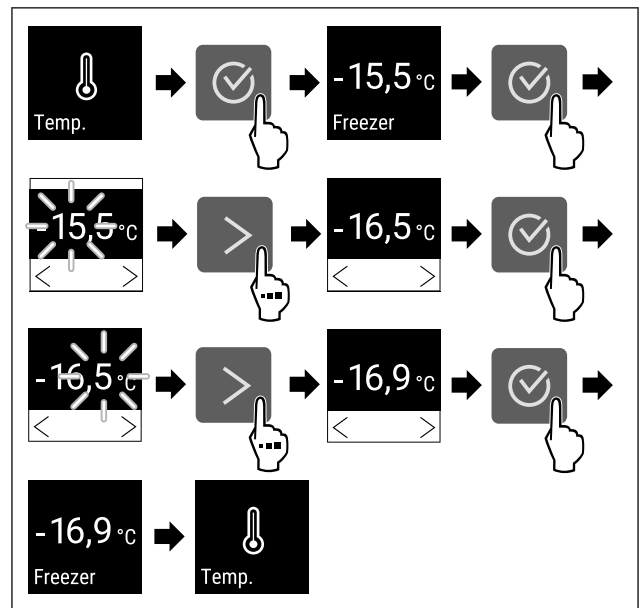

Fig. 66 Changing temperature from -15.5°C to -16.9°C

- ▶ Complete steps (see Fig. 66).
- ▷ Temperature is set.



5.3.4 Temperature recording

The appliance displays the minimum and maximum temperatures of the interior. The recording of these temperatures starts automatically after the appliance is switched on; they are recorded at one minute intervals. A note indicating that the data memory is full is displayed after 999 hours (approx. 40 days). The temperature recording should then be reset.

Note

We recommend resetting the temperature recording once **after reaching the set temperature** when the appliance is commissioned. This ensures that the value displayed for the maximum temperature is a meaningful value.

Displaying temperature recording

The temperature recording displays the length of the recording and the minimum and maximum temperatures measured during this period of time.



Fig. 67

- ▶ Tap navigation arrow repeatedly until corresponding functions are displayed.
- ▷ Status screen with the temperature recordings is displayed.

Resetting temperature recording

The displayed minimum and maximum temperatures can be reset at any time. This deletes the displayed values and the recording interval starts again.

- ▶ Tap navigation arrow repeatedly until corresponding function is displayed.

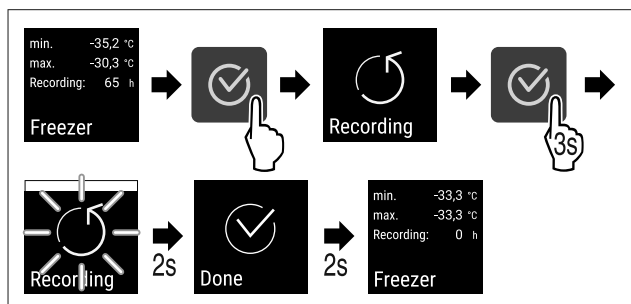

Fig. 68

- ▶ Carry out steps according to the illustration.
- ▷ Temperature recording is reset.
- ▷ Recording interval starts again.



5.3.5 Settings menu access protection

This setting enables the settings menu access protection via a three-digit PIN code.

Application:

- Prevent settings and functions being changed unintentionally.
- Prevent appliance being switched off unintentionally.
- Avoid unintentional temperature adjustment.

Activating the settings menu access protection

- ▶ Call up customer menu. (see 5.2 Navigation)
- ▶ Tap navigation arrow repeatedly until corresponding function is displayed.

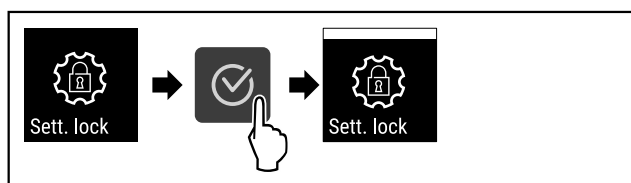

Fig. 69

- ▶ Complete the steps.
- ▷ Settings menu access protection is activated.

Changing the access protection PIN code for the settings menu

See: (see 5.3.6 Access code)

Deactivating the settings menu access protection

- ▶ Call up customer menu. (see 5.2 Navigation)
- ▶ Tap navigation arrow repeatedly until corresponding function is displayed.

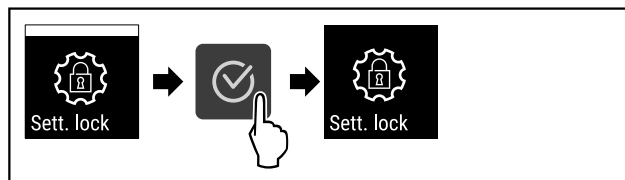

Fig. 70

- ▶ Complete the steps.
- ▷ Settings menu access protection is deactivated.

Opening protected settings menu

If the access protection is active, it is necessary to enter the PIN code to open the settings menu.

After entering the correct PIN code, the settings menu remains unlocked for 20 minutes unless you jump back to the status display.

Note

- ▶ In the following example, the factory-set PIN code: 1 1 1 is used.

- ▶ **Access protection for the settings menu must be active.**
- ▶ Tap navigation arrow repeatedly until corresponding function is displayed.

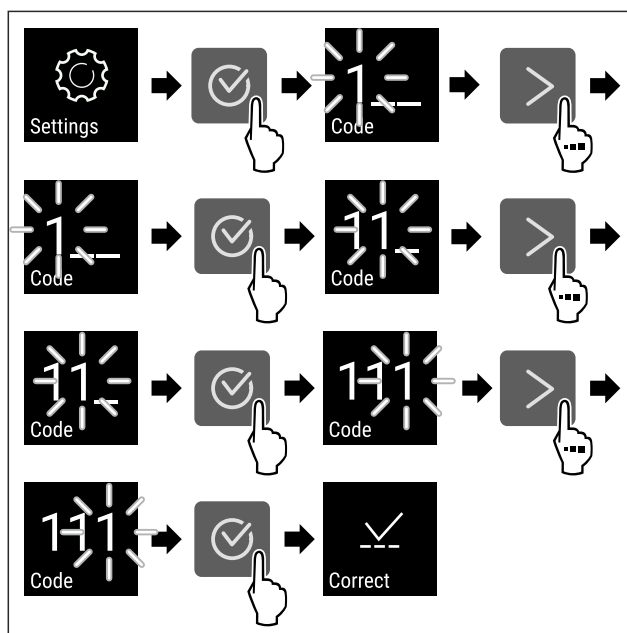

Fig. 71

- ▶ Complete the steps. Enter PIN code.
- ▷ The PIN code is correct.
- ▷ The settings menu opens.

5.3.6 Access code

Various settings are possible.

Application:

- Changing the settings code.
- Resetting the settings code.



Settings menu access protection

Changing the settings code

This setting allows the settings code for settings menu access protection to be changed.

The setting is made in 3 stages:

- Entering the old settings code

Controls

- Entering the new settings code
- Confirming the new settings code

Note

- ▶ In the following example, the default factory-set settings code **1 1 1** is changed.
 - ▶ The new settings code is: **2 3 4**
- ▶ Open customer menu. (see 5.2 Navigation)
 - ▶ **The access protection for the settings menu must be active.** (see 5.3.5 Settings menu access protection)
 - ▶ Tap the navigation arrow repeatedly until the corresponding function is displayed.

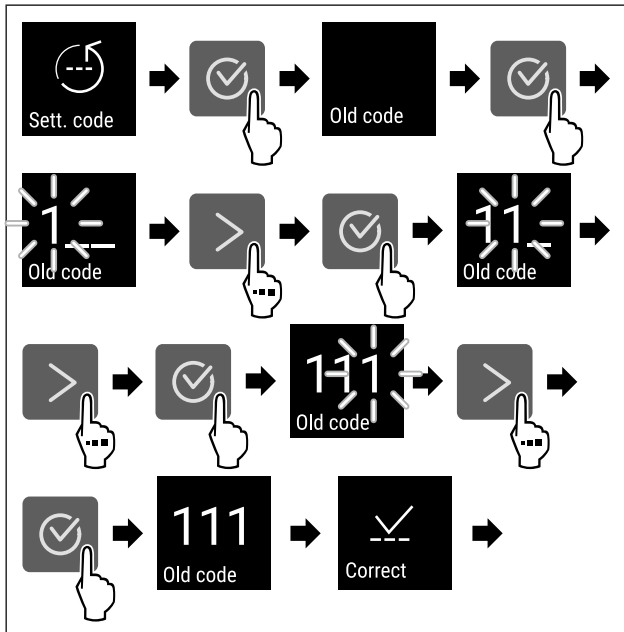

Fig. 72

- ▶ Complete the steps.
- ▷ Entry of the old settings code successful.

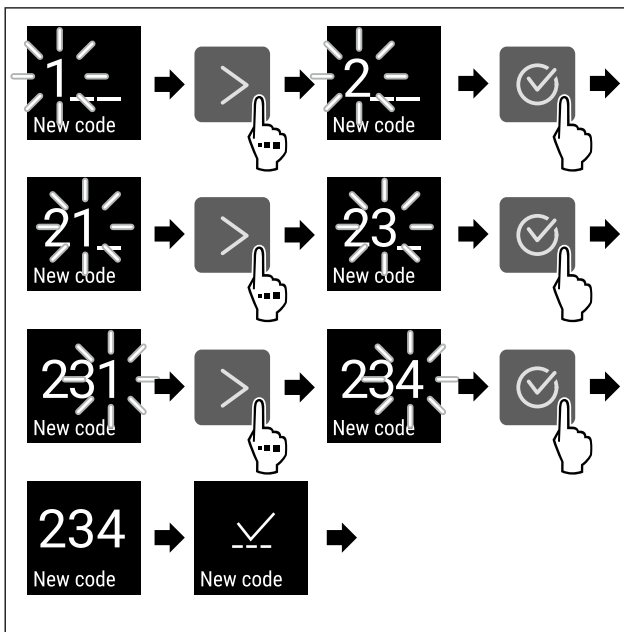

Fig. 73

- ▶ Complete the steps.
- ▷ Entry of the new settings code successful.

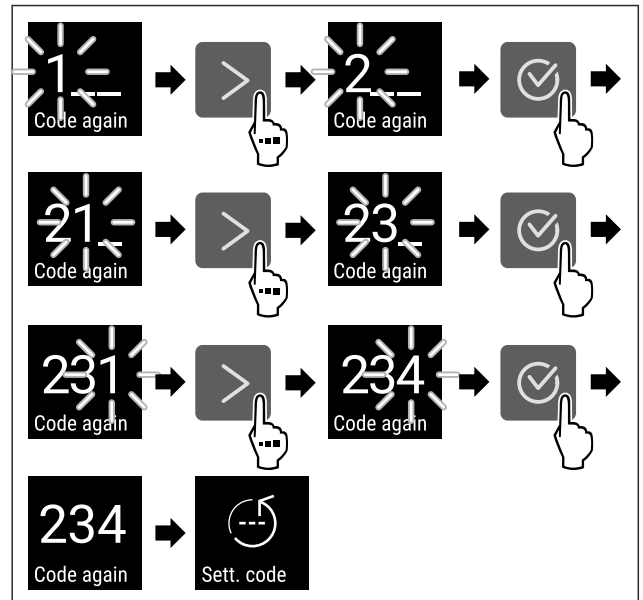

Fig. 74

- ▶ Complete the steps.
- ▷ Confirmation of the new settings code successful.
- ▷ The settings code has been changed.

Resetting the settings code

The settings code for the settings menu access protection has been forgotten or is not known.

- ▶ Reset appliance to factory settings (see 5.3.24 Factory reset).
- ▷ The appliance is reset to the original settings.
- ▷ The factory-set settings code is: **1 1 1**



5.3.7 Maintenance interval reminder

Setting for the time interval after which a maintenance reminder is issued.

The following values can be set:

- 7 days
- 14 days
- 30 days
- 60 days
- 90 days
- 180 days
- 360 days
- 720 days
- 1080 days
- Off

Setting maintenance interval reminder

The following steps describe how the maintenance interval is set.

- ▶ Call up settings menu. (see 5.2 Navigation)
- ▶ Tap navigation arrow repeatedly until corresponding function is displayed.

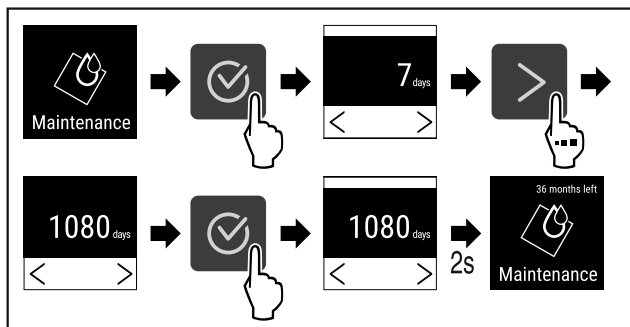

Fig. 75

- ▶ Complete steps (see Fig. 75) .
- ▷ The time interval, after which the maintenance reminder is issued, is set.
- ▷ The remaining time is displayed.



5.3.8 Language

This setting allows the display language to be set.

Setting language

- ▶ Open settings menu (see 5.2 Navigation) .
- ▶ Tap the navigation arrow repeatedly until the corresponding function is displayed.

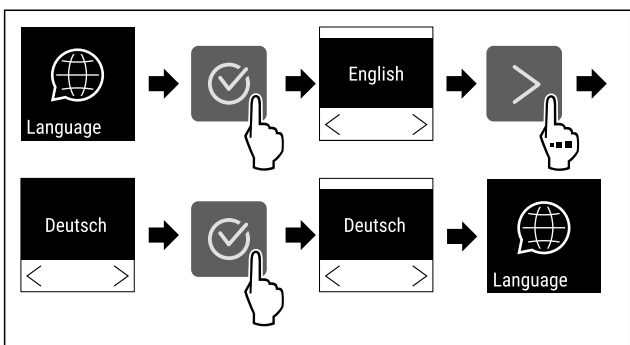

Fig. 76

- ▶ Complete the steps.
- ▷ The selected language is set.



5.3.9 Temperature unit

This setting allows the temperature unit to be changed between degrees Celsius and Fahrenheit.

Setting temperature unit

The example shows how you change the temperature unit from degrees Celsius to Fahrenheit.

- ▶ Open settings menu (see 5.2 Navigation) .
- ▶ Tap the navigation arrow repeatedly until the corresponding function is displayed.

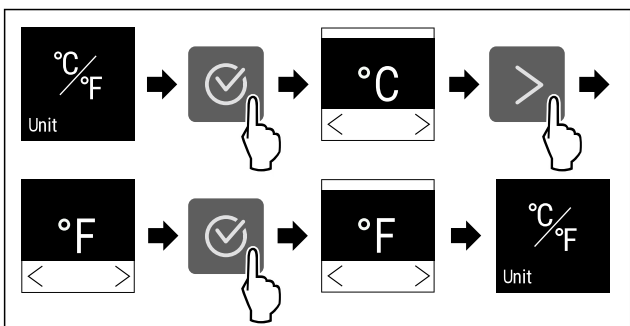

Fig. 77

- ▶ Complete the steps.
- ▷ The temperature unit is set as Fahrenheit.

5.3.10 Display brightness



This setting allows the display brightness to be adjusted incrementally.

The following brightness values can be set:

- 40%
- 60%
- 80%
- 100% (default)

Setting display brightness

The following steps describe how to reduce the display brightness, e.g. from 100 % to 40 %.

- ▶ Open settings menu (see 5.2 Navigation) .
- ▶ Tap the navigation arrow repeatedly until the corresponding function is displayed.

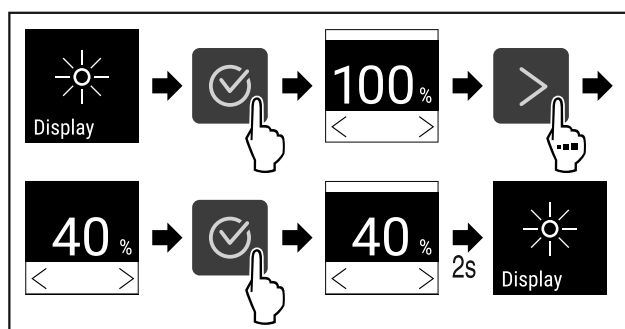

Fig. 78

- ▶ Complete the steps (see Fig. 78) .
- ▷ Display brightness changes accordingly.



5.3.11 Alarm Sound

This function enables all alarm sounds, such as door alarm, to be switched on and off.

Activating Alarm Sound

- ▶ Call up customer menu. (see 5.2 Navigation)
- ▶ Tap the navigation arrow repeatedly until the corresponding function is displayed.

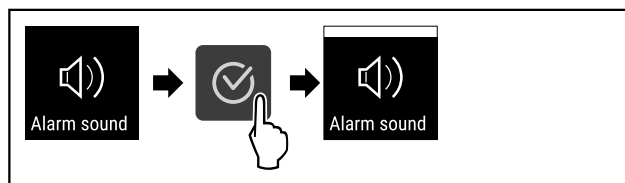

Fig. 79

- ▶ Complete the steps.
- ▷ Alarm Sound is activated.

Deactivating Alarm Sound

- ▶ Call up customer menu. (see 5.2 Navigation)
- ▶ Tap navigation arrow repeatedly until corresponding function is displayed.

Controls

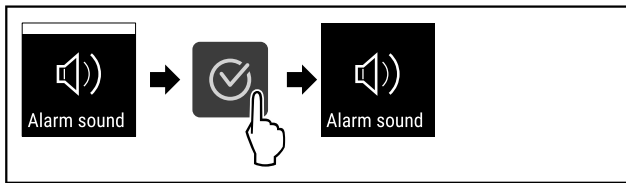

Fig. 80

- ▶ Complete the steps.
- ▷ Alarm Sound is deactivated.



5.3.12 Key Sound

This function makes it possible to switch all confirmation sounds and the Startsound on and off.

Activating Key Sound

- ▶ Call up customer menu. (see 5.2 Navigation)
- ▶ Tap navigation arrow repeatedly until corresponding function is displayed.

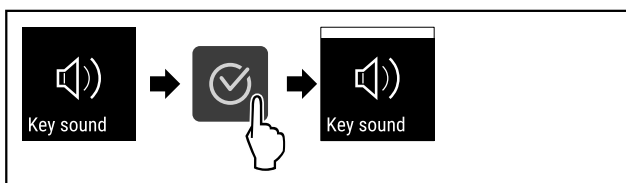

Fig. 81

- ▶ Complete the steps.
- ▷ Key Sound is activated.

Deactivating Key Sound

- ▶ Call up customer menu. (see 5.2 Navigation)
- ▶ Tap navigation arrow repeatedly until corresponding function is displayed.

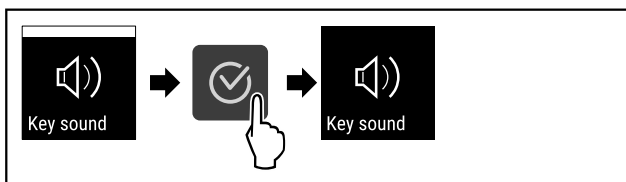

Fig. 82

- ▶ Complete the steps.
- ▷ Key Sound is deactivated.



5.3.13 WiFi connection

Note

Use of the Liebherr SmartMonitoring Dashboard at <https://smartmonitoring.liebherr.com> requires installation of a SmartModule and a commercial MyLiebherr account. When commissioning online you can register using the login data you have, or register again and create a company account.

This setting establishes a wireless connection between the appliance and the internet. The connection is controlled via the SmartModule. The appliance can be integrated via the browser-based [Liebherr SmartMonitoring Dashboard](https://smartmonitoring.liebherr.com) and advanced options as well as customised methods relating to control, administration and monitoring can be used.

Note

Accessories are available from Customer Service (see 8.3 Customer Service) and the Liebherr-Hausgeräte store at home.liebherr.com/shop/de/deu/zubehor.html.

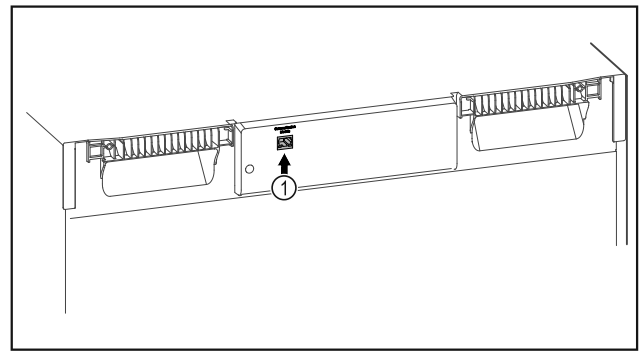

Fig. 83

Make sure that the following requirements are fulfilled:

- SmartModule Fig. 83 (1) is in use.

Establishing connection

You commission and set up your SmartModule online via the [Liebherr SmartMonitoring Dashboard](https://smartmonitoring.liebherr.com) on your web-enabled device.

On the [Liebherr SmartMonitoring Dashboard](https://smartmonitoring.liebherr.com), information is also available about retrofitting the SmartModule.



Fig. 84

- ▶ Open the [Liebherr SmartMonitoring Dashboard](https://smartmonitoring.liebherr.com) (see Fig. 84).

On the refrigerator or freezer:

- ▶ Open the settings menu (see 5.2 Navigation).
- ▶ Tap navigation arrow repeatedly until corresponding function is displayed.

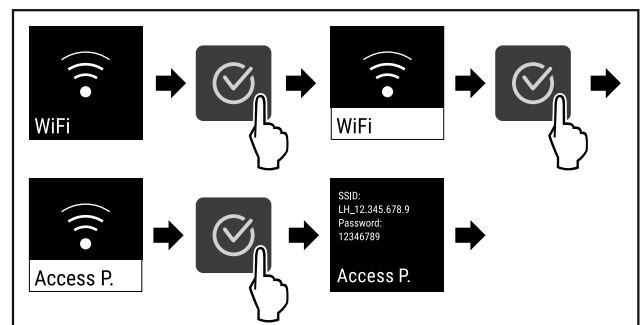

Fig. 85

- ▶ Complete the steps (see Fig. 85).
- ▶ Continue the set-up procedure on your web-enabled device: [Liebherr SmartMonitoring Dashboard](https://smartmonitoring.liebherr.com)

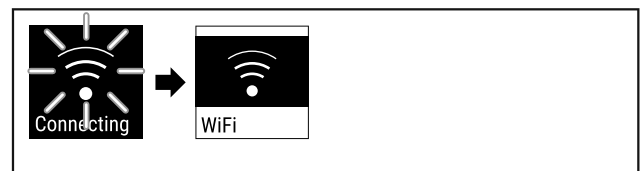

Fig. 86

- ▶ Connection is established (see Fig. 86).
- ▷ WiFi connecting appears. The symbol flashes.
- ▶ Follow the [Liebherr SmartMonitoring Dashboard](https://smartmonitoring.liebherr.com) instructions.
- ▷ Connection is established.

Disconnecting

- ▶ Open the settings menu (see 5.2 Navigation).

- ▶ Tap navigation arrow repeatedly until corresponding function is displayed.

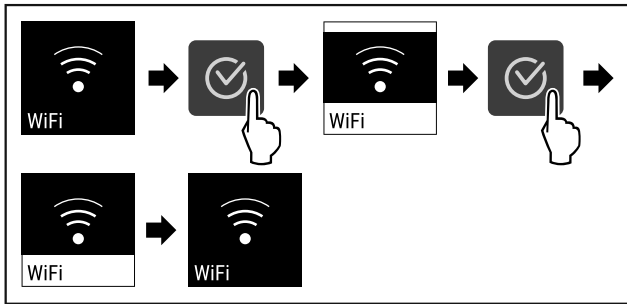

Fig. 87

- ▶ Complete the steps (see Fig. 87).
- ▷ There is no connection.

Resetting connection

- ▶ Open the settings menu (see 5.2 Navigation).
- ▶ Tap navigation arrow repeatedly until corresponding function is displayed.

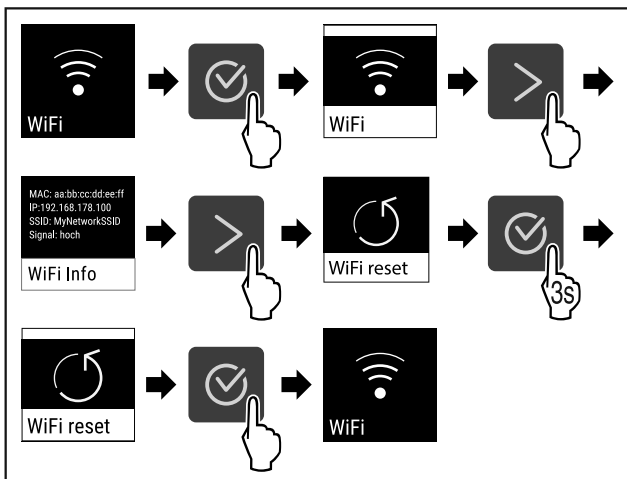

Fig. 88

- ▶ Complete the steps (see Fig. 88).
- ▷ The WiFi settings are restored to the factory settings.

5.3.14 LAN connection



Note

Use of the Liebherr SmartMonitoring Dashboard at <https://smartmonitoring.liebherr.com> requires installation of a SmartModule and a commercial MyLiebherr account. When commissioning online you can register using the login data you have, or register again and create a company account.

This setting establishes a wired connection between the appliance and the internet. The connection is controlled via the SmartModule. The appliance can be integrated via the browser-based [Liebherr SmartMonitoring Dashboard](#) and advanced options as well as customised methods relating to control, administration and monitoring can be used.

Note

Accessories are available from Customer Service (see 8.3 Customer Service) and the Liebherr-Hausgeräte store at home.liebherr.com/shop/de/deu/zubehor.html.

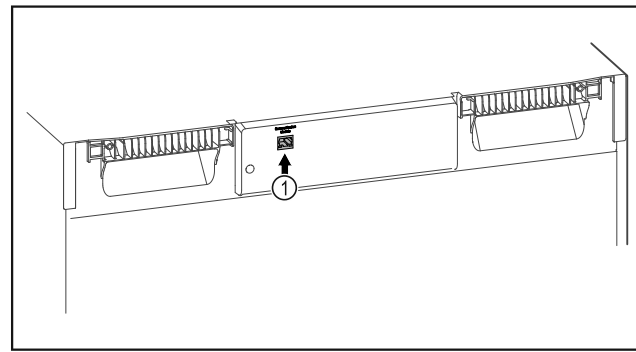

Fig. 89

Make sure that the following requirements are fulfilled:

- SmartModule Fig. 89 (1) is in use.
- A network cable is connected.

Establishing connection

You commission and set up your SmartModule online via the [Liebherr SmartMonitoring Dashboard](#) on your web-enabled device.

On the [Liebherr SmartMonitoring Dashboard](#), information is also available about retrofitting the SmartModule.



Fig. 90

- ▶ Open the [Liebherr SmartMonitoring Dashboard](#) (see Fig. 90).

On the refrigerator or freezer:

- ▶ Call up the settings menu. (see 5.2 Navigation)
- ▶ Tap navigation arrow repeatedly until corresponding function is displayed.

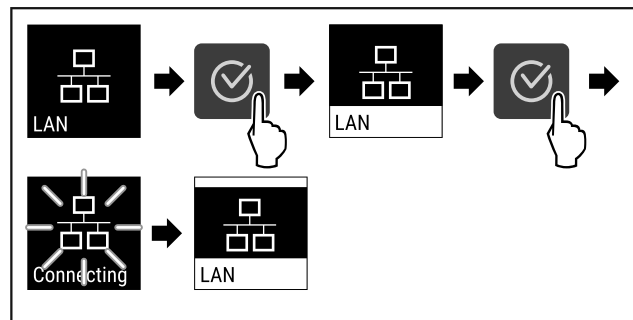

Fig. 91

- ▶ Complete the steps (see Fig. 91).
- ▷ Connection is established: LAN connecting appears. The symbol flashes.
- ▶ Follow the [Liebherr SmartMonitoring Dashboard](#) instructions.
- ▷ Connection is established.

Disconnecting

- ▶ Call up the settings menu. (see 5.2 Navigation)
- ▶ Tap navigation arrow repeatedly until corresponding function is displayed.

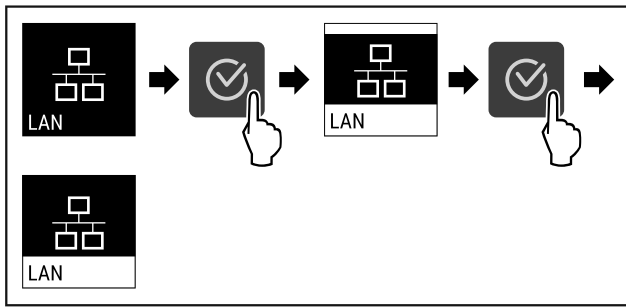

Fig. 92

- ▶ Complete the steps (see Fig. 92).
- ▷ There is no connection.



5.3.15 Info

This display shows the model, serial number and service number of the appliance.

Displaying Info

- ▶ Tap the navigation arrow repeatedly until the corresponding function is displayed.

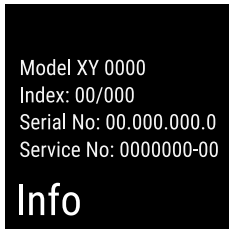

Fig. 93

- ▷ The appliance information appears.



5.3.16 Operating hours

The display shows the appliance operating hours.

Displaying operating hours

- ▶ Open customer menu .

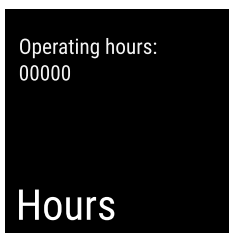

Fig. 94

- ▷ The operating hours appear.



5.3.17 Software

The display shows the software version of the appliance.

Displaying software version

- ▶ Open customer menu .
- ▶ Tap the navigation arrow repeatedly until the corresponding function is displayed.

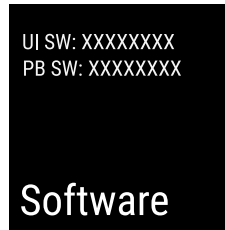

Fig. 95

- ▷ The software version is shown.



5.3.18 Sensor calibration

The sensor calibration is used to realign differences between the displayed temperature and the actual temperature in the appliance.

Setting range: +/- 3 Kelvin in 0.1 Kelvin increments.

Calibrating the sensor

- ▶ Call up settings menu. (see 5.2 Navigation)
- ▶ Tap navigation arrow repeatedly until corresponding function is displayed.

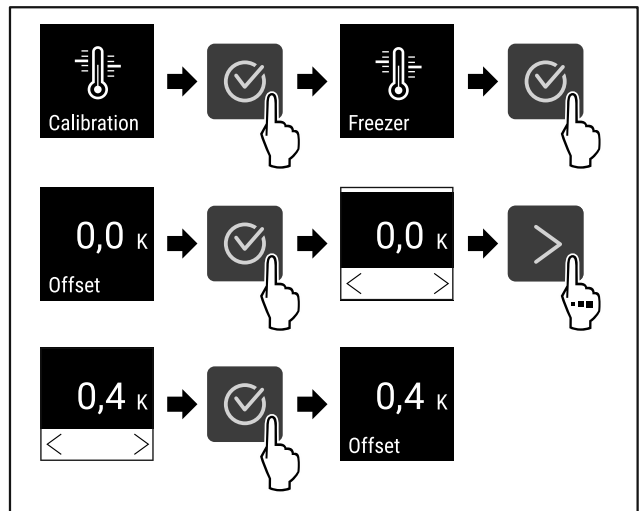

Fig. 96

- ▶ Complete steps (see Fig. 96).
- ▷ The sensor is calibrated.



5.3.19 Temperature alarm

The temperature alarm is triggered as soon as the interior temperature differs from the adjustable temperature range and any set delay time has elapsed.

The following values can be set:

- Lower temperature limit in 0.1 °C increments
- Upper temperature limit in 0.1 °C increments
- Alarm delay time of between 0 and 60 minutes
- Alarm repetition frequency of between 0 and 30 minutes

Setting temperature alarm

- ▶ Call up settings menu. (see 5.2 Navigation)
- ▶ Tap navigation arrow repeatedly until corresponding function is displayed.

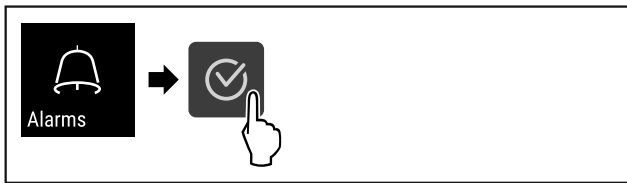

Fig. 97

- ▶ Complete steps (see Fig. 97).
- ▶ Tap navigation arrow repeatedly until corresponding function is displayed.

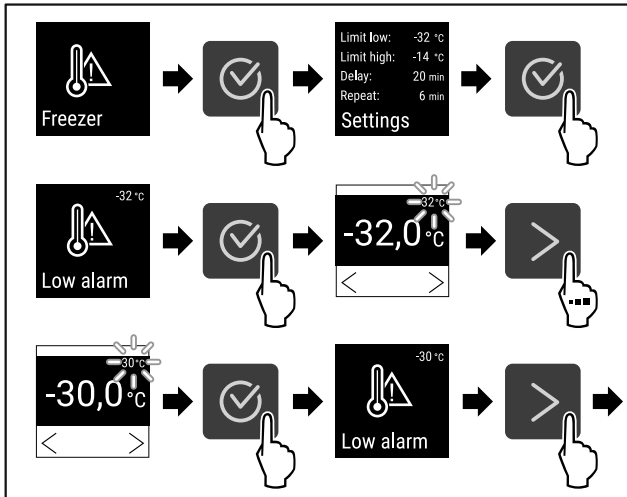

Fig. 98

- ▶ Complete steps (see Fig. 98).
- ▷ Lower temperature limit has been set.

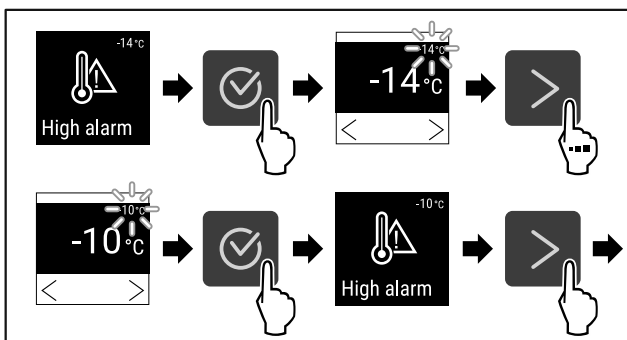

Fig. 99

- ▶ Complete steps (see Fig. 99).
- ▷ Upper temperature limit has been set.

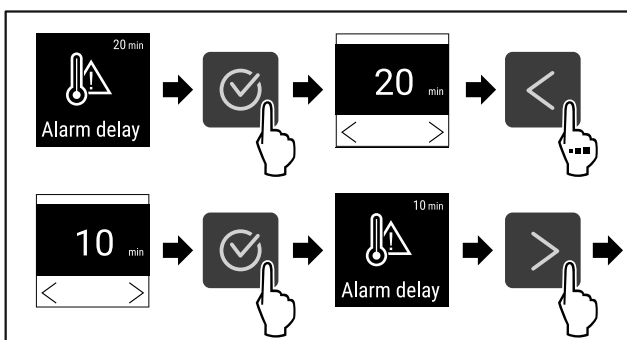

Fig. 100

- ▶ Complete steps (see Fig. 100).
- ▷ Alarm delay time has been set.

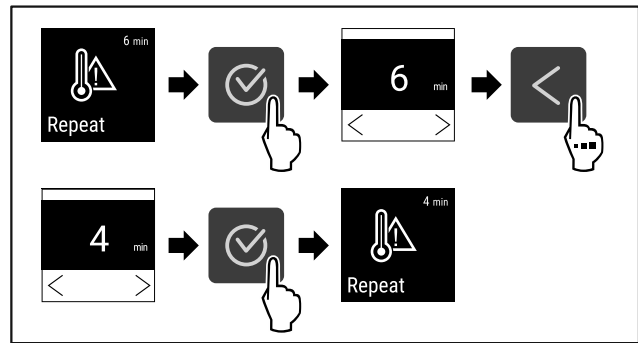

Fig. 101

- ▶ Complete steps (see Fig. 101).
- ▷ Alarm repetition interval has been set.
- ▷ Temperature alarm has been set.

Displaying set temperature alarm values

- ▶ Open settings menu (see 5.2 Navigation).
- ▶ Tap navigation arrow repeatedly until corresponding function is displayed.

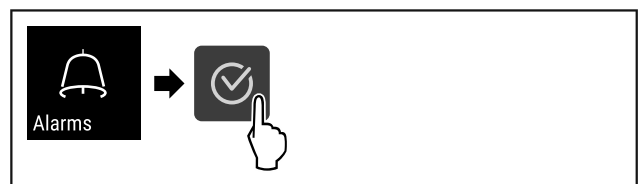

Fig. 102

- ▶ Complete steps (see Fig. 97).
- ▶ Tap navigation arrow repeatedly until corresponding function is displayed.

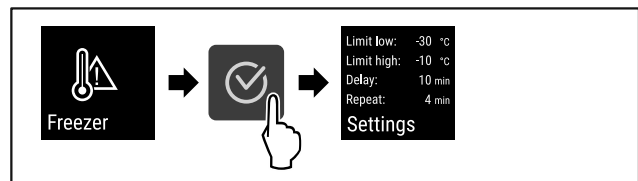

Fig. 103

- ▶ Complete steps (see Fig. 103).
- ▷ Set temperature alarm values are displayed.



5.3.20 Door alarm

Setting the time interval after which the door alarm sounds when the door is opened.

The following values can be set:

- 15 seconds
- 30 seconds
- 60 seconds
- 90 seconds
- 120 seconds
- 150 seconds
- 180 seconds
- Off

Setting door alarm

The following steps describe how you set the time interval before the door alarm sounds.

- ▶ Open settings menu (see 5.2 Navigation).
- ▶ Tap the navigation arrow repeatedly until the corresponding function is displayed.

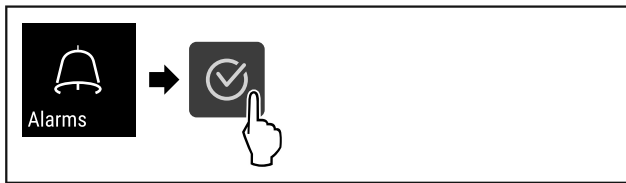

Fig. 104

- ▶ Complete steps (see Fig. 104).
- ▶ Tap the navigation arrow repeatedly until the corresponding function is displayed.

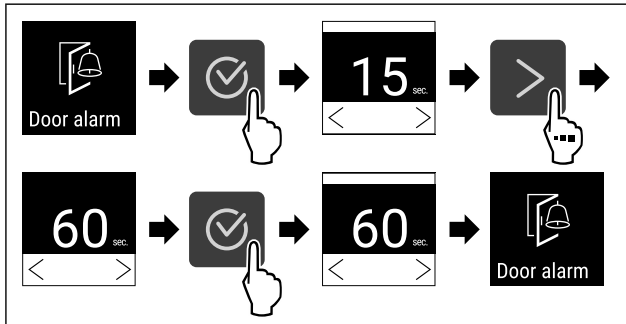

Fig. 105

- ▶ Complete steps (see Fig. 105).
- ▷ The door alarm is set.

Deactivating door alarm

The following steps describe how you deactivate the door alarm.

- ▶ Open settings menu (see 5.2 Navigation).
- ▶ Tap the navigation arrow repeatedly until the corresponding function is displayed.

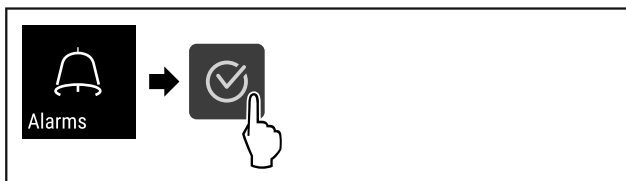

Fig. 106

- ▶ Complete steps (see Fig. 106).
- ▶ Tap the navigation arrow repeatedly until the corresponding function is displayed.

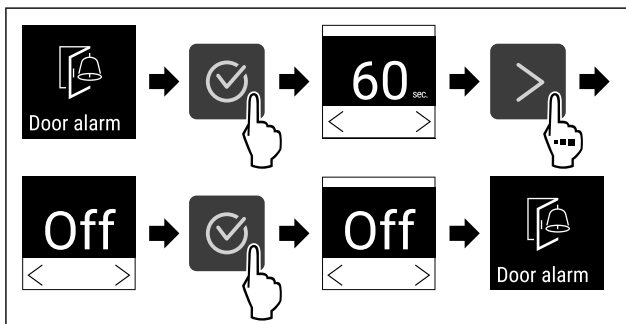

Fig. 107

- ▶ Complete steps (see Fig. 107).
- ▷ The door alarm is deactivated.

5.3.21 Alarm simulation



This setting makes it possible to simulate a change in the appliance temperature to check the function of any safety devices that may be connected.

Starting alarm simulation

- ▶ Call up settings menu. (see 5.2 Navigation)
- ▶ Tap navigation arrow repeatedly until corresponding function is displayed.

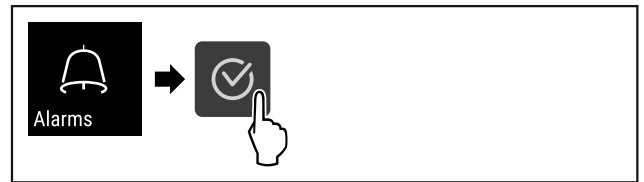

Fig. 108

- ▶ Complete steps (see Fig. 108).
- ▶ Tap navigation arrow repeatedly until corresponding function is displayed.

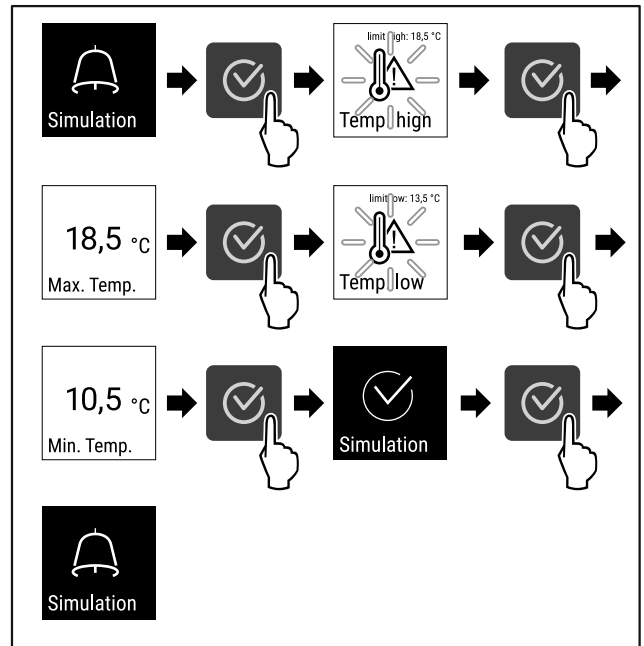

Fig. 109

- ▶ Complete steps (see Fig. 109).
- ▷ The simulation has been performed.
- ▷ Connected safety devices should have triggered.

5.3.22 Alarm relay



This setting makes it possible to relay one or more alarms to an external alarm source connected to the appliance.

The following settings can be selected:

- Alarm type:
 - Door alarm
 - Temperature alarm
 - Door alarm and temperature alarm
 - All
- Confirm:
 - **Yes:** Alarm is stopped on the appliance and on the externally connected appliance.
 - **No:** Alarm is acknowledged on the appliance and remains active on the external appliance until the error is remedied.
- Update (only visible if Yes is selected in response to Confirm):
 - **Yes:** Alarm is recurring according to the set time. (see 5.3.20 Door alarm)
 - **No:** Alarm is continuously acknowledged.

Activating alarm relay

- ▶ Call up settings menu. (see 5.2 Navigation)
- ▶ Tap navigation arrow repeatedly until corresponding function is displayed.

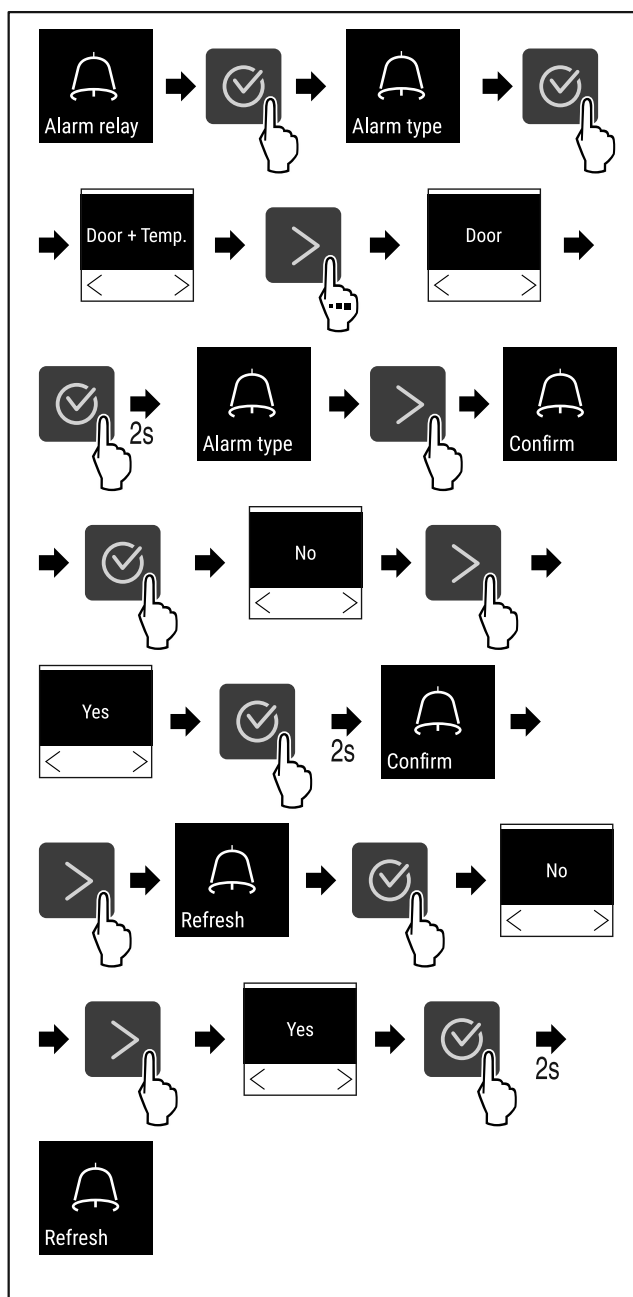

Fig. 110

- ▶ Complete steps (see Fig. 110).
- ▷ The alarm relay has been set.

5.3.23 DemoMode



Note

Activating/deactivating DemoMode is equivalent to a factory reset. (see 5.3.24 Factory reset)

If the appliance is in DemoMode, a "D" appears in the top left of the status display and all refrigeration functions are deactivated. DemoMode is appropriate for demonstrations.

Activating DemoMode

- ▶ Open customer menu .

- ▶ Tap the navigation arrow repeatedly until the corresponding function is displayed.

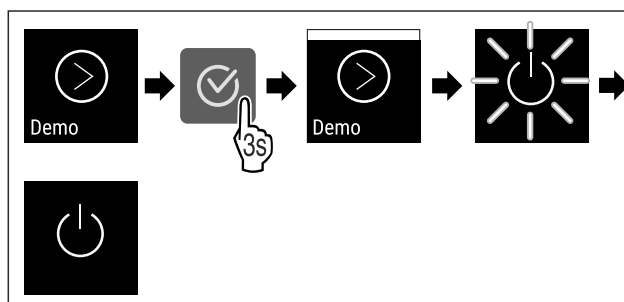

Fig. 111

- ▶ Complete steps (see Fig. 111).
- ▷ DemoMode is activated.
- ▷ Appliance is switched off.
- ▶ Restart the appliance. (see 3.16 Switching on appliance (first use))

Deactivating DemoMode

- ▶ Open customer menu .
- ▶ Tap the navigation arrow repeatedly until the corresponding function is displayed.

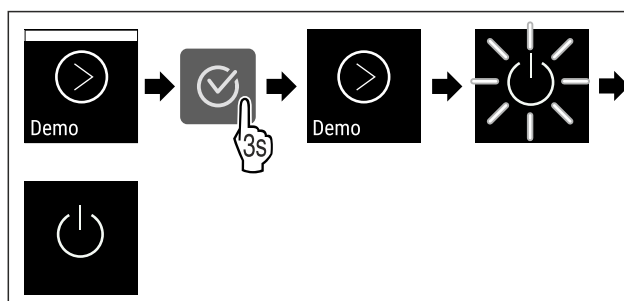

Fig. 112

- ▶ Complete steps (see Fig. 112).
- ▷ DemoMode is deactivated.
- ▷ Appliance is switched off.
- ▶ Restart the appliance. (see 3.16 Switching on appliance (first use))

5.3.24 Factory reset



This function resets the appliance to the factory settings. All settings made to this point are reset to their original values.

Performing factory reset

- ▶ Call up customer menu.
- ▶ Tap the navigation arrow repeatedly until the corresponding function is displayed.

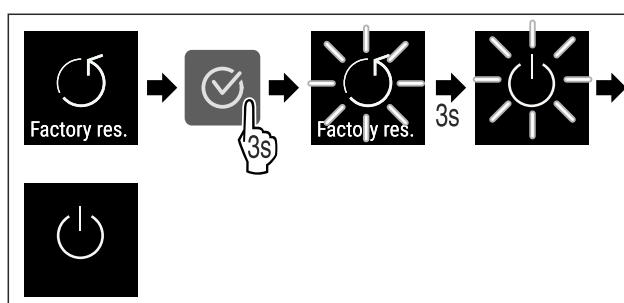

Fig. 113

- ▶ Complete the steps (see Fig. 113).
- ▷ Factory reset completed.
- ▷ Appliance is switched off.





Controls





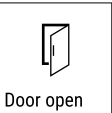

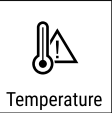

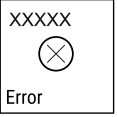

- ▶ Restart the appliance. (see 3.16 Switching on appliance (first use))

5.4 Messages

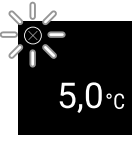





5.4.1 Warnings

Warnings are issued by means of an audio signal and visually via a symbol on the display. The signal gets louder until the warning is acknowledged.

Message	Cause	Remedy
 <p>Door open</p> <p>Door open</p>	<p>This message appears if the door is open for too long.</p>	<ul style="list-style-type: none"> ▶ Close door.  <ul style="list-style-type: none"> ▶ Press confirmation button. ▶ Alarm is stopped. <p>Note</p> <p>You can set how long it takes for this message to appear (see 5.3.20 Door alarm).</p>
 <p>Temperature</p> <p>Temperature alarm</p>	<p>This message appears if the temperature does not match the set temperature. Reasons for the differences in temperature can be:</p> <ul style="list-style-type: none"> - Warm items for refrigeration have been placed inside. - Too much warm room air flowed in when rearranging and removing refrigerated products. <p>The power was cut off for a prolonged period.</p>	 <ul style="list-style-type: none"> ▶ Press confirmation button. ▶ The highest temperature is shown.  <ul style="list-style-type: none"> ▶ Press confirmation button. ▶ The current temperature flashes and display switches to the temperature alarm symbol until the set temperature is reached. ▶ Check quality of refrigerated items.

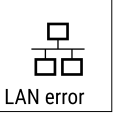

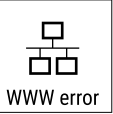

Message	Cause	Remedy
 <p>Error</p> <p>Error</p>	<p>The appliance is faulty, there is an appliance error or a component of the appliance has a fault.</p>	<ul style="list-style-type: none"> ▶ Store the refrigerated items elsewhere.  <ul style="list-style-type: none"> ▶ Press confirmation button. <ul style="list-style-type: none"> ▶ Error code is displayed.   <ul style="list-style-type: none"> ▶ Press confirmation button. ▶ A further error code is displayed if there is one. <p>Or</p> <ul style="list-style-type: none"> ▶ Status screen is displayed with flashing  <p>arrow symbol</p> <ul style="list-style-type: none"> ▶ Pressing the navigation buttons displays error code(s) again. ▶ Make a note of error code(s) and contact Customer Service.
 <p>Power</p> <p>Power cut</p>	<p>The message appears after an interruption to the power supply if the temperature is above the alarm limit when the power returns.</p>	 <ul style="list-style-type: none"> ▶ Press confirmation button. <p>Highest temperature and number of electricity supply interruptions are displayed.</p>  <ul style="list-style-type: none"> ▶ Press confirmation button. ▶ Alarm is stopped and current temperature is displayed. ▶ Check quality of refrigerated items.
 <p>WiFi error</p> <p>WiFi error</p>	<p>WiFi connection is interrupted.</p>	<ul style="list-style-type: none"> ▶ Check connection.  <ul style="list-style-type: none"> ▶ Press confirmation button. ▶ Alarm is stopped.

Features

 <p>WWW error</p> <p>WWW error, WiFi</p>	<p>This message appears if there is no internet connection via WiFi.</p>	<ul style="list-style-type: none"> ▶ Check connection.  <ul style="list-style-type: none"> ▶ Press confirmation button. ▶ Alarm is stopped.
 <p>LAN error</p> <p>LAN error</p>	<p>LAN connection is interrupted.</p>	<ul style="list-style-type: none"> ▶ Check connection and network cable.  <ul style="list-style-type: none"> ▶ Press confirmation button. ▶ Alarm is stopped.
 <p>WWW error</p> <p>WWW error, LAN</p>	<p>This message appears if there is no internet connection via LAN.</p>	<ul style="list-style-type: none"> ▶ Check connection.  <ul style="list-style-type: none"> ▶ Press confirmation button. ▶ Alarm is stopped.

5.4.2 Reminder

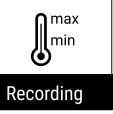
Reminders appear when you are being asked to do something. They are issued by means of an audio signal and visually via a symbol on the display. Acknowledge the message by pressing the confirmation button.

Message	Cause	Remedy
 <p>Maintenance</p> <p>Maintenance reminder</p>	<p>The message appears when the timer for the set maintenance interval has expired.</p>	 <ul style="list-style-type: none"> ▶ Press confirmation button. ▶ Alarm is stopped. <p>Note</p> <p>The maintenance interval can be set (see 5.3.7 Maintenance interval reminder).</p>
 <p>Recording</p> <p>Recording reminder</p>	<p>This message appears when the temperature recording memory (999 hours) is full.</p>	 <ul style="list-style-type: none"> ▶ Press confirmation button ▶ Alarm is stopped. ▶ The oldest data are overwritten. <p>Note</p> <p>The temperature recording can be reset (see 5.3.4 Temperature recording).</p>

6 Features

6.1 Safety lock

The lock in the appliance door is equipped with a safety mechanism.

6.1.1 Locking appliance

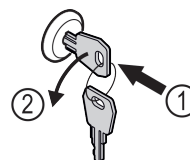

Fig. 114

- ▶ Insert key.
- ▶ Turn key anticlockwise by 90°.
- ▷ The appliance is locked.

6.1.2 Unlocking appliance

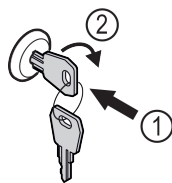

Fig. 115

- ▶ Insert key Fig. 115 (1).
- ▶ Turn key clockwise by 90° Fig. 115 (2).
- ▷ The appliance is unlocked.

6.2 Sensors

The appliance can be equipped with the following sensors for temperature monitoring:

- C sensor

6.2.1 C sensor (control sensor)

The C sensor is permanently installed and regulates the interior temperature of the appliance. You can calibrate the C sensor if necessary. (see 5.3.18 Sensor calibration)

6.3 Interfaces

There are various connection options on the back of the appliance.

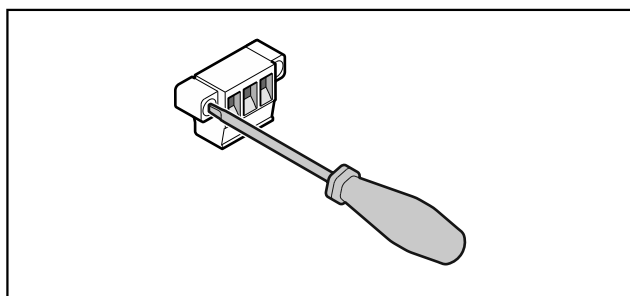

Fig. 116

Note

Screws secure the plugs. To enable disconnection of the plugs, loosen the screws on the left and right.

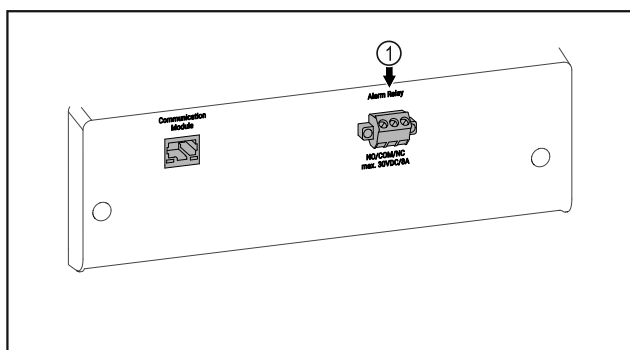

Fig. 117

- (1) Potential-free alarm output

6.3.1 Potential-free alarm output



WARNING

Risk of injury due to electric shock!

- ▶ The appliance may only be connected to an external alarm device by trained specialist personnel.

These three contacts can be used to connect a visual or an acoustic alarm device. The connection is designed for a maximum of **30 V (DC) - 8 A** from a safety low voltage source SELV (**minimum current 150 mA**).

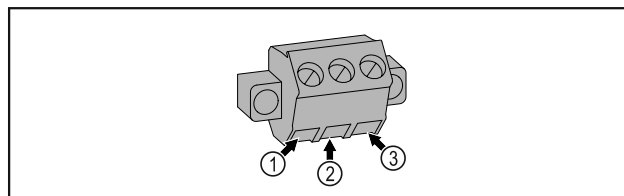

Fig. 118

- (1) NO (normally open)
Connection for indicator lamp, which is active in normal operation or when the appliance is switched off.
- (2) COM (common)
External voltage source
- (3) NC (normally closed)
Connection for alarm lamp or audible alarms, which is active when an alarm is triggered or there is a lack of power supply.

7 Maintenance

7.1 Maintenance schedule

Maintenance work is to be performed at regular intervals to ensure proper appliance function.



CAUTION

Danger of injury and damage due to unprofessional maintenance work!

Personal injury and material damage.

- ▶ Maintenance work may only be performed by trained specialist personnel.



WARNING

Short-circuit hazard due to live parts!

Electric shock or damage to the electronics.

- ▶ **Switch off the appliance.**
- ▶ Pull out mains plug or switch off fuse.

Note

A maintenance reminder function can be activated. (see 5.3.7 Maintenance interval reminder)

Note

We recommend creating a maintenance log in which all work (repairs, checks) performed is documented.

Note

Liebherr recommends yearly maintenance. For an individual offer, please contact Customer Service (see 8.3 Customer Service).

Maintenance

Component	Activity	Maintenance interval
Sheet metal parts	Check for damage and corrosion. Replace damaged parts: (see 8.3 Customer Service)	Yearly
Door, hinges	Check alignment (see 3.14 Aligning the door) , ease of movement, and tight fit.	Yearly
Lock, door handle	Check for ease of movement and tight fit.	Yearly
Door seal	Check for damage, wear, and tight fit. A replacement door seal is available via Customer Service (see 8.3 Customer Service) .	Yearly
Sensor	Calibrate sensor. (see 5.3.18 Sensor calibration)	Yearly
Sensor feedthrough	Check that the sealing compound is intact.	Yearly
Surfaces	Cleaning (see 7.3 Cleaning the appliance)	Recommendation: monthly or as required/specified at installation location
Surfaces	Disinfection	Recommendation: monthly or as required/specified at installation location
Installation location, appliance	Decontamination The appliance is suitable for room decontamination with hydrogen peroxide H ₂ O ₂ . In this context, the values of the following application specifications must not be exceeded: Concentration: maximum 250 ppm. Humidity: maximum 85%. Maximum permissible room temperature as per climate class. (see 1.4 Range of use of appliance)	Recommendation: as required/specified at installation location, maximum 2x per year
Fan air slots	Cleaning	Yearly
Alarm relay		
Mains cable	Check for damage.	Yearly or if there is a change of location
Tilt angle	Check for proper function and tight fit.	Yearly or if there is a change of location
Adjusting feet/castors	Check for proper function, damage, and tight fit. Replace damaged parts. (see 8.3 Customer Service)	Yearly
Defrost water collection tray	Check the fill level of the defrost water collection tray and empty if necessary.	Regular visual inspection

7.2 Defrosting appliance



WARNING

Improper defrosting of the appliance!
Injuries and damage.

- ▶ Do not use mechanical equipment or other methods to speed up the defrosting process other than those recommended by the manufacturer.
- ▶ Do not use electrical heating or steam-cleaning appliances, naked flames or defroster sprays to defrost.
- ▶ Do not use sharp objects to remove ice.

To ensure the appliance remains energy efficient, we recommend defrosting it at regular intervals or if there is a large buildup of ice. The main factors causing ice to form inside your appliance are its location (e.g. high humidity), the settings on the appliance and user behaviour.

Manual defrosting:

- ▶ Switch off appliance. (see 5.3.2 Switching appliance on and off)
- ▶ Pull out mains plug.
- ▶ Store refrigerated items elsewhere.
- ▶ Leave appliance door open during defrosting process.
- ▶ Absorb any remaining defrost water with a cloth and clean the appliance.

7.3 Cleaning the appliance

7.3.1 Preparing



WARNING

Short-circuit hazard due to live parts!
Electric shock or damage to the electronics.

- ▶ **Switch off the appliance.**
- ▶ Pull out mains plug or switch off fuse.



WARNING

Risk of fire

- ▶ Do not damage the refrigeration circuit.

- ▶ Empty the appliance.
- ▶ Pull out the mains plug.

7.3.2 Cleaning housing

NOTICE

Improper cleaning!

Damage to the appliance.

- ▶ Only use soft cleaning cloths and ph-neutral all-purpose cleaners.
- ▶ Do not use abrasive sponges or steel wool which may cause scratches.
- ▶ Do not use any sharp or abrasive cleaning agents, nor any that contain sand, chloride or acid.



WARNING

Risk of injury and damage as a result of hot steam!

Hot steam can lead to burns and can damage the surfaces.

- ▶ Do not use any steam cleaners!

NOTICE

Risk of damage due to short circuit.

- ▶ When cleaning the appliance, make sure no water gets into the electrical components.
- ▶ Wipe the housing down with soft, clean cloth. If very dirty, use lukewarm water with a neutral cleaner. Glass surfaces can also be cleaned with glass cleaner.
- ▶ Clean condenser coil each year. If the condenser coil is not cleaned, this significantly reduces the efficiency of the appliance.

7.3.3 Cleaning interior



WARNING

Short-circuit hazard due to live parts!

Electric shock or damage to the electronics.

- ▶ **Switch off the appliance.**
- ▶ Pull out mains plug or switch off fuse.

Temperature range	
Freezing	-9 °C to -30 °C

Maximum load per shelf ^{A)}			
Appliance width (see 3.2 Appliance dimensions)	Grid shelf	Glass shelf	Wooden shelf
600 mm	45 kg	40 kg	45 kg
750 mm	60 kg	40 kg	60 kg

A) Heavier loads may result in a slight bending of the shelves.

Maximum total load and net weight		
Model (see 3.2 Appliance dimensions)	Maximum total load	Net weight
SFF.. 4001	270 kg	76 kg
SFFfg 5501	300 kg	100 kg

Maximum net capacity
See net capacity on the type plate. (see 1.2 Overview of appliance and equipment)



WARNING

Risk of injury and damage as a result of hot steam!

Hot steam can lead to burns and can damage the surfaces.

- ▶ Do not use any steam cleaners!

NOTICE

Improper cleaning!

Damage to the appliance.

- ▶ Only use soft cleaning cloths and ph-neutral all-purpose cleaners.
- ▶ Do not use abrasive sponges or steel wool which may cause scratches.
- ▶ Do not use any sharp or abrasive cleaning agents, nor any that contain sand, chloride or acid.

Note

Do not damage or remove the type plate on the inside of the appliance. The type plate is important for Customer Service. (see 8.3 Customer Service)

- ▶ Open the door.
- ▶ Empty the appliance.
- ▶ Clean interior and equipment parts with lukewarm water and a little detergent. Do not use any gritty or acidic cleaning agent or any chemical solvent.

7.3.4 After cleaning

- ▶ Wipe appliance and equipment parts dry.
- ▶ Connect and switch on appliance. Once the temperature is sufficiently cold:
 - ▶ put in items for refrigeration goods.
 - ▶ Repeat cleaning regularly.
- ▶ Clean and dust refrigerators with a heat exchanger (metal grille on the rear of the appliance) once per year.

8 Customer help

8.1 Technical specifications

Customer help

Set-up conditions	
Degrees of pollution (surrounding the appliance)	PD2
Ambient temperature	+10 °C to +35 °C
Maximum relative ambient moisture	75%, not condensing
Maximum operating elevation (metres above sea level)	2000 m / 1500 m (glass door)

Electrical values	
Nominal voltage	220-240 V ~
Frequency	50 Hz
Connected load	2,0 A
Maximum mains fluctuation	+/-10%
Overvoltage categories	II

8.2 Technical fault

Your appliance is designed and built to ensure it works reliably and has a long service life. In the unlikely event that a fault occurs during operation, please check whether the fault is due to an operating error. If this is the case, you will

be charged for the cost incurred even if this falls within the warranty period.

You can fix the following faults yourself.

8.2.1 Appliance function

Defect	Cause	Remedy
The appliance is not working.	→ The appliance is not switched on.	▶ Switch on the appliance.
	→ The mains plug is not properly plugged into the socket.	▶ Check the mains plug.
	→ There is something wrong with the fuse in the socket.	▶ Check fuse.
	→ Power cut	▶ Keep the appliance closed. ▶ If necessary move the refrigerated/frozen items to another fridge or freezer if the power is off for a prolonged period.
	→ The appliance plug is not properly inserted in the appliance.	▶ Check appliance plug.
Temperature is not cold enough.	→ The appliance door is not closed properly.	▶ Close appliance door.
	→ Ventilation is not sufficient.	▶ Clear ventilation grille and clean it.
	→ The ambient temperature is too high.	▶ Ensure the correct ambient conditions: (see 1.4 Range of use of appliance)
	→ The appliance was opened too many times or for too long.	▶ Wait to see if the required temperature corrects itself. If not, contact Customer Service (see 8.3 Customer Service).
	→ The temperature is set incorrectly.	▶ Set a colder temperature and check after 24 hours.
	→ The appliance is too close to a heat source (oven, radiator, etc).	▶ Change where the appliance or the heat source are located.

8.3 Customer Service

First check whether you can remedy the fault yourself. If this is not the case, please contact Customer Service.

Please refer to the enclosed "Liebherr-Service" brochure for the address.



WARNING

Unprofessional repair!

Injuries.

- ▶ Have any repairs and action - not expressly specified - on the appliance and mains cable carried out by service personnel only. (see 7 Maintenance)
- ▶ A damaged mains cable may only be replaced by the manufacturer, the manufacturer's Customer Service or a similarly qualified person.
- ▶ In the case of appliances with an IEC connector, the change may be made by the customer.

8.3.1 Contacting Customer Service

Make sure you have the following appliance data at the ready:

- Appliance name (model and index)
- Service no. (Service)
- Serial no. (S no.)
- ▶ Access the appliance information via the display (see 5.3.15 Info).
- or-
- ▶ Refer to the type plate for appliance information. (see 8.4 Type plate)
- ▶ Note down appliance information.
- ▶ Inform Customer Service: Report faults and the appliance information.
- ▷ This will help us to provide a fast and focussed service.
- ▶ Follow any further instructions provided by Customer Service.

8.4 Type plate

The type plate is inside the appliance. See appliance overview.

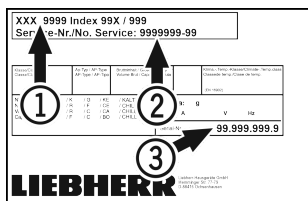

Fig. 119

- (1) Appliance designation (3) Serial No.
(2) Service No.

9 Shutting down

- ▶ Empty the appliance.
- ▶ Switch off the appliance.
- ▶ Pull out the mains plug.
- ▶ Remove appliance connector if required: remove and at the same time move from left to right.
- ▶ Clean appliance (see 7.3 Cleaning the appliance) .
- ▶ Leave the door open so that no bad odours form.

Note

Damage to the appliance and malfunctions!

- ▶ After shutting down, only store the appliance at the permitted room temperature of between -10 °C and +50 °C.

10 Disposal

10.1 Preparing appliance for disposal



Liebherr uses batteries in some of its appliances. In the EU, for environmental reasons, legislation obliges the end user to remove these batteries before disposing of old appliances. If your appliance contains batteries, a corresponding notice is attached.

Lamps If you can remove the lamps yourself without destroying them, also remove these before disposal.

- ▶ Take the appliance out of operation.
- ▶ Appliances with batteries: remove the batteries. For description, see **Maintenance** chapter.

- ▶ If possible: remove lamps without destroying them.

10.2 Disposing of the appliance in an environmentally friendly manner



The appliance still contains valuable materials and must be disposed of separately from unsorted municipal waste.



Dispose of batteries separately from the old appliance. To do this, you can return the batteries free of charge to retailers as well as recycling centres and collection centres for recyclable materials.

Lamps

Dispose of removed lamps via the respective collection systems.

For Germany:

You can dispose of the appliance free of charge via the class 1 collection containers at the local recycling and recyclable material collection centres. When purchasing a new fridge/freezer, if the sales area > 400 m², retailers will also take back the old appliance free of charge.



WARNING

Leaking coolant and oil!

Fire. The coolant contained in the appliance is eco-friendly, but also flammable. The oil contained in the appliance is flammable. Escaping coolant and oil can ignite if the concentration is high enough and in contact with an external heat source.

- ▶ Do not damage the pipelines of the coolant circuit and the compressor.

- ▶ Transport the appliance without damaging it.
- ▶ Dispose of batteries, lamps and the appliance according to the above specifications.

11 Additional information

Further information on warranty conditions can be found in the enclosed service brochure or on the Internet at <https://home.liebherr.com>.

If appliance malfunctions, inform: _____

Model ID / Inventory number: _____

Quick Start Guide for everyday use

Information about using this Quick Start Guide:

- This Quick Start Guide is not a substitute for the full operating instructions nor is it a substitute for appliance training.
- This Quick Start Guide provides support for everyday use and handling the appliance.
- Read the full operating instructions and the safety notes contained therein.

This quick start guide is for: SFFfg 40../55..



Scanning the QR code will open the full operating instructions:



Intended use

This laboratory freezer, with an interior free of ignition sources, is suitable for professional storage of highly flammable products in closed containers, at temperatures between -9 °C and -30 °C.

Foreseeable incorrect use

Do not use the appliance for the following applications:

- Storage and refrigeration of:
 - Chemically unstable substances
 - Blood, plasma or other body fluids for the purpose of infusion, application or introduction in the human body
- Use in potentially explosive atmospheres
- Use outdoors or in areas exposed to dampness and splashing water

When stocking, observe the following points:

- Position grid shelves according to the height required.
- Observe maximum load.
- When the storage temperature has been reached, load the appliance (compliance with cold chain).
- Produce for cooling must not come into contact with the evaporator on the rear wall.
- Keep liquids in closed containers.
- Leave space when storing refrigerated goods to ensure good air circulation.

Status display



Fig. 120 Status display with actual temperature

Navigating using buttons

Display and button	Description
	Forwards navigation arrow Advances one menu (submenu). The first menu appears again after the last menu.
	Backwards navigation arrow Short press: goes back one menu (submenu). Long press (3 seconds): returns to the status display.
	Confirm Activates/deactivates function. Opens submenu. Confirms selection. The display switches back to the menu.
	Back Jumps back one level.

Displaying temperature recording

The temperature recording displays the length of the recording and the minimum and maximum temperatures measured during this period of time.

- Press navigation arrow repeatedly until corresponding functions are displayed.



Fig. 121

Resetting temperature recording

- Press navigation arrow repeatedly until corresponding functions are displayed.

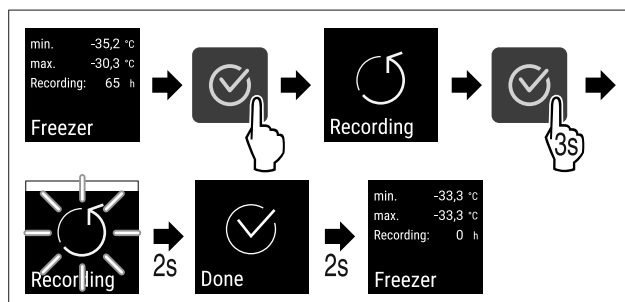

Fig. 122

- Carry out steps according to the illustration.

Quick Start Guide for everyday use

Unlocking appliance

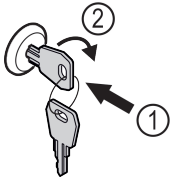

Fig. 123

- ▶ Insert the key. Fig. 123 (1)
- ▶ Turn the key clockwise by 90°. Fig. 123 (2)
- ▷ The appliance is unlocked.

Locking appliance

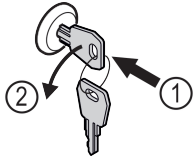

Fig. 124

- ▶ Insert the key. Fig. 124 (1)
- ▶ Turn the key anticlockwise by 90°. Fig. 124 (2)
- ▷ The appliance is locked.

Cleaning appliance

- ▶ Empty the appliance.
- ▶ Pull out the mains plug.
- ▶ Observe the information in the operating instructions.
- ▶ Dry the appliance and equipment thoroughly after cleaning.
- ▶ Connect the appliance.
- ▶ Switch on the appliance.
- ▶ Load the appliance once the storage temperature is reached.



What should I do if there is a fault?

A message appears in the display if there is a fault. Messages have different meanings:

Symbol colour in the display	Meaning	Remedy
WHITE with black bar	Reminder Reminder of general procedures. You can carry out these procedures to eliminate the message.	Consult the operating instructions and perform the troubleshooting steps.
WHITE	Warning Appears when there are malfunctions. You can eliminate simple malfunctions yourself.	Consult the operating instructions and perform the troubleshooting steps.

If you cannot remedy the fault yourself, contact a competent member of staff or your nearest customer service outlet.

Cut out the page



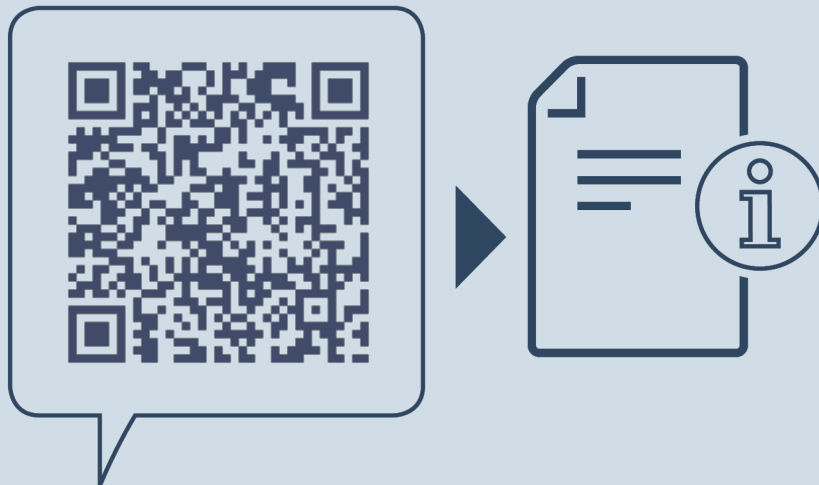

home.liebherr.com/fridge-manuals

EN Freezer
ORIGINAL OPERATOR'S MANUAL

Issue date: 20230601

Part number index: 7080746-00

Liebherr Hausgeräte Lienz GmbH
Dr.-Hans-Liebherr-Strasse 1
A-9900 Lienz
Österreich

