

TANGO NEXT

ISTRUZIONI D'USO PER L'UTENTE

*LEGGERE ATTENTAMENTE E CONSERVARE CON CURA
ASSIEME AL MOBILE*

INSTRUCTIONS

POURL'UTILISATEUR

*LIRE AVEC ATTENTION CE MANUEL ET LE
CONSERVERPRÈS DU MEUBLE AVEC SOIN*

USER INSTRUCTIONS

READ CAREFULLY AND KEEP WITH THE CABINET

BETRIEBSANLEITUNGFÜR

BETREIBER

*SORGFÄLTIG LESEN UND MIT DEM MÖBEL
AUFBEWAHREN*

INSTRUCCIONES DE USO PARA EL USUARIO

*LEER ATENTAMENTE Y CONSERVARCON ESMERO
JUNTO AL MUEBLE*

INSTRUÇÕES PARA O USO

*LER COM ATENÇÃO E GUARDAR COM CUIDADO JUNTO
AO MÓVEL*

AD INTERESSARE IL CICLO DI RAFFREDDAMENTO O L'IMPIANTO ELETTRICO DEVONO ESSERE ESEGUITE ESCLUSIVAMENTE DA PERSONALE QUALIFICATO E PRIMA DI OGNI INTERVENTO SI DEVE SCOLLEGARE LA SPINA DEL BANCO DALLA PRESA ELETTRICA DI ALIMENTAZIONE.

NON DANNEGGIARE IL CIRCUITO REFRIGERANTE: E' VIETATO FORARE IN QUALSIASI MODO LE PARETI DEL MOBILE SIA INTERNE CHE ESTERNE (PER ESEMPIO PER APPLICARE UN'ALZATA). NEL CASO SI VOGLIA APPLICARE SUL MOBILE DELLE ETICHETTE ADESIVE PUBBLICITARIE, FARE USO ESCLUSIVAMENTE DI FOGLI SOTTILI, NON APPLICARE SULLE PARETI ESTERNE DEL MOBILE MATERIALE SPESSI ED ISOLANTI: CIO' COMPROMETEREBBE LE PRESTAZIONI DEL MOBILE.

OGNI ALTRO USO NON ESPLICITAMENTE INDICATO IN QUESTO MANUALE E' DA CONSIDERARSI PERICOLOSO ED IL COSTRUTTORE NON PUO' ESSERE RITENUTO RESPONSABILE PER EVENTUALI DANNI DERIVANTI DA USO IMPROPRIO, ERRONEO ED IRRAGIONEVOLE.

SAFETY ADVICE FOR EQUIPMENT USING R290 (PROPANE)

PROPANE IS A NATURAL GAS WITH NO EFFECTS ON THE ENVIRONMENT, BUT IT IS FLAMMABLE. BEFORE CONNECTING THE EQUIPMENT UP TO THE SUPPLY LINE, IT IS THEREFORE MANDATORY TO ENSURE THAT ALL THE PIPEWORK IN THE REFRIGERATING CIRCUIT ARE NOT DAMAGED. THE INSTALLATION ROOM MUST HAVE A MINIMUM VOLUME OF 1M³ EVERY 8 GR OF REFRIGERANT. THE AMOUNT OF REFRIGERANT USED BY THE EQUIPMENT IS INDICATED ON THE RATING PLATE OF THE EQUIPMENT. IN CASE OF A REFRIGERANT LEAK, AVOID FREE FLAMES AND SOURCES OF IGNITION. DO NOT DAMAGE THE PIPEWORK IN THE REFRIGERATING CIRCUIT.

CAUTION! DO NOT DAMAGE THE PIPEWORK IN THE REFRIGERATING CIRCUIT.

CAUTION! AVOID FLAMES AND SPARKS INSIDE THE EQUIPMENT.

CAUTION! KEEP THE AIR SLOTS ON THE EQUIPMENT'S ENCLOSURE FREE FROM OBSTRUCTION.

CAUTION! DO NOT USE ELECTRICAL IMPLEMENTS INSIDE THE EQUIPMENT'S COMPARTMENTS WHERE FROZEN FOODS WILL BE STORED, UNLESS THIS IS RECOMMENDED BY THE MANUFACTURER OF THE REFRIGERATING EQUIPMENT.

CAUTION! DO NOT STORE EXPLOSIVES OR HAZARDOUS SUBSTANCES IN THE EQUIPMENT, E.G. CONTAINERS PRESSURISED WITH FLAMMABLE PROPELLENT.

CAUTION! DO NOT USE TOOLS OR MEANS OTHER THAN THOSE RECOMMENDED BY THE MANUFACTURER TO SPEED UP DEFROSTING.

SAFETY ADVICE

KEEPING PHARMACEUTICALS, GLASS BOTTLES OR FLASKS IN THE CABINET IS STRICTLY FORBIDDEN AS THEY COULD BREAK AND ENTAIL A SAFETY HAZARD.

ONLY QUALIFIED PERSONNEL IS AUTHORISED TO REMOVE PANELS OR GUARDS - ESPECIALLY THE ELECTRIC PANEL COVER - WHEN THE USE OF TOOLS IS REQUIRED.

DO NOT EXPOSE THE EQUIPMENT TO ATMOSPHERIC AGENTS.

DO NOT USE DIRECT OR INDIRECT WATER JETS ON THE CABINET. DO NOT TOUCH THE EQUIPMENT WITH DAMP OR WET HANDS OR FEET; DO NOT OPERATE IT WHILE BAREFOOT.

THE EQUIPMENT IS NOT INTENDED FOR USE BY PERSONS HAVING IMPAIRED PHYSICAL, SENSORY OR MENTAL CAPABILITIES (CHILDREN INCLUDED), OR BY PERSONS HAVING POOR EXPERIENCE OR KNOWLEDGE, UNLESS THEY ARE ASSISTED BY SOMEBODY IN CHARGE OF THEIR SAFETY OR BY SPECIFIC INSTRUCTIONS FOR THE USE OF THE EQUIPMENT. SURVEILLANCE MUST BE EXERCISED ON CHILDREN IN ORDER FOR THEM NOT TO PLAY WITH THE EQUIPMENT.

THE POWER CORDS MUST BE SPREAD OUT, SAFE FROM SHOCKS, FAR FROM LIQUIDS, WATER AND HEAT SOURCES AND THEY MUST BE IN PERFECT CONDITION. THE USE OF ADAPTOR PLUGS IS FORBIDDEN.

ENSURE THAT THE AVAILABLE MAINS VOLTAGE MEETS THE DETAILS ON THE RATING PLATE OF THE CABINET. THE CABINET MUST BE PROPERLY CONNECTED TO THE EARTHING SYSTEM. JOBS INVOLVING THE COOLING CYCLE OR THE WIRING SYSTEM MAY ONLY BE PERFORMED BY QUALIFIED PERSONNEL. BEFORE ANY SERVICING, ALWAYS DISCONNECT THE PLUG OF THE CABINET FROM THE MAINS OUTLET.

DO NOT DAMAGE THE REFRIGERATION CIRCUIT: IT IS FORBIDDEN TO PIERCE THE CABINET WALLS, WHETHER INTERNAL OR EXTERNAL, (E.G. TO INSTALL A TOP). IF ADVERTISING STICKERS NEED TO BE AFFIXED ONTO THE CABINET, ONLY USE THIN FOIL STICKERS. DO NOT LAY THICK INSULATING MATERIAL ON THE EXTERNAL WALLS OF THE EQUIPMENT: THIS COULD COMPROMISE CABINET PERFORMANCE.

USES OTHER THAN EXPLICITLY INDICATED IN THIS BOOKLET MUST BE CONSIDERED AS HAZARDOUS. THE MANUFACTURER DISCLAIMS ALL LIABILITY FOR DAMAGE RESULTING FROM IMPROPER, INCORRECT OR UNREASONABLE USE.

AVERTISSEMENTS POUR LES APPAREILS QUI UTILISENT DU R290 (PROPANE)

LE PROPANE EST UN GAZ NATUREL SANS EFFET SUR L'ENVIRONNEMENT, MAIS IL EST INFLAMMABLE. IL EST DONC INDISPENSABLE DE S'ASSURER QU'AUCUN TUYAU DU CIRCUIT RÉFRIGÉRANT N'EST ENDOMMAGÉ, AVANT DE BRANCHER L'APPAREIL AU RÉSEAU D'ALIMENTATION. POUR CHAQUE QUANTITÉ DE 8 GR DE RÉFRIGÉRANT, LE LOCAL D'INSTALLATION DOIT DISPOSER D'UN VOLUME MINIMUM DE 1M³. LA QUANTITÉ DE RÉFRIGÉRANT DANS L'APPAREIL EST INDIQUÉE SUR LA PLAQUETTE DE DONNÉES TECHNIQUES PLACÉE SUR L'APPAREIL. EN CAS DE FUITE DE RÉFRIGÉRANT, ÉVITER QUE DES FLAMMES LIBRES OU DES SOURCES D'ALLUMAGE NE SE TROUVENT À PROXIMITÉ DU POINT DE FUITE. FAIRE ATTENTION DE NE PAS ENDOMMAGER LES TUYAUTERIES DU CIRCUIT RÉFRIGÉRANT.

ATTENTION! ÉVITER LES FEUX OU LES ÉTINCELLES À L'INTÉRIEUR DE L'APPAREIL.

ATTENTION! MAINTENIR LES OUVERTURES DE VENTILATION BIEN DÉGAGÉES DANS LE BOITIER DE L'APPAREIL.

ATTENTION! NE PAS UTILISER D'APPAREILS ÉLECTRIQUES A L'INTÉRIEUR DES COMPARTIMENTS POUR LA CONSERVATION DES ALIMENTS CONGELÉS PAR L'APPAREIL, SI CEUX-CI NE SONT PAS DU TYPE RECOMMANDÉ PAR LE CONSTRUCTEUR.

ATTENTION! NE PAS CONSERVER À L'INTÉRIEUR DE CET APPAREIL DES SUBSTANCES EXPLOSIVES OU DANGEREUSES COMME DES RÉCIPIENTS SOUS PRESSION AVEC DU GAZ PROPULSEUR INFLAMMABLE

ATTENTION! NE PAS UTILISER DE DISPOSITIFS MÉCANIQUES OU AUTRES MOYENS POUR ACCÉLÉRER LE PROCESSUS DE DÉGIVRAGE DIFFÉRENTS DE CEUX QUI SONT RECOMMANDÉS PAR LE CONSTRUCTEUR.

This manual was drafted in a simple and rational manner to allow you to fully understand your equipment. You are advised to read the content carefully and keep it with the equipment. The manufacturer cannot be held in any way liable for damage caused to people or property due to non-compliance with warnings contained in this manual. Anyone using this equipment should read this user manual.

INDEX

1 - OVERALL DESCRIPTION	PAG. 26
2 - TECHNICAL SPECIFICATIONS	PAG. 27
2.1 - TECHNICAL SPECIFICATIONS TANGO NEXT 125	PAG. 27
2.2 - TECHNICAL SPECIFICATIONS TANGO NEXT 188	PAG. 27
2.3 - TECHNICAL SPECIFICATIONS TANGO NEXT 250	PAG. 28
3 - NOTES AND WARNINGS	PAG. 29
4 - EQUIPMENT IDENTIFICATION	PAG. 29
5 - SAFETY	PAG. 30
5.1 - SAFETY WARNINGS FOR THE APPLIANCES USING R290 COOLING FLUID (PROPANE)	PAG. 30
5.2 - USE	PAG. 30
5.3 - SAFETY INFORMATION	PAG. 31
6 - INSTALLATION	PAG. 32
6.1 - STORAGE AND DISMANTLING	PAG. 32
6.2 - SELECTING THE PLACE OF INSTALLATION	PAG. 34
6.3 - POSITIONING	PAG. 34
6.4 - FRONT GRID	PAG. 35
6.5 - LOADING	PAG. 35
6.6 - MAX LOAD ON SHELVES	PAG. 36
6.7 - LIGHTING	PAG. 36
6.8 - FURTHER INFORMATION	PAG. 37
6.9 - DOOR OPENING	PAG. 37
6.7 - PUTTING INTO OPERATION	PAG. 38
7 - MAINTENANCE	PAG. 38
8 - CLEANING	PAG. 39
9.1 - OUTER CLEANING	PAG. 39
9.2 - INNER CLEANING	PAG. 39
9.3 - WATER COLLECTION TANK CLEANING	PAG. 39
9 - TEMPERATURE SETTING AND CONTROLS	PAG. 40
10 - MALFUNCTIONS AND REMEDIES	PAG. 41
11 - PROLONGED SWITCH OFF	PAG. 41
12 - DISPOSAL OF USED MATERIALS	PAG. 42
13 - INSERTION PROBE PT 1000	PAG. 42
14 - WIRING DIAGRAM	PAG. 43
14.1 - TANGO NEXT 125 WIRING DIAGRAM	PAG. 43
14.2 - TANGO NEXT 188 WIRING DIAGRAM	PAG. 43
14.3 - TANGO NEXT 250 WIRING DIAGRAM	PAG. 44
14.4 - WIRING DIAGRAM LEGEND	PAG. 44

SYMBOLS IN THE MANUAL

The manual uses some symbols to draw the reader's attention and highlight certain aspects which are particularly important to cover.

The meaning of the various symbols used follows:



ATTENTION! - Information on operator safety for refilling and the intactness of the machine and products.



ATTENTION! - Descriptions relating to the manual in question.



DANGER! - Electrical powered parts



DANGER! - Danger of inflammability.



ATTENTION! - Operations should only be carried out by staff specialising in extraordinary maintenance and repairs.



ATTENTION! - Use forklifts, pallet trucks, with adequate characteristics, driven by qualified staff.

1. OVERALL DESCRIPTION

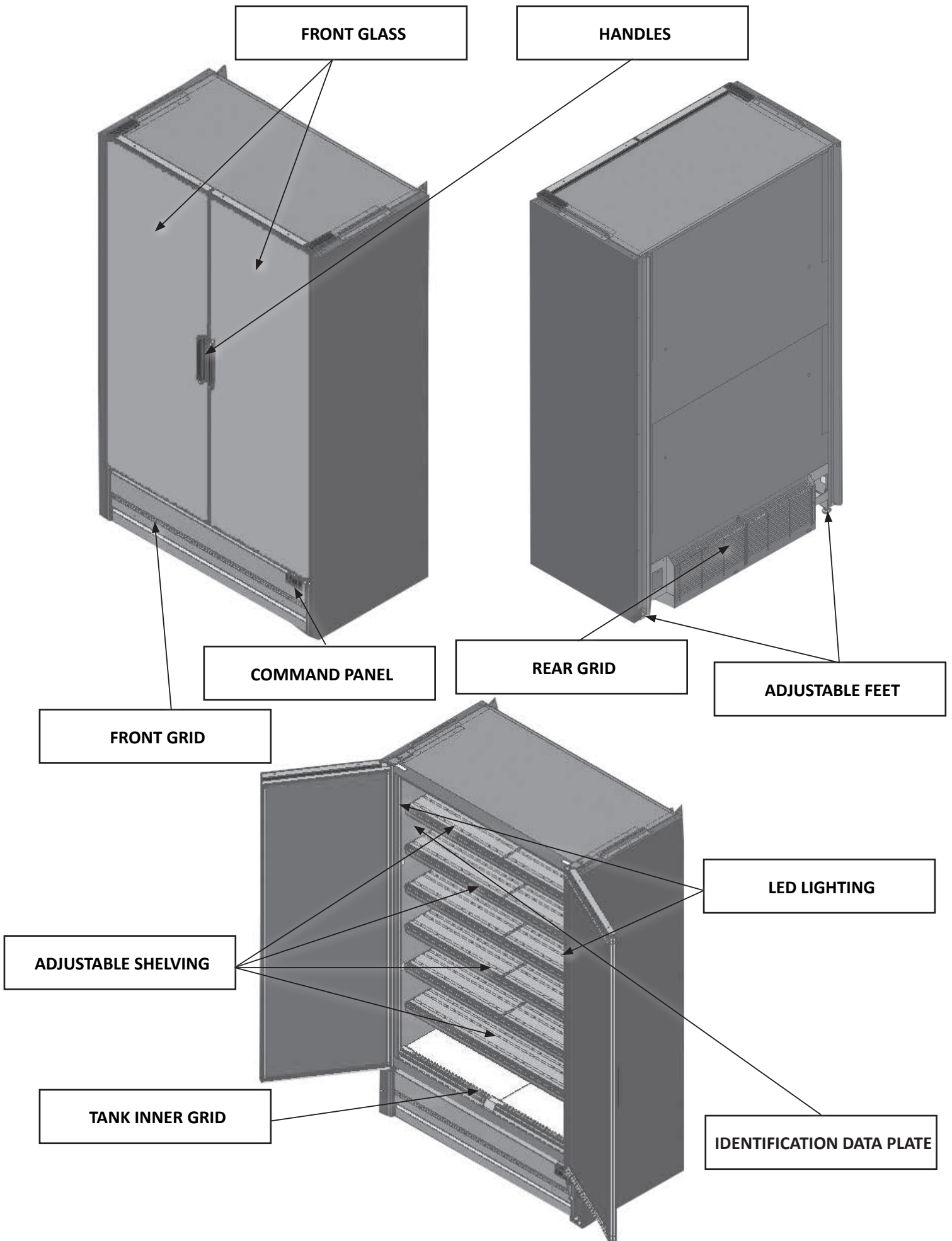

2. TECHNICAL SPECIFICATION

2.1 TANGO NEXT 125 TECHNICAL SPECIFICATION

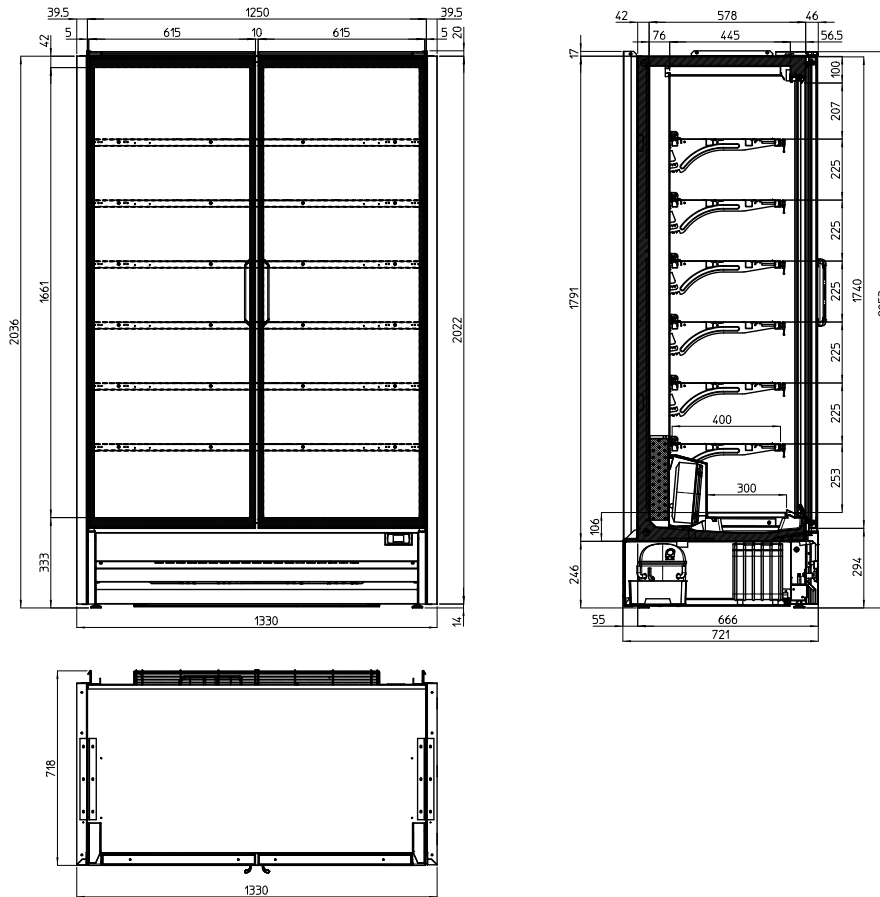

2.2 TANGO NEXT 188 TECHNICAL SPECIFICATION

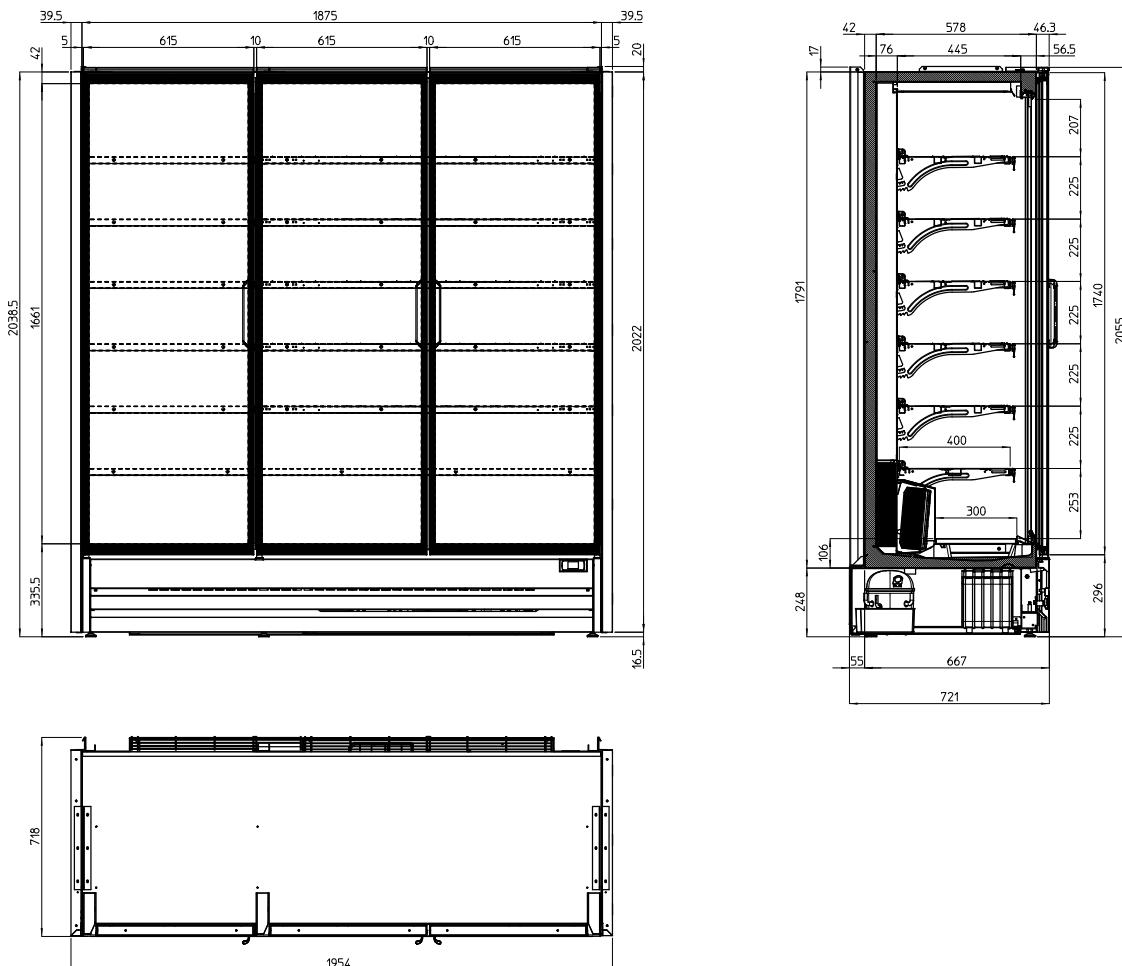

2.3 TANGO NEXT 250 SPECIFICATION

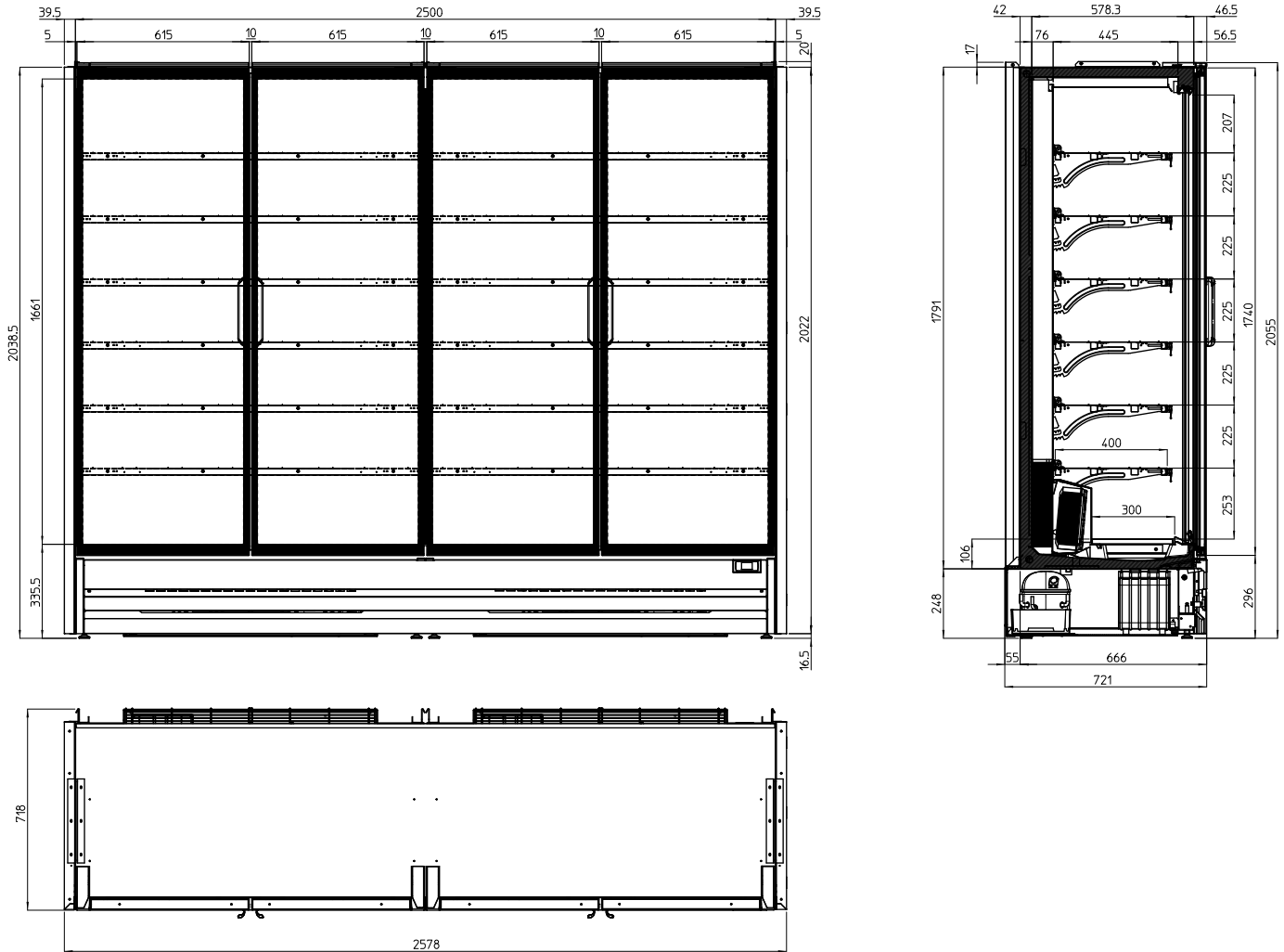

	125	188	250
External dimensions (Width x depth x High) (mm)	1330 x 721 x 2055	1954 x 721 x 2055	2578 x 721 x 2055
Gross volume (Liters)	973	1458	1944
Net volume (Liters)	673,5	1009,5	1345
Refrigeration	Fan	Fan	Fan
Defrosting	Automatic	Automatic	Automatic
Climate class	3	3	3
Temperature classification	M0 (+4°C / -1°C)	M0 (+4°C / -1°C)	M0 (+4°C / -1°C)
Refrigerant	R290	R290	R290
Electrical power supply (V / Hz)	230 / 50	230 / 50	230 / 50
Doors	2	3	4

3. NOTES AND WARNINGS



The content of this manual is technical and the property of EPTA s.p.a. It is forbidden to reproduce, distribute or modify entirely or partially its content without written authorisation. The owner company safeguards its rights pursuant to legislation in force.

The company cannot be held in any way liable for any damage to people, animals or the product conserved in the event of:

- Improper use of the equipment or use by unsuitable or unauthorised staff.
- Non-compliance with the standards in force
- Incorrect installation and/or faulty power supply
- Non-compliance with this manual
- Non-compliance with the maintenance program
- Unauthorised changes
- Installation of non-original spare parts on equipment
- Installation and use of the equipment for purposes other than those characterising design and sale
- Tampering with or damage to the power supply cable

Responsibility for application of the safety provisions outlined below is the responsibility of the technical staff responsible for the activities planned on the equipment, who must ensure the authorised staff:

- Are qualified to perform the task requested
- Know and strictly comply with the provisions contained in this document
- Know and apply the general safety standards applicable to the equipment

4. EQUIPMENT IDENTIFICATION

- Located on the plate affixed to the machine to detect the technical data.
- Check the model and power supply voltage before carrying out any operation.
- If discrepancies are found, immediately contact the manufacturer or the company that supplied the equipment.

1. Manufacturer
2. Model
3. Code
4. Conformity marking
5. Power supply voltage (V)
6. Power supply frequency (Hz)
7. Absorbed electrical power (W)
8. Light max. power (W)
9. Climate class
10. Type and quantity of refrigerant.

XXXXXX	Epta	MOD. DELIGHT ②	③ CE
		⑤ XXX V · ⑥ XX Hz	CLASSE CLIMATICA (EN 60335-2-89) X CLIMATIC CLASS(EN 60335-2-89) (30°C-55% R.H.)
dis.	POTENZA NOMINALE RATED POWER	⑦ XXX W	POTENZA IN SBRINAMENTO DEFROSTING POWER -
	CORRENTE NOMINALE RATED CURRENT	XX A	CORRENTE IN SBRINAMENTO DEFROSTING CURRENT -
XXXXXX	ESPANDENTE FOAMING AGENT	HC - CYCLOPENTANE	☀ ⑧ XX W ΛΛΛ XX W
	TIPO REFRIGERANTE REFRIGERANT TYPE	XXXa	QUANTITA' REFRIGERANTE REFRIGERANT AMOUNT XXX Kg
cod.	TIPO REFRIGERANTE REFRIGERANT TYPE	- ⑩	QUANTITA' REFRIGERANTE REFRIGERANT AMOUNT -
	CONTIENE GAS FLUORURATI AD EFFETTO SERRA DISCIPLINATI DAL PROTOCOLLO DI KYOTO; SISTEMA ERMETICAMENTE SIGILLATO CONTAINS FLUORINATED GREENHOUSE GASES COVERED BY THE KYOTO PROTOCOL; SYSTEM HERMETICALLY SEALED		
cod.	CLASSE CLIMATICA (EN23953) CLIMATIC CLASS (EN23953)	X /XX ⑨ (XX°C-XX%R.H.)	CODICE PRODOTTO PRODUCT CODE -----
	MATRICOLA SERIAL NUMBER		MATRICOLA DI PROPRIETA' PROPERTY NUMBER
	VOLUME LORDO GROSS VOLUME	XXX L	X



It is strictly forbidden to remove, tamper with the plate and change or alter the data contained in it.

5. SAFETY

5.1 SAFETY WARNINGS FOR THE APPLIANCES USING R290 COOLING FLUID (PROPANE)



Propane is a natural gas that doesn't affect the environment but is flammable. It is therefore essential to ensure that all refrigerant pipes are not damaged before connecting the appliance to the mains supply.

Every 8 gr. Of refrigerant, the installation room must have a 1 m³ minimum volume. The amount of refrigerant of the appliance is indicated on the rating plate of the device. In the event of leakage of the refrigerant, avoid using open flames or sources of ignition in the vicinity of the area of the leak. Be careful not to not damage the refrigerant circuit pipes during positioning, installation and cleaning.

Avoid using naked flames or sparks inside the appliance.



IN THE EVENT OF DAMAGE:

- Keep the appliance far from flames or ignition sources.
- Ventilate the room well for a few minutes.
- Switch off the equipment, remove the power supply plug.
- Inform customer service
- The higher the refrigerant content in the equipment, the larger the room must be hosting the equipment.
- In rooms that are too small, a mix of flammable air and gas can form in the event of a leak.



WARNING! Do not damage the refrigerant circuit.

WARNING! Do not damage the inner or outer walls of the appliance: the refrigerant fluid circuit may be damaged. In case of damage to the walls, do not start the appliance and contact a qualified service technician.



ATTENTION!

Maintenance must be carried out by technical staff trained and enabled for intervention on the flammable refrigerants.

5.2 USE

THE EQUIPMENT MUST ONLY BE USED TO CONSERVE, DISPLAY AND SELL BEVERAGES IN CANS OR BOTTLES.

The manufacturer cannot be held liable for damage caused by people, property or the equipment itself due to display of products other than the afore-specified.



















WARNING! Do not use electrical appliances inside the compartments of the appliance for storing frozen foods if these are not those recommended by the manufacturer.

WARNING! Never use mechanical devices or any other means to accelerate the defrosting process, other than those recommended by the manufacturer.

WARNING! Keep the ventilation openings in the appliance casing or in the recessed structure clear of obstructions.

WARNING! Do not store explosive substances such as aerosol cans with flammable propellant in this appliance.

5.3 SAFETY INFORMATION

-   Read the manual carefully and adhere to the contents before installing and using the appliance.
-  Always keep the instructions manual safe and if the appliance is sold, hand it over to the new owner.
-   This equipment is very dangerous if left exposed to rain, thunderstorms or bad weather with the power cable plugged into the power socket.
-  The children must be supervised to ensure that they do not play with the appliance.
-  The equipment must not be used by persons (including children) whose physical, sensorial, or mental capacities are reduced, or who lack experience and know-how, unless they have been provided, by means of a person responsible for their safety, with suitable monitoring or instructions about the use of the equipment.
Children must be monitored to ensure they do not play with the equipment.
-  Do not ever touch or handle the appliance with bare feet or with wet hands and feet.
-  The packaging materials, such as plastic bags, polystyrene, plastic cable ties, must not be left in reach of children as they are potential sources of danger.
-  Do not let children play with the appliance e.g. sitting in the baskets or rocking on or holding the cover, the cooler may overturn, or any items placed on top of it may fall down.
-  After installing the appliance make sure that it is not positioned on the power cable.
-  To disconnect the appliance from the mains, take out the plug.
Do not pull the power cable out of it.
-  If the coolant circuit is damaged, it is strictly necessary to turn off the lights.
-  Do not store explosives, such as pressurized containers with flammable propellant, in this appliance.
-  Never connect the cabinet to the power supply if it is damaged (in transit or otherwise).
When in doubt, contact your service organization or dealer.
-  If the supply cord is damaged, it must be replaced by the manufacturer, its service agent or similarly qualified persons in order to avoid a hazard.
-  Electronic elements may only be replaced by a qualified electrician or person with experience in electrical engineering.

6. INSTALLATION

6.1 STORAGE AND DISMANTLING

The unit is shipped anchored onto a wooden base and protected by corner posts, cardboard top and nylon wrapping. Keep all packaging away from children.

For each subsequent handling of the cabinet, the use of the wooden platform is recommended.

Carefully remove the packaging, taking care not to damage the components and not to throw away those that will be needed for assembly.



The unit is shipped anchored onto a wooden base and protected by corner posts, cardboard top and nylon wrapping. It must only be handled using a fork lift truck with adequate power to the load. Positioning the appliance horizontally or on its side or upside down is to be strictly avoided. The equipment **MUST** be kept vertical.

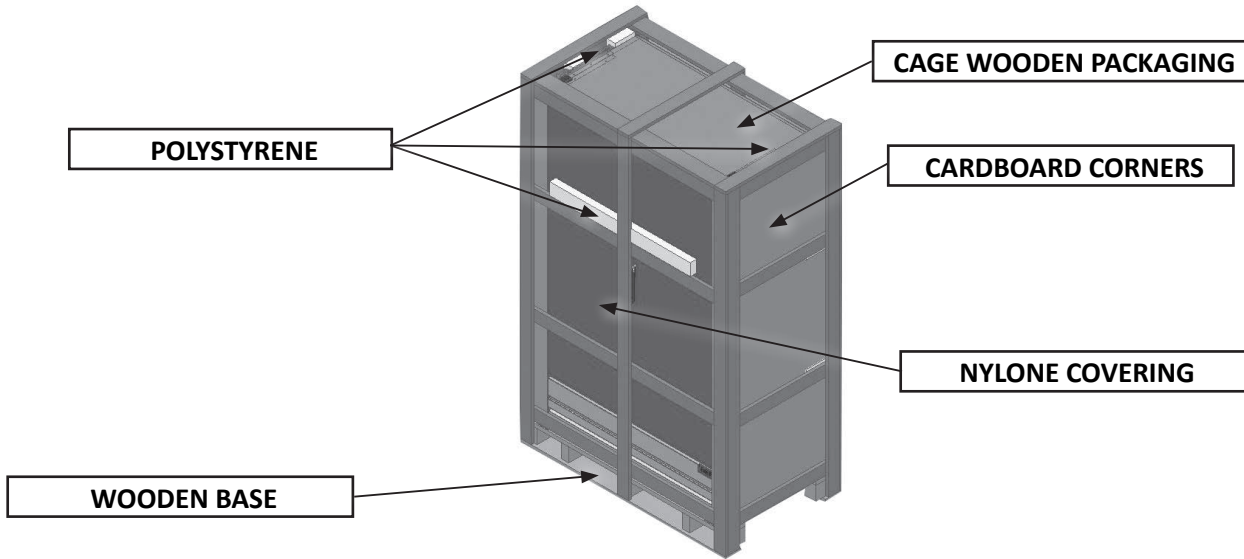

To unpack the bench proceed as follows:

1. Unscrew the screws and remove the wooden cage
2. Remove the plastic cover
3. Unscrew the 8 screws from the wooden base.
4. Using forklift the bench.
5. Remove the wooden base.
6. Position the bench adjusting the feet.



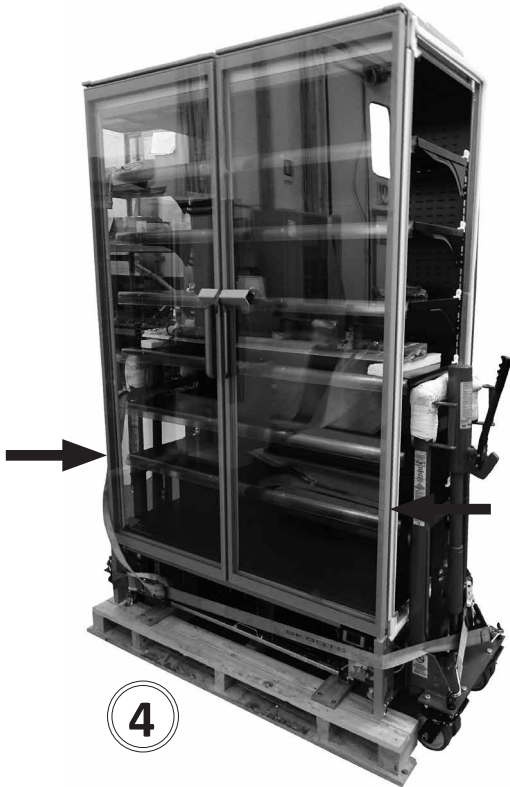
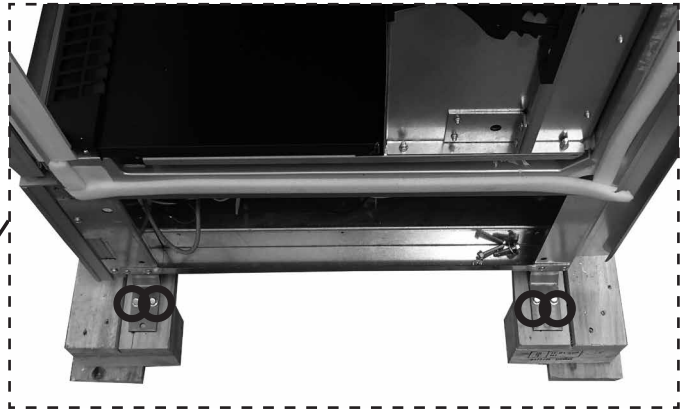

The appliance, equipped or not with its packaging, must be carefully stored inside warehouses or premises protected from bad weather, atmospheric agents and direct exposure to sunlight at a temperature between 0 and +40 °C.

6.2 SELECTING THE PLACE OF INSTALLATION

In selecting the place of installation, ensure that the following instructions are observed, this being vital for proper and troublefree working of the cabinet:

- Do not install the cabinet outdoors.
- Do not install the cabinet in the vicinity of heating radiators or other heat sources.
- Do not install the cabinet where it is exposed to direct sun light (e.g. through windows).
- Do not install the cabinet where it is exposed to drafts from ventilators open doors.
- Pay attention to air outlet from air conditioners/ ventilators.
- Keep the air intake and outlet area around the plinth area of the cabinet clear of cartons and other obstacles.
- It is necessary that the condensing unit obtains a good circulation of air around it; also the area around the condensing unit should not be obstructed by boxes or other objects; keep a distance from the wall of **10 cm.** at least.

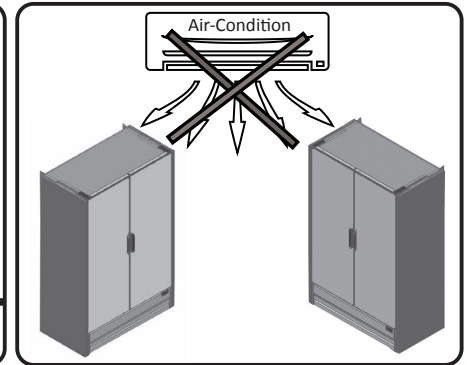
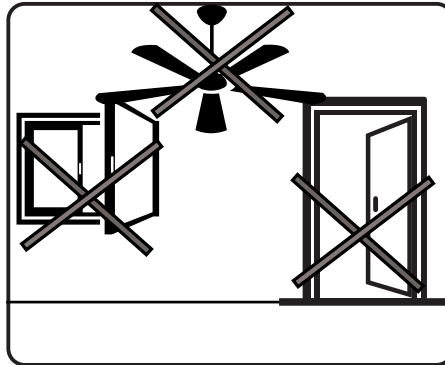
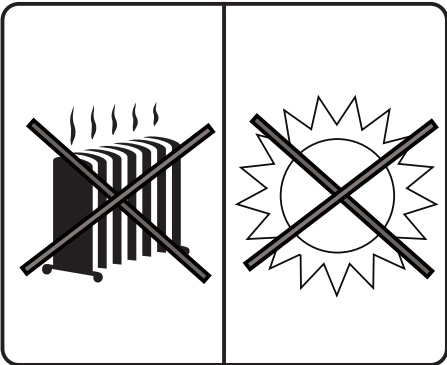
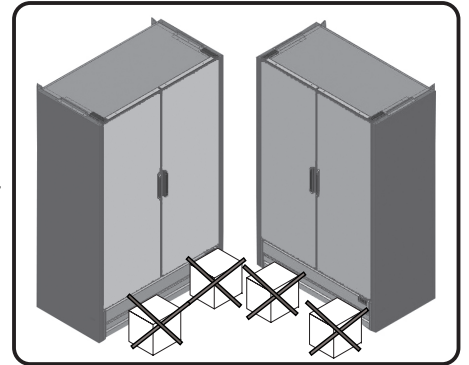

6.3 POSITIONING



The equipment comes with 4 small, adjustable feet for stabilisation on the floor.

It is strictly necessary after positioning to stabilise the equipment on the ground.

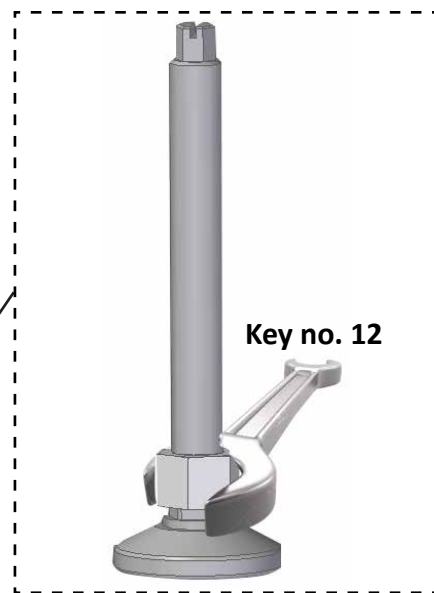
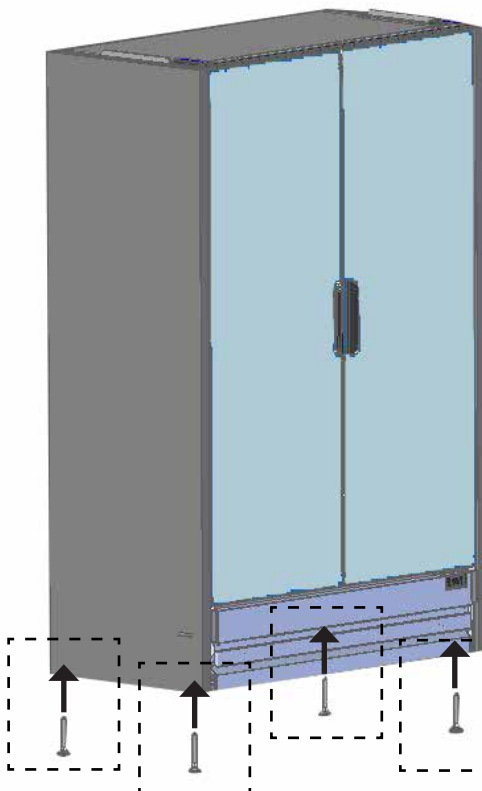

6.4 FRONT GRID



Having positioned the counter, screw in the front grid with the screws found supplied inside the counter.

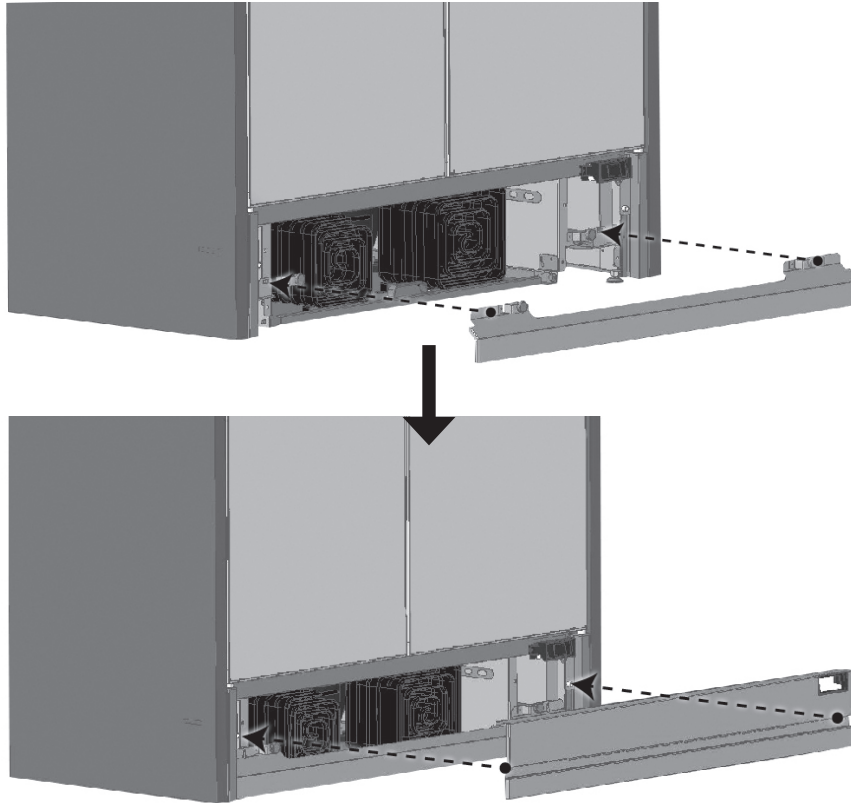

6.5 LOADING



It is fundamental not to exceed the load limits indicated to avoid altering correct air circulation and thereby avoid a higher product temperature.



WARNING:

- The product must not obstruct the display area completely.
- Avoid leaving shelves empty so as not to create turbulence which may prejudice refrigerated air flow, and cause needless energy consumption.

For the correct air circulation necessary to leave 4 cm free space between the product and the bottom of each internal shelf.

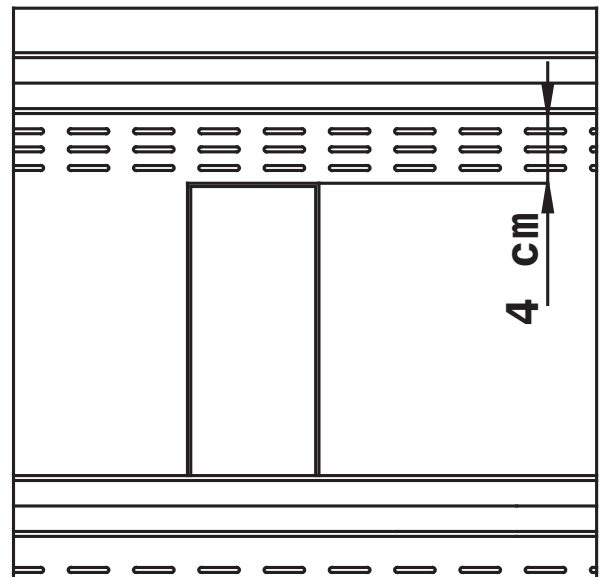

6.6 MAX LOAD ON SHELVES

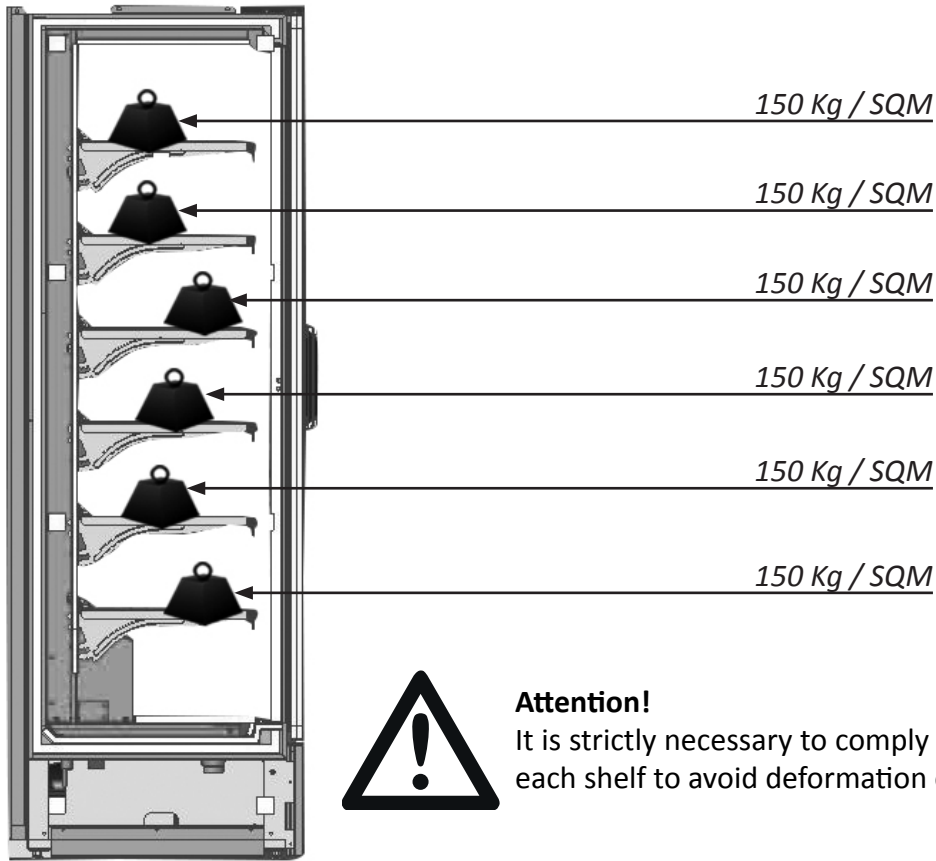

6.7 LIGHTING



Warning!

During product filling, maintenance and cabinet clearing it is mandatory to turn lights off. The operator must not stare at the lights.

Do not stare at operating lamp may be harmful to the eyes.

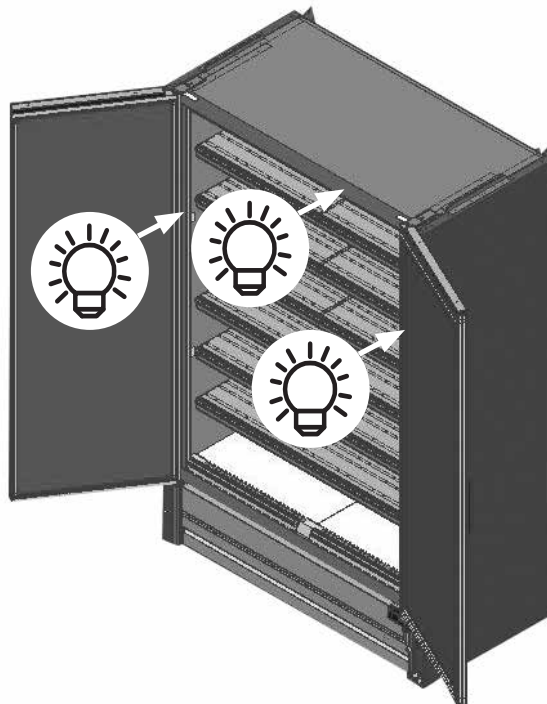

6.8 FURTHER INFORMATION

Take out packaging and clean all the cabinet using warm water together with 5% of neutral soap then dry it with a soft cloth; for the glass parts only use specific products, avoiding the use of water which can leave on the glasses limestone residues.

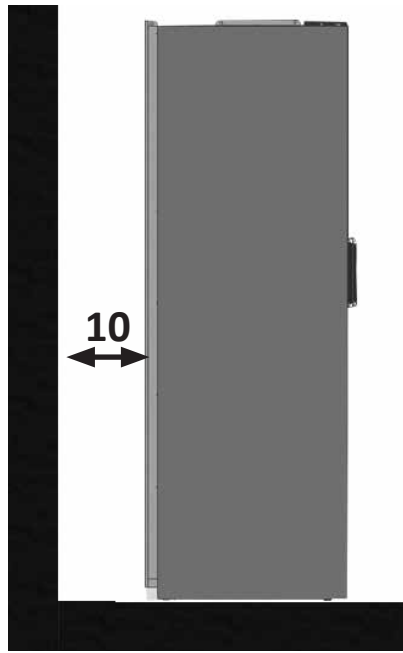

It is fundamental to comply with the distances indicated (cm) for correct installation of the equipment.

- Cabinet must be installed on a perfectly even surface, far away from any heat source (radiators, stoves, etc) including sun rays.
- It is necessary that the capacitor unit is in the free air exchange condition, therefore the ventilation zones must not be obstructed by boxes or otherwise.
- Install and position the unit in such a way so as to allow easy access to the power socket.
- Never place containers of liquid on or immediately above the ticket counter; should the content spill out, it would damage the counter.



THE REFRIGERATOR IS NOT SUITABLE FOR WORKING IN DANGEROUS ENVIRONMENT WITH RISK OF FIRE, EXPLOSIONS OR RADIATIONS.

Operation is regular with ambient temperature indicated on **technical data plate**.

6.9 DOOR OPENING



Warning!

MAXIMUM ANGLE OF DOOR OPENING = 120°

For correct working of the torsion bar and to avoid any break of the door or of the hinge do not exceed the maximum angle of door opening i.e. 120°.

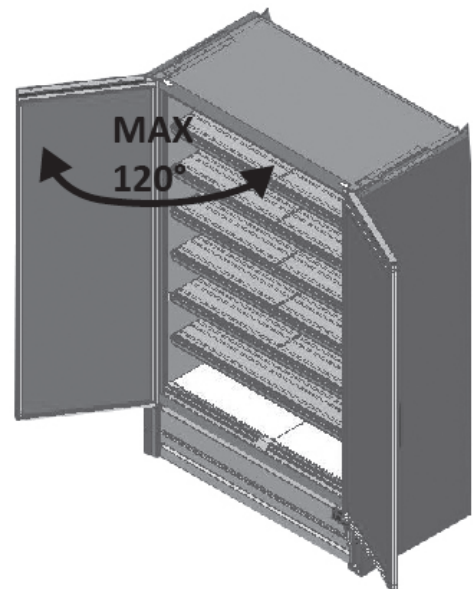

6.10 PUTTING INTO OPERATION



If the cabinet has been sharply tilted while being sited or for mounting of accessories, it must be left to stand for at least three hours before being started to allow the lubricating oil to settle in the compressor.

Failure to do so can cause total destruction of the compressor refrigerating system.



Check that the voltage on the identification plate is the same as that of the network.

THE ELECTRICAL SUPPLY LINE TO WHICH THE REFRIGERATOR WILL HAVE TO BE CONNECTED IS TO BE PROTECTED BY A VERY SENSITIVE DIFFERENTIAL SWITCH (Rc=16A,Dc=30mA); IT IS ALSO TO BE LINKED TO THE GENERAL EARTHING PLANT.



Follow the manufacturer's instructions to install the unit, using qualified personnel and complying with the electrical regulations for the specific country.

Incorrect installation may cause injury and damage; the manufacturer is not liable for this.

The manufacturer disclaims all responsibility for any damage to people or things due to incorrect observance of this rule.

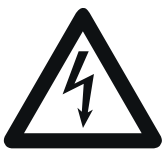

Earthing is necessary and compulsory by law. Absolutely never use reduction units, patch cords, adapters or multiple socket outlets to connect the counter.

DIRECTLY connect the equipment to the mains.

The cable should be fully extended and located where it is unlikely to be struck, caught or stepped on, away from water and the other liquids and heat sources and must not be damaged.

In case of breakage of the power cable of the cabinet, it must be replaced by the manufacturer or by instruction it change of it.

7. MAINTENANCE



WARNING!

ANY WORK CARRIED OUT ON THE APPLIANCE BY THE USER STRICTLY REQUIRES THE POWER PLUG BEING DISCONNECTED FROM THE MAINS SOCKET.

The equipment manager is obliged to check and comply with the maintenance deadlines in the table indicated below.

OPERATION	FREQUENCY	ORDINARY / EXTRAORDINARY MAINTENANCE	AUTHORISED STAFF
Cleaning the outer surface	Based on use	Ordinary	User
Cleaning the accessible inner parts (do not use tools)	Based on use	Ordinary	User
Checking the power supply, electrical plugs and/or sockets	Six-monthly	Ordinary	User
Seals intactness check	Six-monthly	Ordinary	User
Water collection tank cleaning	Based on use	Ordinary	Technical support
Fridge system tubing intactness check	Six-monthly	Ordinary	Technical support
Inspecting the cables and inner power connections	Six-monthly	Ordinary	Technical support
Replacing the led lights	-	Extraordinary	Technical support
Replacing the power supply cable	-	Extraordinary	Technical support
Control panel replacement (electronic control unit)	-	Extraordinary	Technical support



Any other maintenance operation not planned in the previous points should be carried out by the support centres authorised by our dealers or by qualified staff.

8. CLEANING

8.1 OUTER CLEANING

For a good preservation of the cabinet's body a **periodical cleaning is necessary**.

- ① **EXTERNAL BODY:** When necessary, the external body should be cleaned with a cloth and a neutral soap and water solution.
- ② **STAINLESS STEEL SURFACES:** Wash with warm water and mild detergent, rinse well and dry with soft cloth. Avoid scouring pads etc. which will spoil the finish of the stainless steel.
- ③ **SURFACES IN PLASTIC MATERIAL:** Wash with warm water and mild detergent, rinse well and dry with soft cloth; under no circumstances should alcohol, methylated spirits or solvents be used.
- ④ **GLASS SURFACES:** Only use products specifically designed for glass cleaning; It is not advisable to use ordinary water which can leave a film of calcium on the surface of the glass.



8.2 INNER CLEANING

By tank cleaning, proceed as follows:

1. Place the goods in special refrigerated containers, kept at the same temperature and remove the shelves
2. Unplug the unit.
3. Leave the doors open and begin the operation of tank washing when the tank temperature is the same as the ambient temperature.
4. Clean and dry the interior of the tank with a soft cloth, using neutral soap.
5. Then plug the unit and wait till the appliance reaches the right temperature before filling it again.

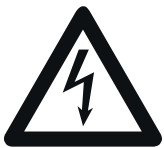

Do not use jet of water to clean the cabinet: electrical wiring could be damaged.
Never use mechanical devices or any other means to accelerate the defrosting process, other than those recommended by the manufacturer.

8.3 WATER COLLECTION TANK CLEANING



Attention!

Clean based on use and need and in particular environmental conditions (e.g. high humidity, low room temperature, presence of dust, etc.) to avoid incorrect and incomplete evaporation of water and/or presence of unpleasant odours.

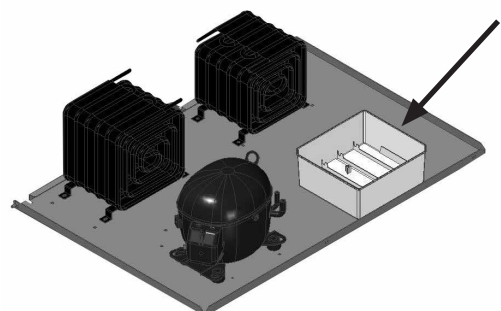

9. TEMPERATURE SETTING AND CONTROLS

Each refrigerating appliance is provided with an electronic control for automatic maintenance of the appropriate pre-established temperature inside the tank.

This temperature adjuster is gauged by the factory and should not be touched by the user.

Only if the average internal temperature is too cold or not cold you can increment or decrement the temperature:

- Press the **(Set) (2 sec.)** key in order to see on display the temperature set point.
- Press the **(▲)** key or the **(▼)** key in order to increment or decrement the temperature set point.
- Press the **(Set)** key in order to store the new temperature set point.

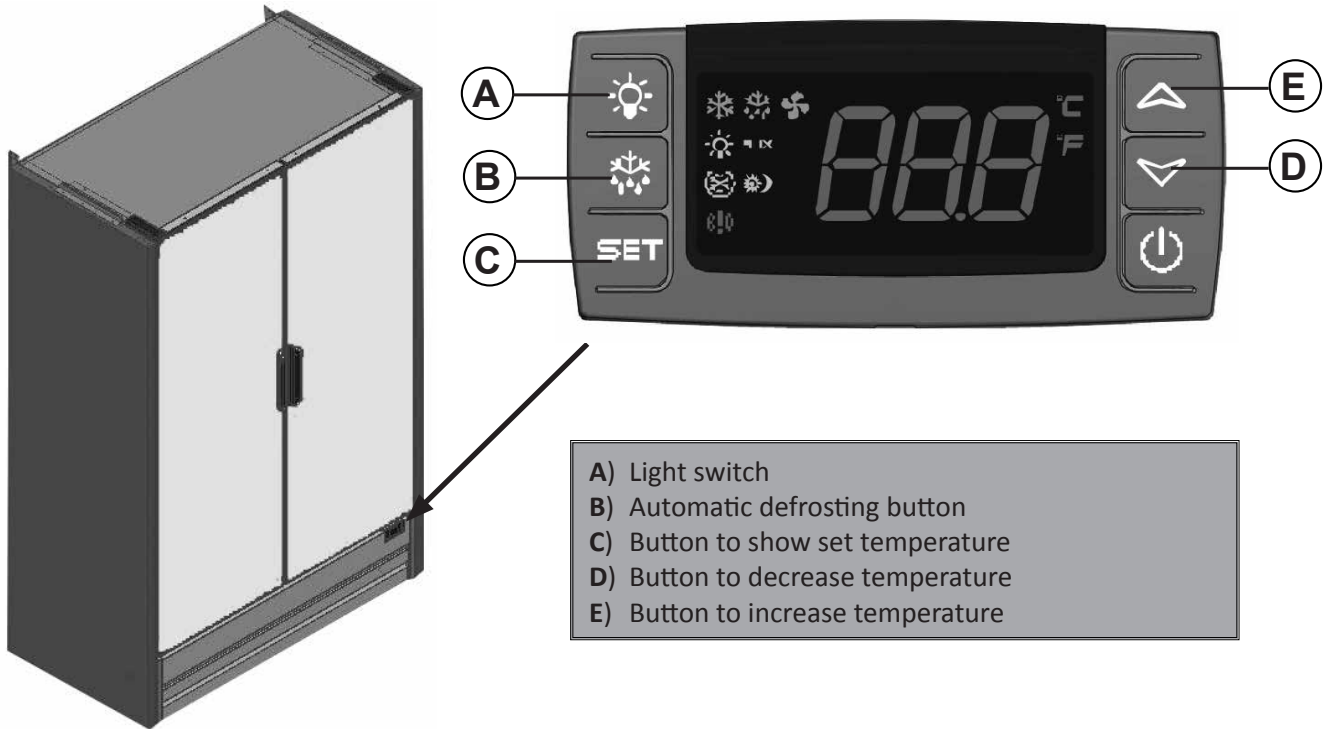

LED	MODE	Meaning
❄️	ON	Active compressor
	Flashing	Delay against close starts
❄️💧	ON	Defrosting in progress
	Flashing	Dripping in progress
🌀	ON	Fans on
	Flashing	Fans start delay in progress
🔊	ON	A temperature alarm activated
🔄❄️	ON	Continuous cycle in progress
☀️🌙	ON	Energy saving in progress
💡	ON	Light on
AUX	ON	Auxiliary active
°C	ON	Unit of measurement
	Flashing	Programming

10. MALFUNCTION AND REMEDIES

Most of the functioning inconveniences are generally due to simple causes or to defective electrical connections. These problems can usually be solved on site.

THE UNIT DOES NOT START

CAUSE	SOLUTION	AUTHORISED STAFF
Check that the unit is properly plugged	Insert the plug	User
Check that the unit is properly plugged	Insert the plug correctly	User
Check that the plug cord is broken	Replace the plug cable	Technical support

If power failure is not due to any of the above causes, call the nearest after-sales service immediately, empty the cabinet and store the foods in coldrooms or refrigerators that may ensure their preservation temperature.

THE INTERNAL TEMPERATURE IS NOT COLD ENOUGH

CAUSE	SOLUTION	AUTHORISED STAFF
Check door is perfectly closed	Close correctly	User
Make sure that the cabinet has been filled correctly	Load the product correctly	User
Check that the unit is not adjacent to sources of heat	Position the equipment correctly	User
Check that there is not too much ice on the evaporator	Defrost the equipment	User
Check the temperature setting	Set the correct temperature	User

If failure to cool should be not due to any of the above reasons it it persists on even after the above checks, resort to the nearest after-sales service.

L'APPARECCHIO È RUMOROSO

CAUSA	SOLUZIONE	PERSONALE AUTORIZZATO
Check that all the bolts and nuts are properly fastened	Screw in the screws	User
Check that the unit is placed on an even surface	Position the equipment correctly	User
Check if any pipe or fan is in contact with any other part of the body	Switch off the counter and distance the parts in contact in the event the problem persists, contact the support service.	Technical support

Should the inconvenience persist, contact the nearest after-sales service.

11. PROLONGED SWITCH OFF

Se la macchina dovesse rimanere inattiva per un certo tempo occorre effettuare le seguenti operazioni:

- Unplug the unit;
- Clean and dry the tank well;
- Cover the unit with a curtain, place it in a dry room and sheltered from the atmospheric agents.

12. DISPOSAL OF USED MATERIALS

IMPORTANT INFORMATION FOR CORRECT DISPOSAL OF THE PRODUCT IN ACCORDANCE WITH EC DIRECTIVE 2002/96/EC

At the end of its working life, the product must not be disposed of as urban waste.

It must be taken to a special local authority differentiated waste collection centre or to a dealer providing this service. Disposing of a household appliance separately avoids possible negative consequences for the environment and health deriving from inappropriate disposal and enables the constituent materials to be recovered to obtain significant savings in energy and resources. As a reminder of the need to dispose of household appliances separately, the product is marked with a crossed-out wheeled dustbin.



The symbol on the product or on the packaging indicates the product must not be considered normal domestic waste, but must be brought to an appropriate collection point for recycling of the electrical and electronic equipment.

By disposing of this product appropriately, you contribute to avoiding potential negative consequences, which could derive from inadequate disposal of the product.

For more detailed information on recycling of this product, contact the municipality office, the local waste disposal service or the shop where you purchased the product.



The cabinet contains oil, inflammable cooling gas, plastic and metallic components and glass.

WARNING!

Polyurethane insulation uses CICLOPENTHANE as expander, that doesn't affect the environment but is inflammable. To guarantee the same respect when it's disposed of, never abandon the equipment outside. Don't throw the packaging material from your equipment in the rubbish but sort the various materials: eg. polystyrene, cardboard, plastic bags.

The demolition of the cabinet and the recovery of the component materials must be carried out according to the local regulations in force in this matter.

13. INSERTION OF PROBE PT1000 (OPTIONAL)



The counter can have probe PT1000 supplied.

To access this probe, follow the instructions below:

1. Remove the rear covering (A).
2. Pass the probe PT1000 (B) in the hole of cover (A).
3. Insert and screw in the cover again (A).

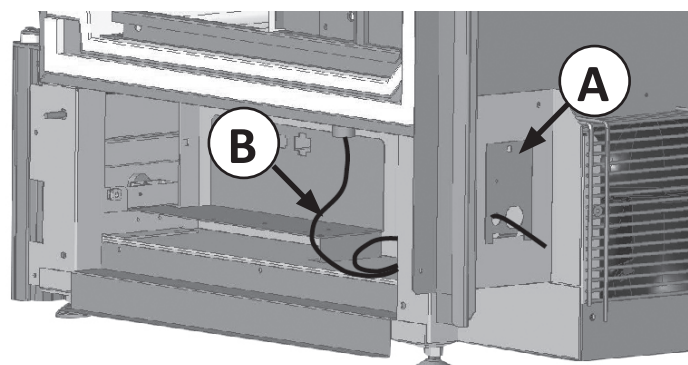
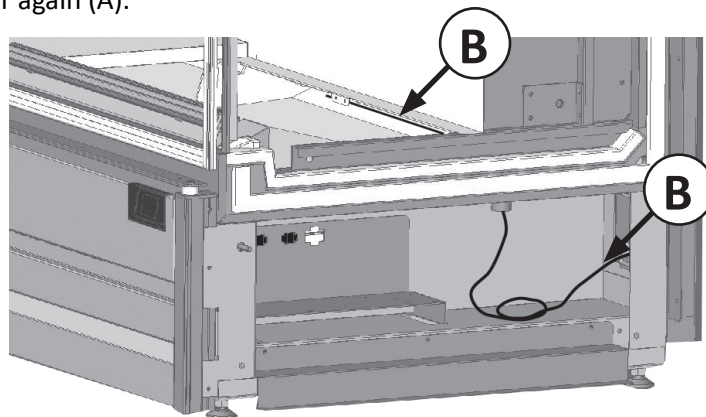
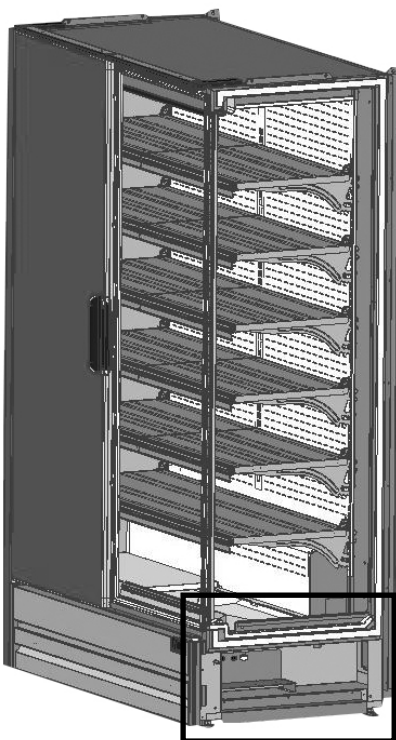



www.costan.com



Costan S.p.A. participates in the ECC programme for:
Refrigerated display cabinets (RDC). Check ongoing validity of
certificate online: www.eurovent-certification.com or using:
www.certiflash.com



www.eptarefrigeration.com