

LP3S

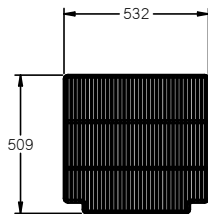

CATEGORY	GENERAL UPRIGHTS
RANGE	Pearl
UNIT	FREEZER
TYPE	SELF CONTAINED
DOORS	3



SHELF DETAIL

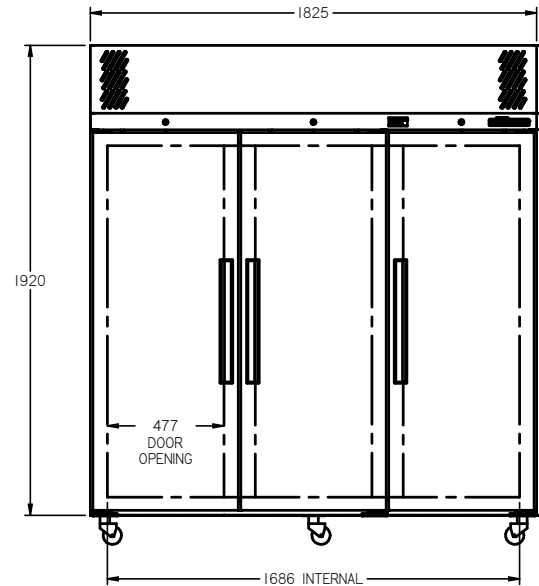
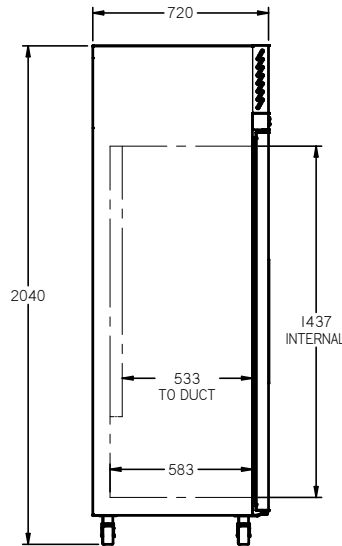
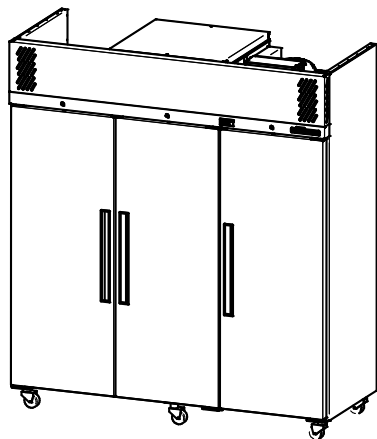
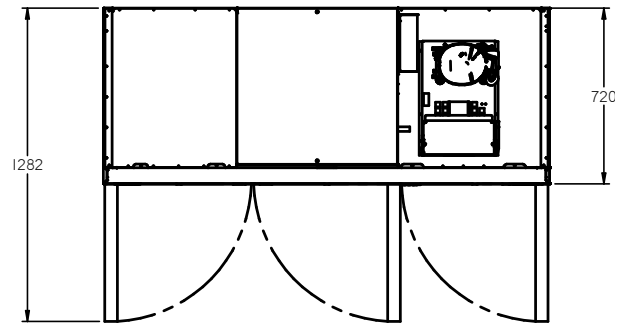

SPECIFICATIONS

CAPACITY LITRES	1510
TEMPERATURE	-18°C / -22°C
DIMENSIONS - W X D X H (ON 120 MM H CASTORS) MM	1825 W x 720 D x 2040 H
WEIGHT UNPACKED (KG)	290

STANDARD INCLUSIONS ***

DOOR TYPE	S (Solid Door)
FINISH (INTERIOR AND EXTERIOR EXCLUDING REAR AND UNDER)	W (White), B (Black), S (Stainless Steel)
SHELVES/DOOR (ADJUSTABLE STRIPS AND CLIPS)	4

GAS TYPE

REFRIGERANT	R404a
-------------	-------

ELECTRICAL

POWER SUPPLY	10 amp
POWER CABLE LENGTH (METRES)	2
RUNNING AMPS	6.1

PERFORMANCE

KWH/24HR READING	16.2
TEST STANDARD	EN 16825 (Professional)
TEST CONDITIONS	4 L1
AMBIENT RATING	43°C

REFRIGERATION WATTAGES FOR OPTIONAL REMOTE UNITS

FREEZER MODELS - SOLID DOORS (R404A)	1550 @ -30°C SST
--------------------------------------	------------------

*** For **OPTIONS** refer to the current Williams Price Guide