



eptarefrigeration

PLUG-IN POWER



SVABA LIDS



Customized graphic optional



Meat



Cheese



Dairy products



Fruits and Vegetables



Drinks



Frozen food



LED lighting



High efficiency fans



Propane refrigerant gas (R290)



Ventilated



Electric defrost



R404A 220V/1PH



Incorporated condensing unit



Medium & Low temperature

www.epta-asiapacific.com



eptarefrigeration

PLUG-IN POWER



TECHNICAL DETAILS



Model	Dimension L x W x H	Volumes in litres		Operating temperature	Energy consumption Kwh/24h	Q.ty on 20' container
		Gross	Net			
Svaba LIDS 150	1500x1010x930	266	170	-25°/+5°C	13,0 (BT) / 3,8 (TN)	14
Svaba LIDS 200	2000x1010x930	362	231	-25°/+5°C	18,7 (BT) / 4,7 (TN)	10

Model	Q.ty on 40' container	Packaging L x W x H	Cooling system	Refrigerant gas	Defrost system
Svaba LIDS 150	28	1642x1142x1130	Ventilated	R404A/R507/R290	Automatic
Svaba LIDS 200	22	2142x1142x1130	Ventilated	R404A/R507/R290	Automatic

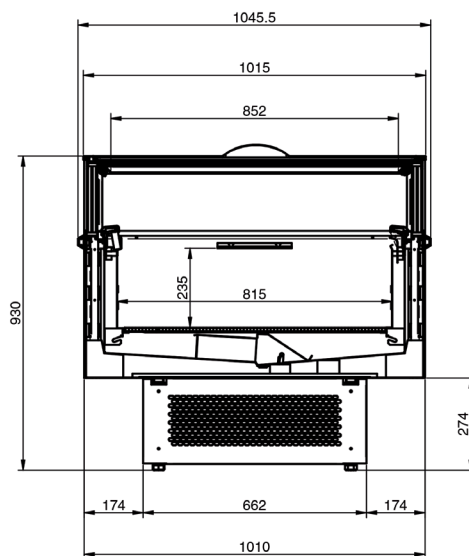
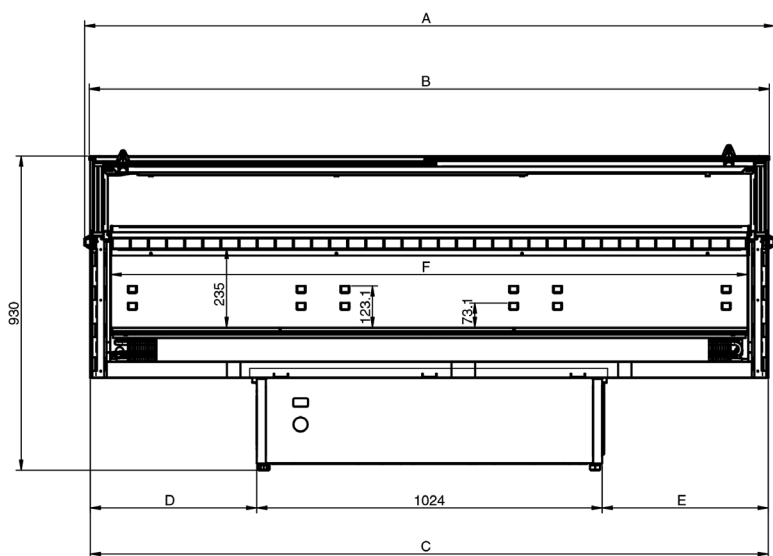

Model	A	B	C	D	E	F
Svaba LIDS 150	1545	1515	1509	243	242	1386
Svaba LIDS 200	2045	2015	2009	493	492	1886

ACCESSORIES



	STD	OPT
Wired base	●	
Electronic thermometer	●	
Wheels		●
LED light	●	