

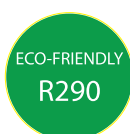

epirefrigeration

# SVABA LIDS

ISLAND DUAL TEMPERATURE



## FEATURES INCLUDE:

Electronic temperature control  
Automatic defrost  
High efficiency fan motors

LED lighting  
Customized graphic optional

**BAKER**

REFRIGERATION

Visit our website [www.ajbaker.com.au](http://www.ajbaker.com.au) or email us at [email@ajbaker.com.au](mailto:email@ajbaker.com.au)

Image used for illustration only.

# SVABA LIDS

ISLAND DUAL TEMPERATURE

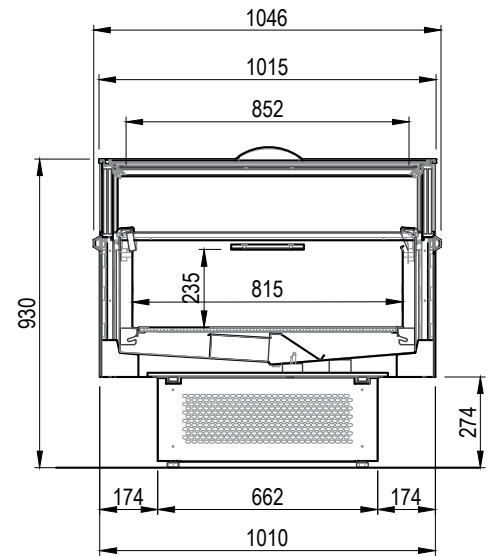
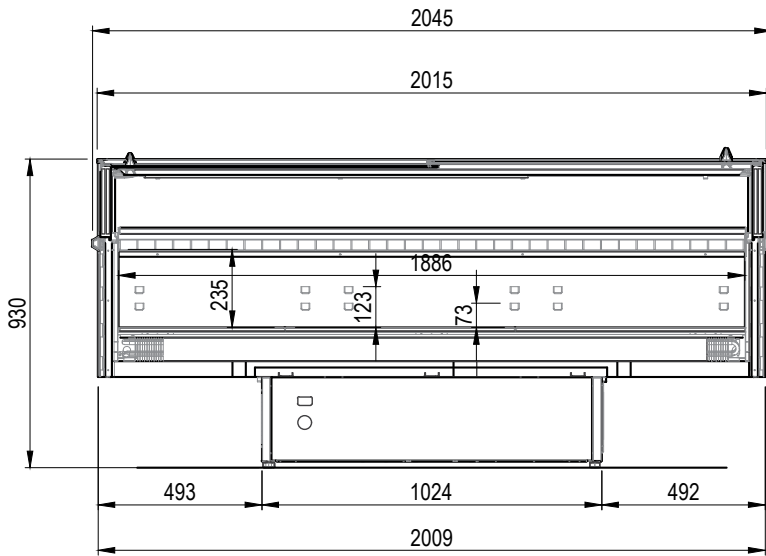

SVABA LIDS	150	200
* Operating Temp (°C)	-25/+5	
Refrigeration	Ventilated/R290	
Defrost	Automatic	
Power Supply	240V/1Ph/10 Amp plug	
Operating Current (Amp)	3.52	3.67
Nominal power (W)	810	845
Energy consumption (kWh/24h)	13.0 (BT model), 3.8 (TN model)	18.7 (BT mode), 4.7 (TN mode)
Total capacity (litr)	170	231
Length (mm)	1500	2000
Height inc castors (mm)	930	930
Depth w bumpers (mm)	1009	1009
Weight w/o packaging (kg)	170	200
Weight w packaging (kg)	200	262

\* Climate class 3 (25C, 60%RH)