

Supermarket Equipment KREA 190.3 N



PRODUCT CATEGORIES



TECHNICAL FEATURES





ACCESSORIES

- Logo
- Basket Support (3 pcs. per Cabinet)
- Standard safety System
- Basket Support Motor Compartment (1 pc. per Cabinet)
- Basket (6 pcs. per Cabinet)

TECHNICAL INFORMATION

Width (mm)	1868
Depth (mm)	862
Height (mm)	872
Volume in Litres Gross	805
Volume in Litres Net	525
Operating Temperature from	-25 °C
Operating Temperature to	-18 °C
Climate class	3 / L1
Cooling System	Static
Refrigerant Gas	R290
Energy Consumption kwh/24H –Class 3 Ambient 25°C –Ur 60%	6,90
Defrost System	Semiautomatic
Gross Weight (kg)	161
Net Weight (kg)	115
Package Dimensions (mm) (W x D x H)	1985 x 980 x 1005



KREA 190.3 N

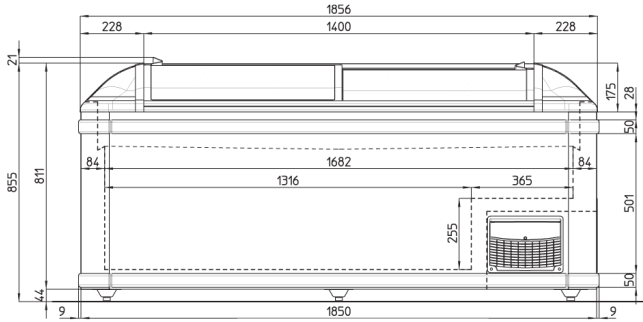

KREA 190.3 N

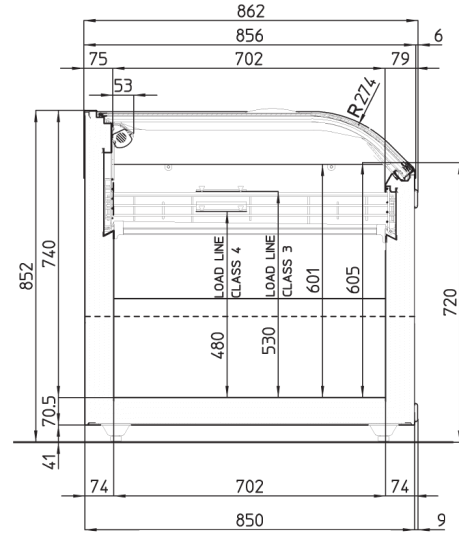

KREA 190.3 N

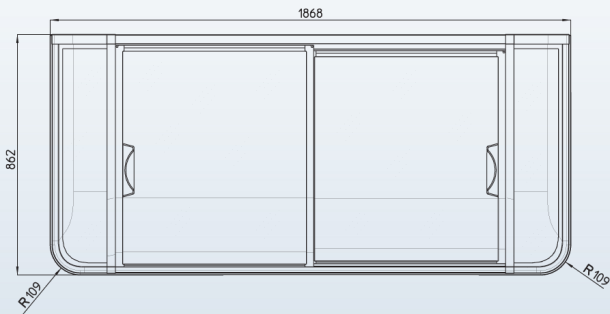



LEGEND



Sandwiches



Wines



Pharmaceuticals



Pastries



Dairy products



Ice creams and Frozen food



Fruit and Vegetables



Cheese



Meat



Drinks



LED lighting



Propane Refrigerant Gas (R290)



R600 / Isobutane



High efficiency fans



On board condenser



Electric controller



Free maintenance condenser



Incorporated condensing unit



R-134a



R404a – 400V/3PH/50Hz



Electric defrost



Off-cycle defrost



Hot-gas defrosting system



Manual defrost



Static



Ventilated



Compressor Hermetic Reciprocating