

KREA

CHEST FREEZER



FREEZER



R290



PLUG-IN

FEATURES INCLUDE

- Large storage capacity
- Electronic temperature control
- High efficiency fans
- Glass sliding lids
- LED lighting
- Anti-fog lids

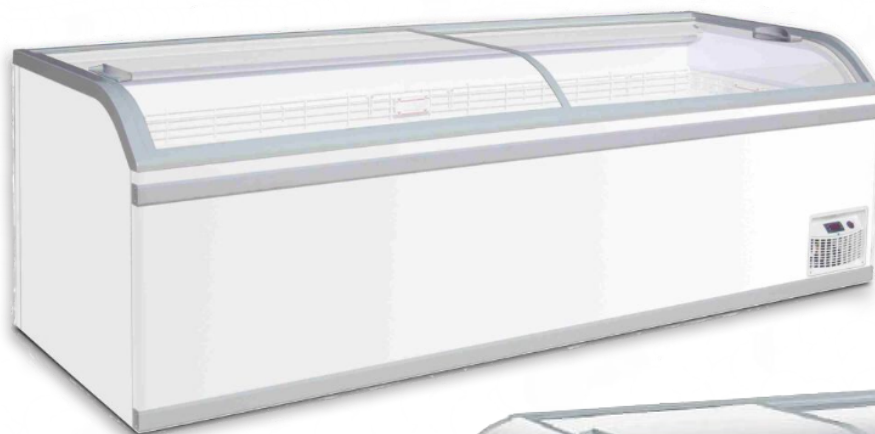

IARP KREA

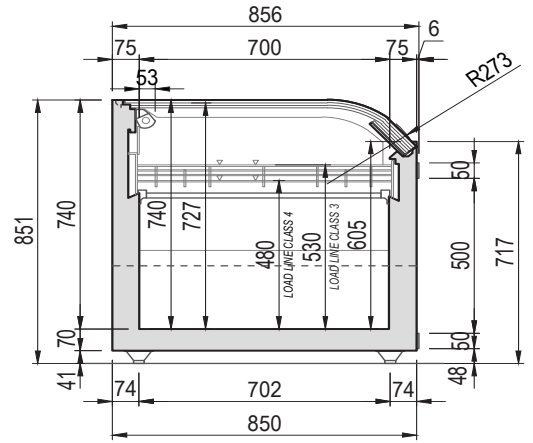
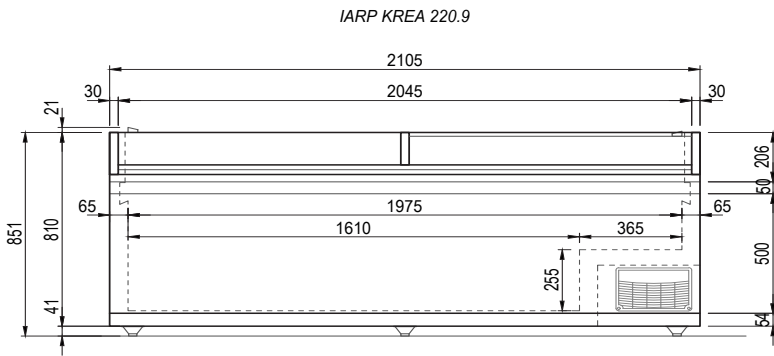

IARP KREA 260.9

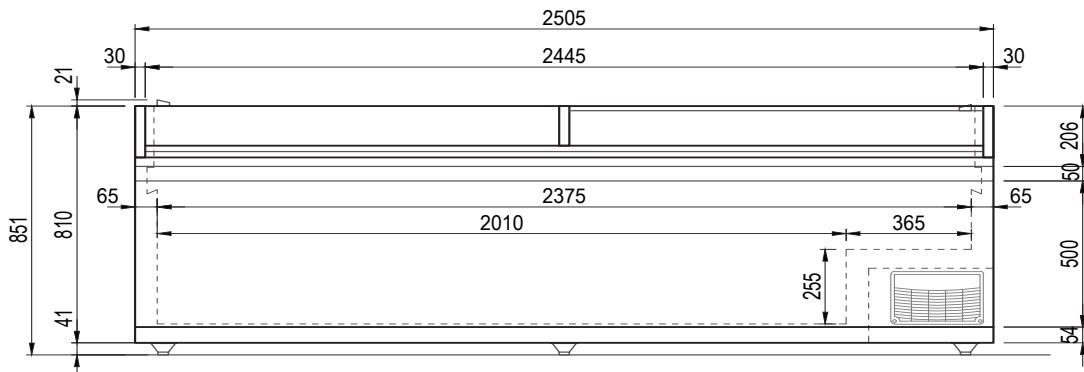

KREA	220.9	260.9
OPERATING TEMP (°C)	-25 / -18	
REFRIGERATION	Static / R290	
DEFROST	Semi-Automatic	
POWER SUPPLY	230V / 1Ph / 10 Amp plug	
OPERATING CURRENT (Amp)	3.1 - 3.5 (defrost)	
NOMINAL POWER (W)	520 - 710 (defrost)	
ENERGY CONSUMPTION (kWh/24h)	7.7	
NET VOLUME (lt)	767	
LENGTH (mm)	2105	2505
TOTAL HEIGHT (mm)	872	872
TOTAL DEPTH (mm)	856	856
WEIGHT WITH PACKAGING (kg)	202	202
WEIGHT WITHOUT PACKAGING (kg)	162	162

* Climate class 3 (25 °C, 60% R/H)