

# Ice Queen

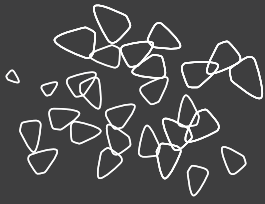

## IQ85

### Self-Contained Granular Ice Maker

SKOPE®

ITV | ICE makers



#### Features



- 88kg ice cube production in 24 hours
- Produces dry, granular ice
- Perfectly separated and consistent in size
- 20kg ice storage capacity
- Easy access external operational switches
- Strong solid AISI 304 stainless steel box-type frame
- Easy servicing without disassembling the whole machine
- Patented robust folding door with noise reduction system
- Flexible nozzle spray system to reduce build up of limescale
- Front and rear ventilation system allows machine to be built-in (ventilation clearances required)
- Cleaning switch allows circulation of water with descaling product (calclin or similar)
- Tropical T Class compressors suitable for use in environments up to 43°C ambient
- ITV designed motor pump, no seals to avoid deterioration
- Designed to allow easy disassembly and servicing for minimal disruption
- 2 year warranty
- **Installation must be carried out by a qualified plumber or refrigeration mechanic**

#### Supplied Accessories



Water Inlet  
Hose



Drain Hose



Gasket  
Washers



Medium  
Scoop



Adjustable  
height legs

Backflow prevention  
device

#### Water Filter



A Watermark approved\* water filter, suitable for the water type at the place of installation must be used. SKOPE can provide a water filter that protects the Ice Maker, and ensures proper function and high quality ice production. Service or repair due to absence of a suitable water filter will not be covered by SKOPE warranty. Contact SKOPE for more information.

\*Watermark approval is only applicable to Australian installations. Elsewhere, a suitable water filter must be used

## Machine Specifications

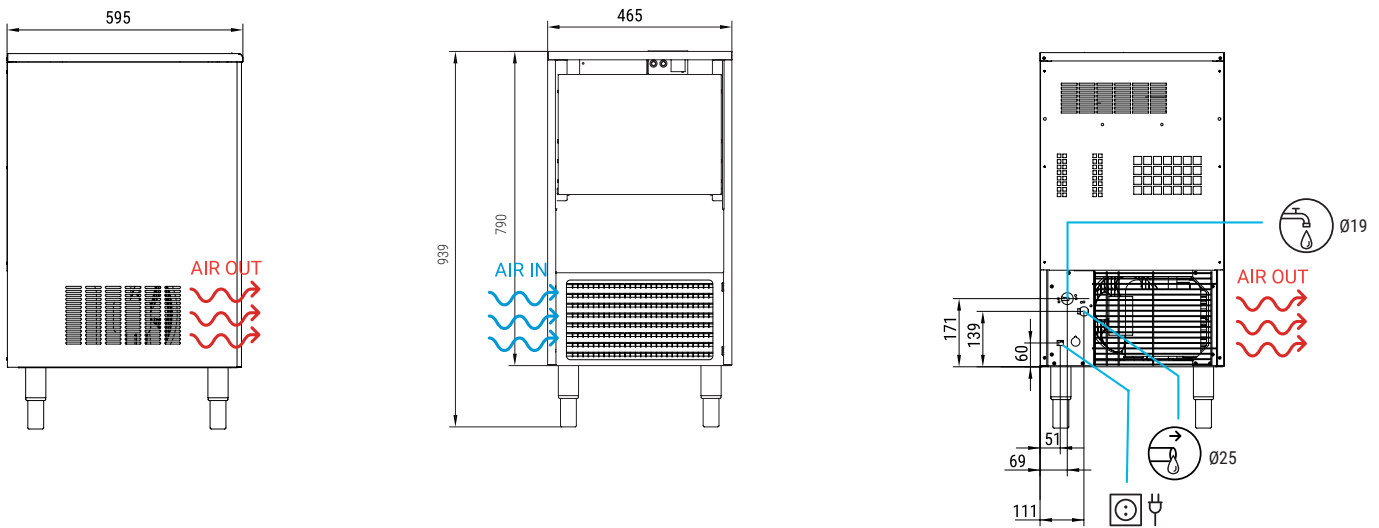

<b>Machine dimensions</b>	465 x 595 x 790mm
<b>Packed dimensions</b>	525 x 645 x 920mm
<b>Machine Weight</b>	58kg
<b>Packed Weight</b>	63kg
<b>Floor area</b>	0.31m <sup>2</sup>

### Ventilation recommendations

- 100mm behind the cabinet
- 100mm above the cabinet

(W)	(Btu/h)	(W) 43°C	(n.) (mm <sup>2</sup> )	FUSE	(Kwh)	(l/h)	(W) (Btu/h)
	741 2,529	550	3 1.5	10	12.7	3.9	562 1,917

## Ice Specifications



<b>Ice dimensions</b>	20% residual water content
<b>Ice cube volume</b>	n/a
<b>Ice cubes per cycle</b>	n/a
<b>Ice cube storage capacity</b>	20kg

### Ice production per 24 hour cycle (kg)

		Water temperature			
		10°C	15°C	21°C	30°C
Air temperature	10°C	89	84	79	72
	21°C	84	88	82	68
	32°C	84	78	74	60
	43°C	70	65	50	46



Electrical Safety & EMC  
Regulatory Compliance Mark



**2 Year Warranty Protection**  
Parts & Labour

### SKOPE INDUSTRIES LIMITED

Australian Freephone: 1800 121 535  
New Zealand Freephone: 0800 947 5673  
Email: skope@skope.com  
Website: www.skope.com