

HC1US

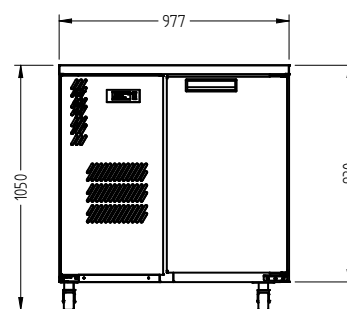

CATEGORY	GENERAL COUNTERS & BACK BARS
RANGE	Cameo
UNIT	REFRIGERATOR
TYPE	SELF CONTAINED
DOORS	1

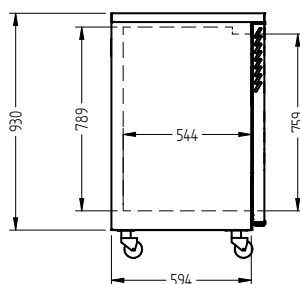
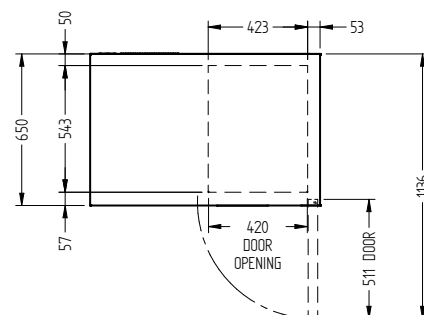

SPECIFICATIONS

CAPACITY LITRES	200
TEMPERATURE	1°C / 4°C
FRONT BREATHING	YES
DIMENSIONS - W X D X H (ON 120 MM H CASTORS) MM	977 W x 650 D x 1050 H
WEIGHT UNPACKED (KG)	160

STANDARD INCLUSIONS ***

DOOR TYPE	Standard: S (Solid Door)
FINISH (INTERIOR AND EXTERIOR EXCLUDING REAR AND UNDER)	B (Black with stainless steel countertop and internal floor) or S (Stainless Steel) interior and exterior excluding rear and under
SHELVES/DOOR (ADJUSTABLE STRIPS AND CLIPS)	2

GAS TYPE

REFRIGERANT	R134a
-------------	-------

ELECTRICAL

POWER SUPPLY	10 amp
POWER CABLE LENGTH (METRES)	2
RUNNING AMPS	2.1

PERFORMANCE

KWH/24H READING	2.83
TEST STANDARD	EN 16825 (Professional)
TEST CONDITIONS	4 M1
AMBIENT RATING	43°C

*** For **OPTIONS** refer to the current Williams Price Guide