

# GC1UGD

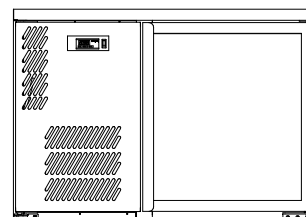

CATEGORY	GENERAL COUNTERS & BACK BARS
RANGE	<b>Glass chiller</b>
UNIT	REFRIGERATOR
TYPE	SELF CONTAINED
DOORS	1

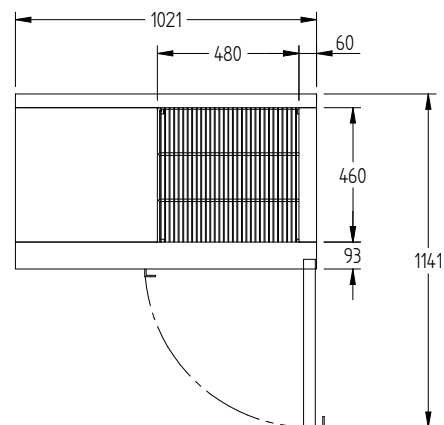
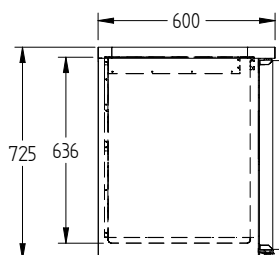

## SPECIFICATIONS

CAPACITY - BASKET/DOOR (NOT INCLUDED) (BASED ON 150MM H GLASSES)	3 Baskets
TEMPERATURE	1°C / 4°C
SHELF LOAD	YES
DIMENSIONS - W X D X H (ON 120MM H CASTORS) MM	1021 W x 600 D x 845 H
WEIGHT UNPACKED (KG)	100

## STANDARD INCLUSIONS \*\*\*

DOOR TYPE	Standard: GD (Glass Door)
FINISH (INTERIOR AND EXTERIOR EXCLUDING REAR AND UNDER)	SS (Stainless Steel)
SHELVES/DOOR - SHELF LOAD MODEL ONLY	2

## ELECTRICAL

POWER SUPPLY	10 amp
POWER CABLE LENGTH (METRES)	2
RUNNING AMPS	3.6

## GAS TYPE

REFRIGERANT	R134a
-------------	-------

\*\*\* For **OPTIONS** refer to the current Williams Price Guide