

OPEN DISPLAY FRIDGE

FOD-72VS

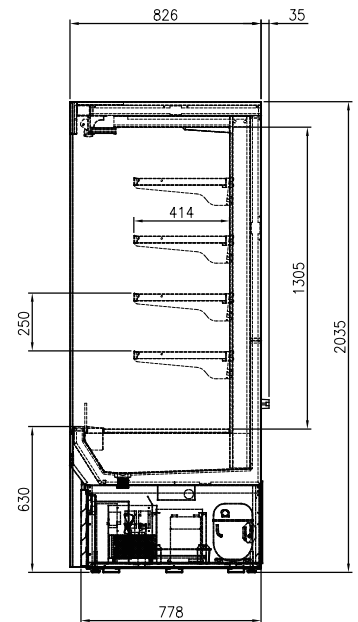
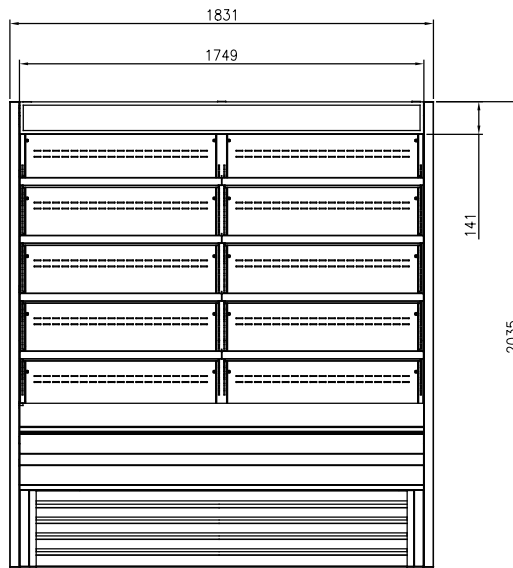
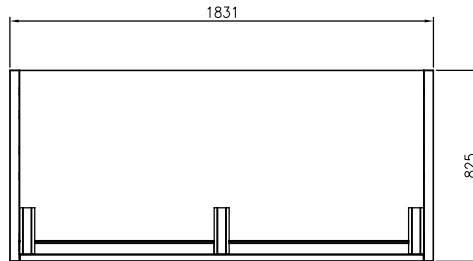

FEATURES

- LED lights for each shelves
- Transparent night curtain for energy efficiency
- Angle adjustable shelves
- LED sign panel

- Leg levelers available
- 4" casters
- Digital temperature display

TEMPERATURE

- 0°C ~ 5°C

OPTIONAL MODELS

- Remote model
- Electronic control with exterior digital display

Model	Capacity (ℓ)	Exterior Dimension (mm)			Net Weight (kg)	Gross Weight (kg)	Amps	Power Supply	Voltage (V/Hz/Ø)	Watt	HP	Refrigerant	No. Shelf	No. Night Curtain
		W	D	H										
FOD-72VS	1,162	1,831	826	2,035	337	359	9.5	30A	240/50/1	3500	1 × 2	R-404A	8	2

* Design and specifications subject to change without notice
 * Actual shipping weight may differ due to extra packing materials for product protection.
 * The height DOES NOT include the 4" caster (125mm)