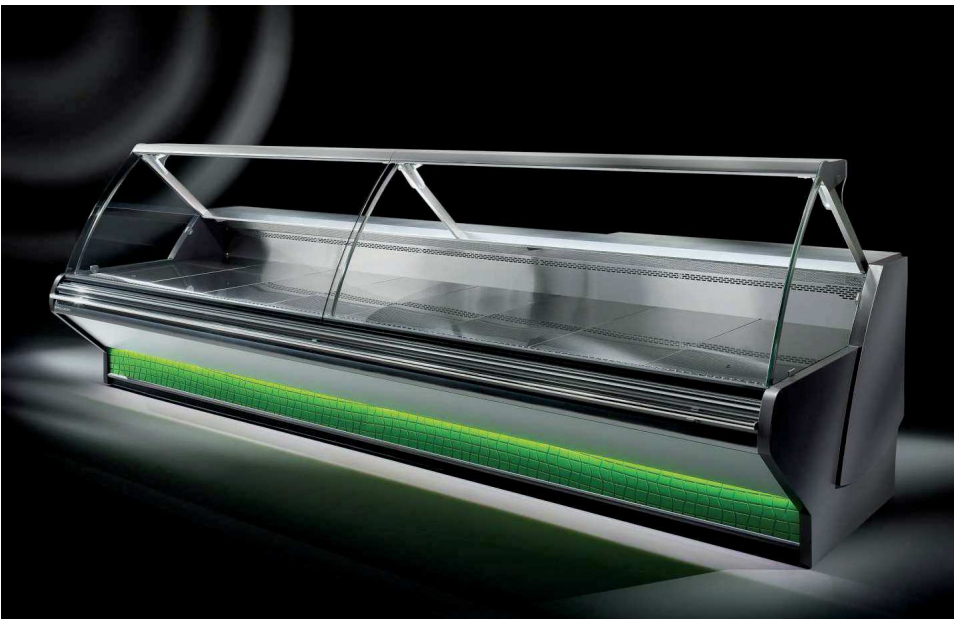


# ERGO

## INSTRUCTION MANUAL





|   |    |
|---|----|
| 1. Introduction .....   | 5  |
| 1.1 Introduction and purpose of the Manual .....                | 5  |
| 1.1.1 Use of this Manual .....                                  | 5  |
| 1.2 Warranty conditions .....                                   | 5  |
| 1.3 Graphical conventions .....                                 | 5  |
| 1.4 Personnel qualifications .....                              | 6  |
| 1.5 General warnings .....                                      | 6  |
| 1.5.1 To be arranged by the Customer .....                      | 7  |
| 1.5.2 Technical assistance .....                                | 7  |
| 1.5.3 Spare parts .....   | 7  |
| 2. Information on safety .....                                  | 8  |
| 2.1 General regulations - Training .....                        | 8  |
| 2.2 General regulations - Skills and checks .....               | 8  |
| 2.3 Fire regulations .....                                      | 8  |
| 2.4 First aid regulations .....                                 | 8  |
| 3. Product specification .....                                  | 10 |
| 3.1 General description .....                                   | 10 |
| 3.1.1 Structural components .....                               | 10 |
| 3.1.2 Control system .....                                      | 12 |
| 3.2 Technical characteristics .....                             | 13 |
| 3.2.1 Dimensions .....  | 13 |
| 3.2.2 Lay-out .....   | 15 |
| 3.2.3 Weight table .....  | 19 |
| 3.2.4 Admissible loads .....                                    | 19 |
| 3.2.5 Refrigeration system: .....                               | 19 |
| 3.3 Noise level .....   | 19 |
| 3.4 Other emissions .....                                       | 19 |
| 3.5 Environmental requirements for operation .....              | 19 |
| 3.6 Description of residual risks .....                         | 20 |
| 3.7 Specific protections .....                                  | 21 |
| 4. Instructions for commissioning .....                         | 21 |
| 4.1 Transport, handling and positioning .....                   | 21 |
| 4.1.1 Precautions to be taken upon receipt of the product ..... | 21 |
| 4.1.2 Handling and positioning .....                            | 22 |
| 4.2 Unpacking and disposal of packaging materials .....         | 23 |
| 4.3 Assembly .....  | 24 |
| 4.4 Disassembly and subsequent reassembly .....                 | 44 |
| 4.5 Fixing .....  | 44 |
| 4.6 Installation .....  | 44 |
| 4.6.1 Connection to a remote condensing unit .....              | 44 |
| 4.6.2 Connection to the mains .....                             | 44 |
| 4.6.3 Connection to the drain line .....                        | 44 |
| 4.7 Commissioning .....   | 45 |
| 4.7.1 Setting .....   | 45 |
| 4.8 Idle time and restarting .....                              | 45 |

|   |    |
|---|----|
| 5. Instructions for use .....                     | 45 |
| 5.1 Correct use of the cabinet .....              | 45 |
| 5.2 Uses to be avoided .....                      | 46 |
| 5.3 Working limits .....                          | 46 |
| 5.4 Cabinet control functions .....               | 46 |
| 5.4.1 Manual defrosting .....                     | 46 |
| 6. Maintenance instructions .....                 | 47 |
| 6.1 General warnings .....                        | 47 |
| 6.2 Periodical cleaning .....                     | 47 |
| 6.3 Periodical maintenance .....                  | 48 |
| 6.3.1 Check of the glass lifting system .....     | 48 |
| 6.4 Special maintenance .....                     | 48 |
| 6.5 Troubleshooting .....                         | 48 |
| 7. Instructions for demolition and disposal ..... | 48 |
| 8. Attachments .....                              | 49 |
| 8.1 Reference to manuals of other suppliers ..... | 49 |
| 8.2 Declaration of conformity: as attached .....  | 49 |

---

## 1. Introduction

---

### 1.1 Introduction and purpose of the Manual

---

Thank you for choosing Criocabin S.p.a., hereinafter referred to as the Manufacturer. We are glad to have you as our Customer and hope you will be fully satisfied with this product.

**This Use and Maintenance Manual is an integral part of the product and is aimed at anyone who works on the product or interacts with its users.**

The purpose of this Manual is to supply the necessary information to enable:

- *quick identification of the product parts;*
- *all the commissioning, functioning and maintenance operations to be carried out on the product;*
- *the health and safety of all users and exposed persons to be guaranteed at all stages.*

All information, drawings, diagrams, tables and any other contents of this Use and Maintenance Manual are confidential and therefore the full or partial reproduction or disclosure thereof to third parties is subject to the authorisation of the Manufacturer in its capacity as sole owner.

#### 1.1.1 Use of this Manual

Read this manual before handling, installing and using the product, and likewise before carrying out any maintenance work on it.

The term Manufacturer will always be used to indicate Criocabin S.p.a., while the generic term Supplier will be used to indicate other manufacturers of specific components fitted in the product.

The term Dealer will be used to indicate the company that, according to a distribution agreement signed with the Manufacturer, is authorised to sell the product and constitutes the Customer's commercial counterpart.

Keep this manual away from sources of heat, dampness and corrosive agents throughout the product working life, pass it on to any other user or subsequent owner and keep it handy for easy reference by its users.

Handle this manual with care; do not damage it, tear out pages or modify its content for any reason.

The Manufacturer reserves the right to communicate at any moment any information which is considered necessary for a better and safer use of the product. Such information, provided as modifications, updating or additions, will have to be considered in all respects as an integral part of this manual.

### 1.2 Warranty conditions

---

Warranty conditions are stated in the sales agreement which is accepted by the Customer by means of order confirmation.

### 1.3 Graphical conventions

---

**Bold type** is used to highlight information considered important.

References to illustrations are made by means of a number in **bold type** that identifies the illustration (i.e. **Fig. 1**) and, if necessary, by means of a letter or number that identifies the component in question

within the illustration. Illustration references and component references may be used at the same time (i.e. **A - Fig. 1** or **1 - Fig. 1**).

The following graphical symbols are used in this Manual to draw users' attention to information concerning proper and safe use of the product:



**NOTE!**

This symbol is used to highlight a piece of information or advice, or a rule which is considered particularly important.



**CAUTION!**

This symbol is used to point out a dangerous operation or situation.



**PROHIBITED OPERATION!**

This symbol is used to indicate a prohibited operation.

Additionally, the graphical symbols listed below are employed in this manual to show the Personal Protective Equipment which must be worn when installing, using and maintaining the product.

The symbol for each safety device will be found whenever a specific operation requires use of said device.



**PERSONAL PROTECTIVE EQUIPMENT**

This symbol indicates that it is compulsory to wear protective gloves during operations marked by this symbol.

**1.4 Personnel qualifications**

Here follows a description of the type of personnel to whom this Manual is addressed.



**Qualified**

The Qualified Technician is a specialised technician who is supplied by the Customer or by the Dealer and is authorised, under different circumstances, to carry out operations such as assembly, disassembly, installation, set-up, start-up, maintenance and repair.

**1.5 General warnings**

All the indicated safety regulations must be strictly observed by the users of the product.

The instructions written on this Manual will be the object of a training activity given by the Dealer's technical personnel during installation. The Customer will be responsible for selecting, inside their organisation, the people to whom such training activity is addressed and for checking that the trained personnel have reached a learning level which is apt for the tasks assigned to them.

The diagrams enclosed in this Manual are to be used only for extraordinary maintenance and controls.



**Note!**

It is strictly forbidden to use them to carry out modifications on the product. Possible modifications are to be required directly to the Dealer, specifying all the product technical features and the reasons for such modifications; if approved, modifications must be carried out only by the Manufacturer's personnel or by authorised personnel.



**Note!**

Any non-authorised tampering/replacement of one or more parts or units of the product may cause accidents and exempt the Manufacturer from civil and criminal liability.

### 1.5.1 To be arranged by the Customer

Provided for otherwise by special contractual conditions, the Customer is responsible for arranging the following:

- selecting the people to whom the training on the product use is addressed;
- arranging a suitable place for product installation;
- checking that the received product corresponds to the order specifications;
- carrying out all the activities described in the present manual, except where expressly indicated otherwise.

### 1.5.2 Technical assistance

The Customer may require technical assistance by contacting directly the Dealer's Customer Service according to the ways specified in the Sales Agreement.

### 1.5.3 Spare parts



**Note!**

The Customer must always use original spare parts supplied by the Manufacturer. The Manufacturer cannot be held responsible for any damage or injury or any other inconvenience arising from the use of non-original spare parts.

Drawing, references, descriptions and serial numbers for the identification of all the mechanical parts are listed in the section **Spare Parts**.

With regard to the electrical and electronic equipment, please refer to the electrical diagrams 1 and 2.



**Note!**

When ordering new spare parts, always quote the model and serial number of the product for which the spare parts are required.

---

## **2. Information on safety**

---

### **2.1 General regulations - Training**

---

- *It is recommended that any person who interacts with the product reads this Manual completely before starting to operate.*
- *Negligence or failure to comply with these safety regulations while using and maintaining the product may cause accidents for which the Dealer and the Manufacturer are not responsible.*
- *Finally, it is hereby reminded that according to the provisions of the law in force:*



**Note!**

**Workers must follow the orders and instructions given by the employer.**

### **2.2 General regulations - Skills and checks**

---

- *Only qualified and authorised technical personnel can install, set and carry out extraordinary maintenance on the product.*
- *The product has been designed only for holding food and shall not be used for any other purpose.*
- *Always use the Personal Protective Equipment when recommended.*
- *Arrange fire-fighting equipment adequate to the product technical features.*

### **2.3 Fire regulations**

---



**Warning!**

When put in contact with free flames, the refrigerant fluid undergoes a thermal decomposition into a caustic and poisonous substance.

Avoid exposition to sparks and sources of inflammation.

### **2.4 First aid regulations**

---

The following first aid regulations concern the treatment of injuries that could be caused by the refrigerant fluid.



**Warning!**

**If a refrigerant fluid comes into contact with eyes:**

do not rub the eyes;  
remove contact lens;  
rinse thoroughly for at least 20 minutes.



**If a lubricant comes into contact with skin:**

wash the skin with a great quantity of water for at least 20 minutes;  
leave the skin uncovered.

**If a lubricant is swallowed:**

drink as much water as possible.

**In all the above cases, bring the injured person to the nearest medical facility.**

**Note!**



For further details, refer to the "Safety data sheet" of the refrigerant fluid.

---

## **3. Product specification**

---

### **3.1 General description**

---

The product described in this manual is a display cabinet, hereinafter called "cabinet", multiplexable, in standard sizes, whose intended use is to display food sold:

#### **3.1.1 Structural components.**

##### **ERGO100 V.2014**

- *Multiplexable.*
- *Anti-fogging front ventilation.*
- *Potentiometer for fans.*
- *Ventilated refrigeration with evaporator handled in anti-corrosion cataphoresis.*
- *Refrigerator compartments stainless-steel scratchproof work surface.*
- *Satin-finished steel display surface.*
- *Paper holder.*
- *Thermostatic refrigeration valve.*
- *Condensate collection tank (optional).*
- *Binding clamp (cabinet without refrigeration unit).*
- *Top shelf in painted aluminium.*
- *Cabinet lighting with lamp protection.*
- *Ventilated defrosting with compressor block.*
- *Personalised front.*
- *Perimetrical bumper skirting.*

##### **ERGO 200 V.2014**

- *Multiplexable.*
- *Anti-fogging front ventilation.*
- *Potentiometer for fans.*
- *Ventilated refrigeration with evaporator handled in anti-corrosion cataphoresis.*
- *304 stainless-steel scratchproof work surface.*
- *Satin-finished steel display surface.*
- *Paper holder.*
- *Thermostatic refrigeration valve.*
- *Condensate collection tank (optional).*
- *Binding clamp (cabinet without refrigeration unit).*
- *Top shelf in painted aluminium.*
- *Cabinet lighting with lamp protection.*
- *Ventilated defrosting with compressor block.*
- *Personalised front.*
- *Perimetrical bumper skirting.*

### **ERGO 300 V.2014 (PASTRY CABINET)**

- *Multiplexable.*
- *Front ventilation (for demisting).*
- *Thermostatic valve.*
- *Ventilated refrigeration with pre-painted evaporator.*
- *Condensate collection tank (optional).*
- *With removable refrigerated drawer.*
- *Binding clamp (cabinet without refrigeration unit).*
- *Refrigerated bottom shelf.*
- *Top shelf in painted aluminium.*
- *Top shelf without refrigeration and without lighting.*
- *Cabinet lighting with lamp protection.*
- *Stainless steel scratchproof working surface.*
- *Ventilated defrosting with compressor stop.*
- *Cream-painted display shelf.*
- *Potentiometer for the regulation of the fan speed.*
- *Personalised front.*
- *Perimetrical bumper skirting.*

### **ERGO 310 V.2014 (BREAD)**

- *Multiplexable.*
- *Multiplexable with ER300 through special fix partition panel.*
- *Top shelf without refrigeration and without lighting.*
- *Stainless steel scratchproof working surface.*
- *Inclined display surface made of creamcolour laminate.*
- *Paper holder.*
- *Top shelf in painted aluminium.*
- *Cabinet lighting with lamp protection.*
- *Personalised front.*
- *Perimetrical bumper skirting*

### **ERGO 500 V.2014 (FISH)**

- *Multiplexable.*
- *Anti-fogging front ventilation.*
- *Static refrigeration with refrigerated base.*
- *Stainless steel work surface.*
- *Stainless-steel unit interior.*
- *Paper holder.*
- *R404a thermostatic refrigeration valve.*
- *Condensate collection tank (optional).*
- *Binding clamp (cabinet without refrigeration unit).*
- *Top shelf in painted aluminium.*
- *Cabinet lighting with lamp protection.*
- *Defrosting with compressor block.*
- *Personalised front.*
- *Perimetrical bumper skirting.*

### **ERGO 400-410 V.2014**

- *Multiplexable to all other Ergo versions with flat, mirrored endwalls.*
- *Food tray heating in bain-marie (ER400) or hot surface versions (ER410).*
- *Heating unit on top part.*
- *Stainless-steel scratchproof work surface.*
- *Stainless-steel unit interior.*
- *Electronic panel.*
- *Top shelf in painted aluminium.*
- *Supplied with ready-fitted cabinet.*
- *Personalised front.*
- *Perimetrical bumper skirting.*

#### **3.1.2 Control system**

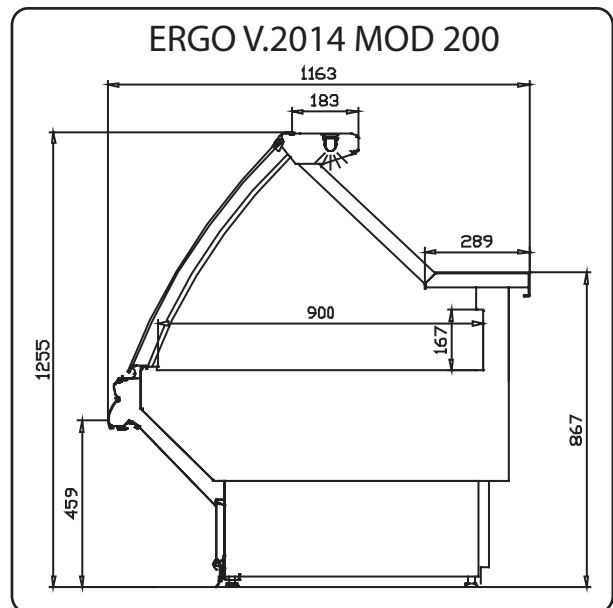
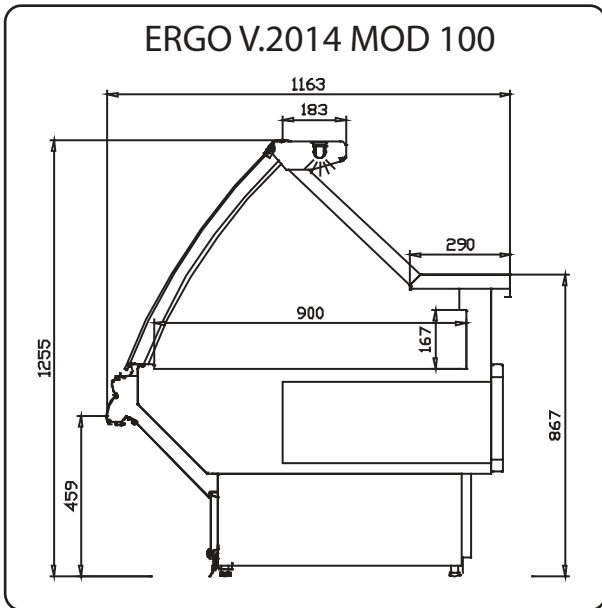
It is performed through control units.

For specific instructions on its use, refer to the enclosed "**Control unit instructions for use**".

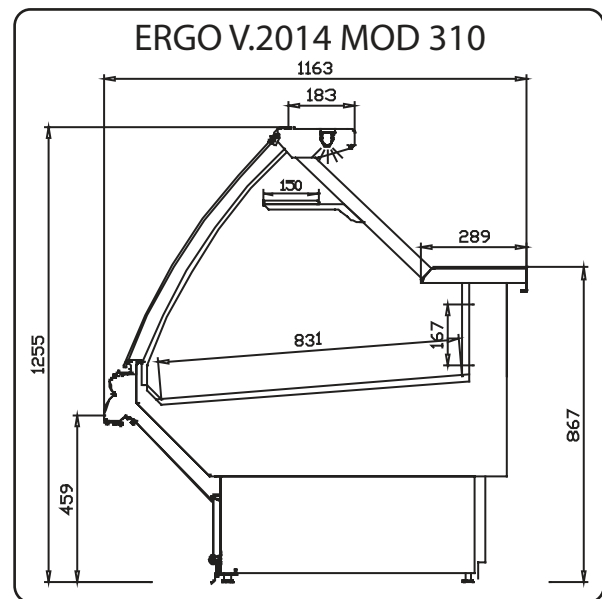
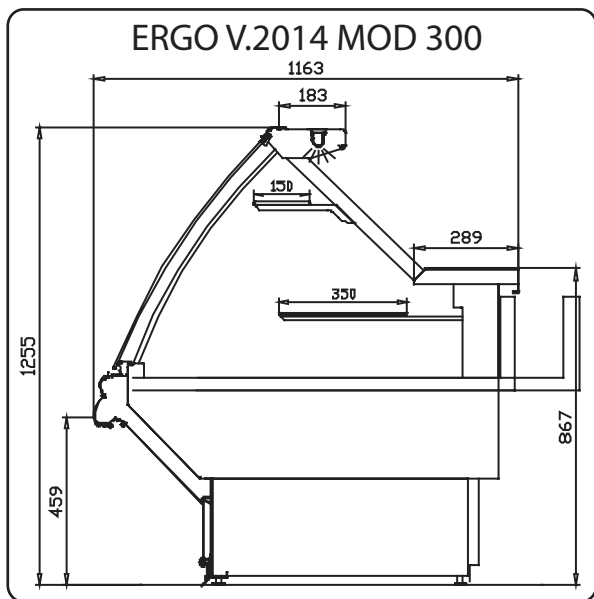
### 3.2 Technical characteristics

In this manual all dimensions in the technical drawings are given in millimeters (mm).

#### 3.2.1 Dimensions



**Fig. 1**



**Fig. 2**

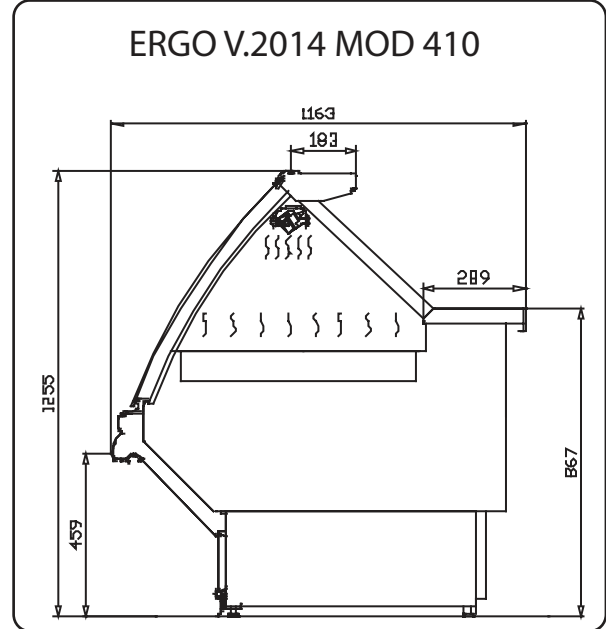
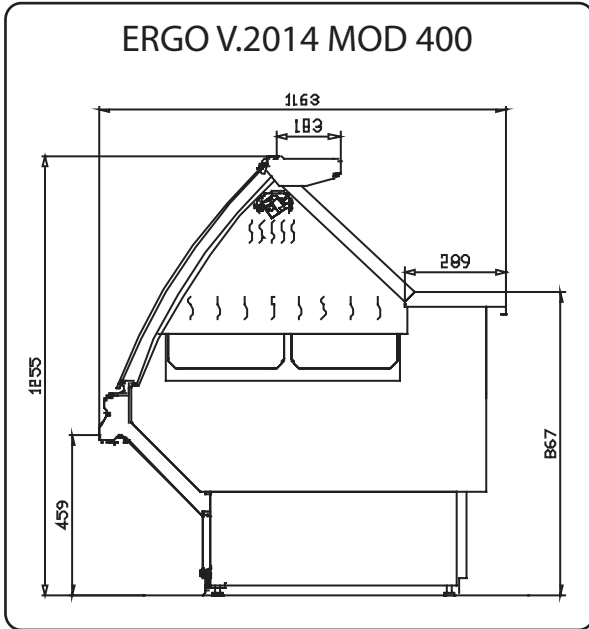


Fig. 3

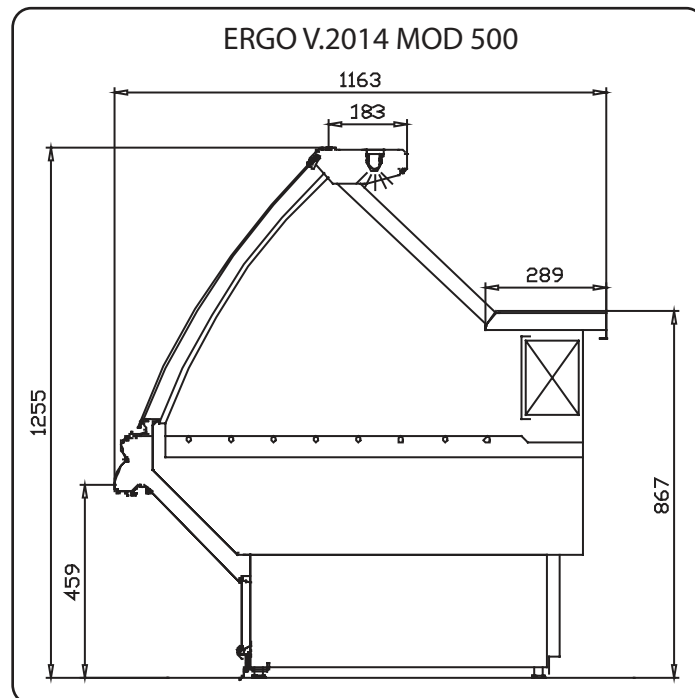
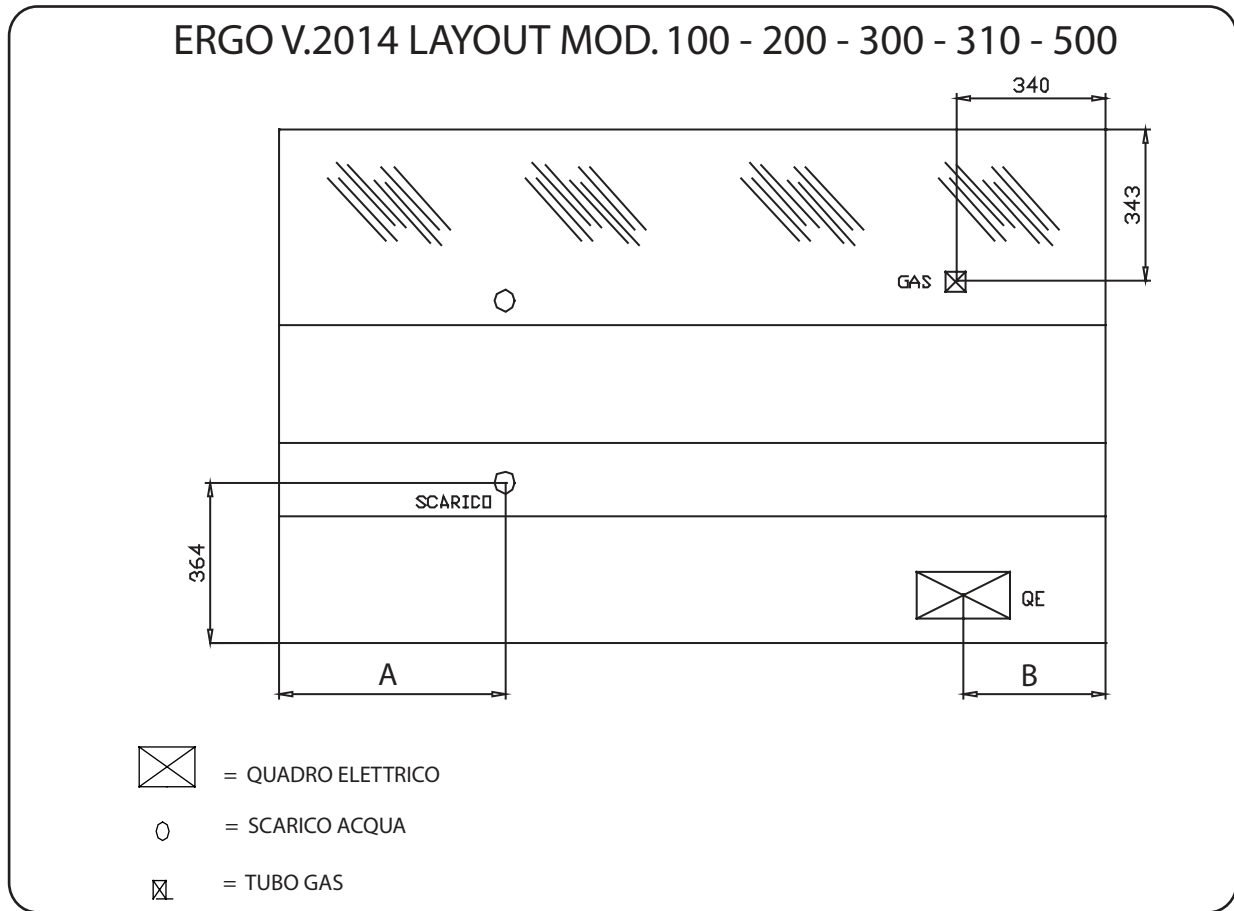


Fig. 4

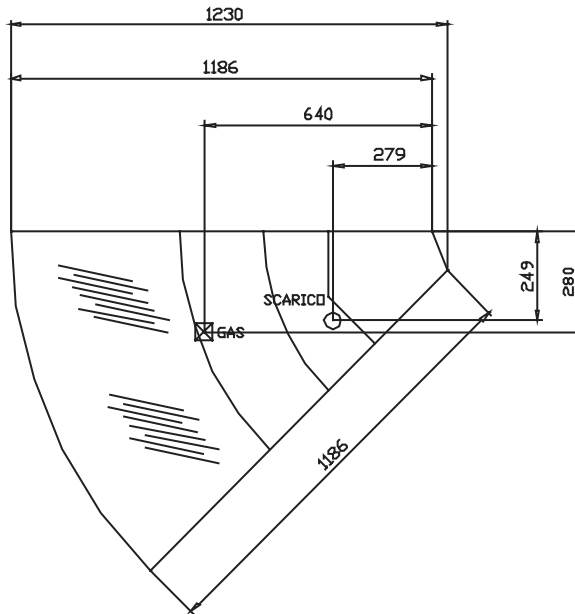
**3.2.2 Lay-out**



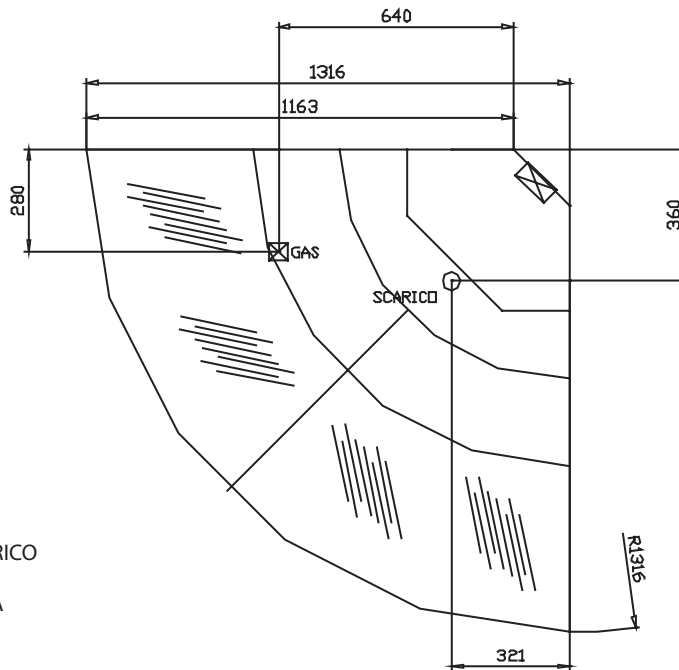
| <b>LENGHT BANK</b> | <b>A</b> | <b>B</b> |
|--------------------|----------|----------|
| 937                | 153      | 170      |
| 1250               | 196      | 290      |
| 1875               | 512      | 322      |
| 2500               | 620      | 785      |
| 3125               | 1042     | 934      |
| 3750               | 1352     | 897      |

ERGO V.2014 LAYOUT ANGOLI - CORNERS - ANGLES - WINKEL

AA45°



AA90°






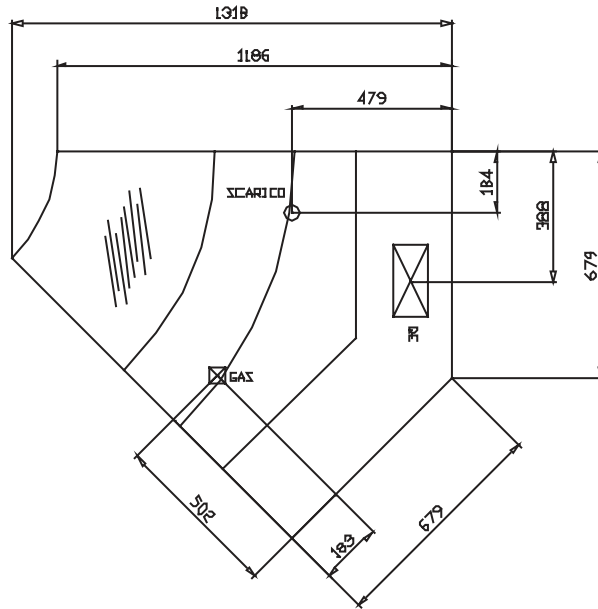
-  = QUADRO ELETTRICO
-  = SCARICO ACQUA
-  = TUBO GAS

Fig. 6

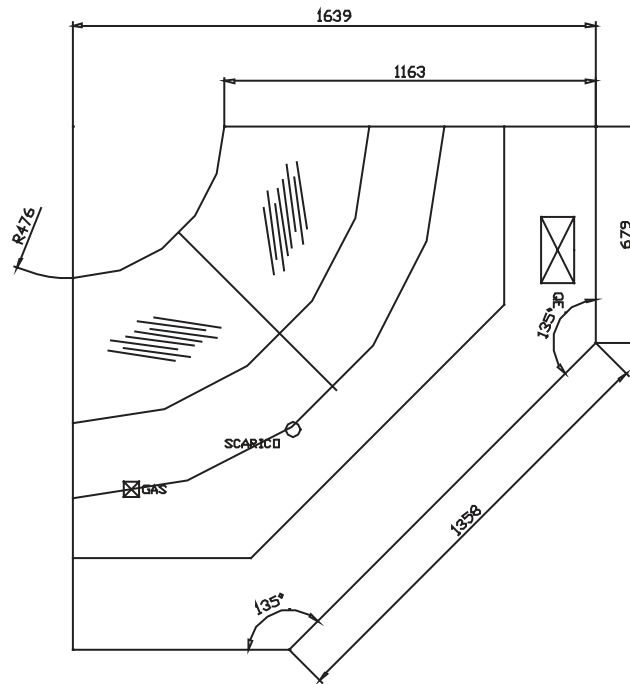





**ERGO V.2014 LAYOUT ANGOLI - CORNERS - ANGLES - WINKEL**

AC45°



AC90°

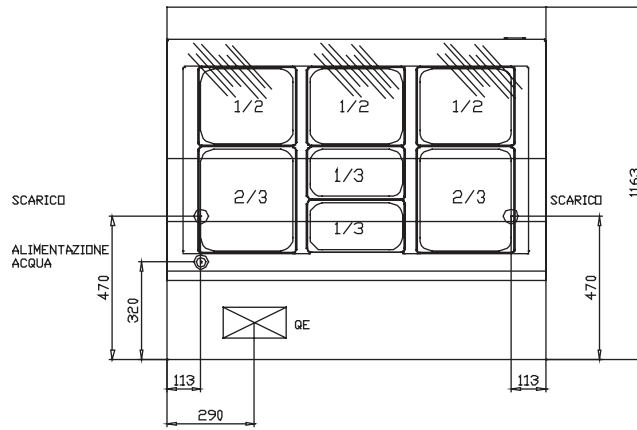


-  = QUADRO ELETTRICO
-  = SCARICO ACQUA
-  = TUBO GAS

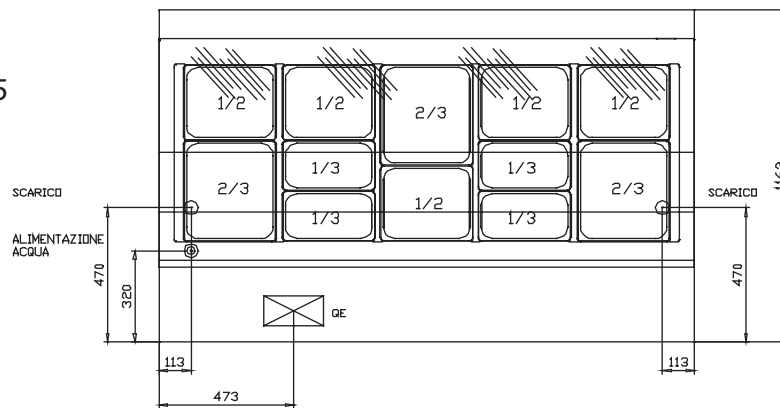
**Fig. 7**

**ERGO V.2014 LAYOUT MOD. 400 410**

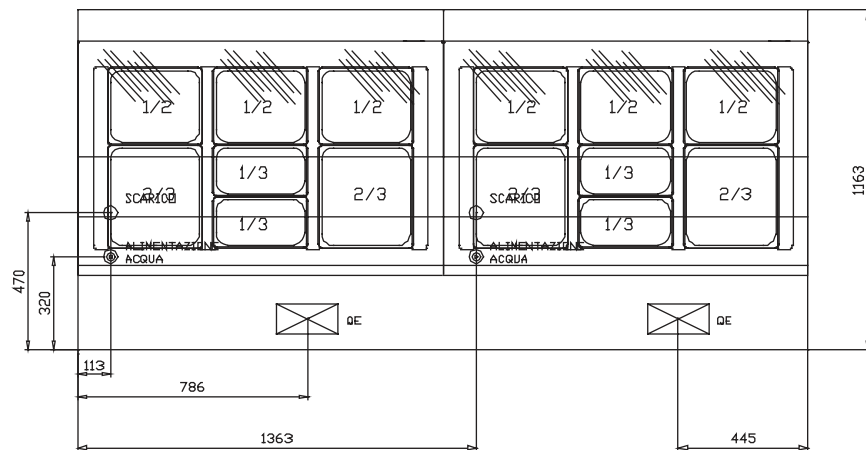
**BANCO 1250**



**BANCO 1875**



**BANCO 2500**



- = QUADRO ELETTRICO
- = SCARICO ACQUA
- = TUBO GAS

**Fig. 8**

### 3.2.3 Weight table

| Cabinet length (mm)                           | 937 | 1250 | 1875 | 2500 | 3125 | 3750 |
|---|-----|------|------|------|------|------|
| Weight (kg) (refrigeration unit not included) | 100 | 125  | 185  | 250  | 310  | 370  |
| Weight (kg) (refrigeration unit not included) | 130 | 160  | 220  | 280  | 340  | 410  |

### 3.2.4 Admissible loads

As for the cabinet admissible loads, refer to the following table:

| COMPONENTS               | LOAD        |
|--------------------------|-------------|
| Top canopies, alluminium | max kg 20/m |
| Top canopies, glass      | max kg 8/m  |
| Intermediate shelves     | max kg 8/m  |
| Display surfaces         | max kg 95/m |

### 3.2.5 Refrigeration system:

As for the refrigerant fluid characteristics, refer to the enclosed "**Refrigerant fluid safety data sheet**".

**Unless requested by the Customer, our cabinets use as refrigerant "R404 a".**

## 3.3 Noise level

Tests performed by the Manufacturer have shown that the noise level ranges from 55 to 57 dBA in compliance with the EU Directive no. 89/392/EEC.

Noise level depends also on room temperature and, as for cabinets "with refrigeration unit", on the condensing unit cleaning level.

## 3.4 Other emissions



**Warning!**

Refrigerant R404a leaks are possible.

## 3.5 Environmental requirements for operation

To maintain the refrigerating cabinet in good working conditions check that the cabinet temperature class corresponds to that of the room where the cabinet has been installed (see rating plate).

To maintain in good conditions cabinets provided with a refrigerating unit, act as follows:

- *guarantee air exchange in the room, even at floor level, also when the sales outlet is closed;*
- *do not obstruct the condensing unit air outlets by placing products or materials around the cabinet.*

In case of cabinets "without refrigeration unit", act as follows:

- *locate the remote condensing unit in a place sheltered from the atmospheric agents.*

In any case, act as follows:

- *install the cabinet avoiding exposure to direct sunlight and to any other source of heat such as high-intensity incandescent lighting, ovens or heat-emitting bodies such as radiators;*
- *position the cabinet away from doors, windows, air-conditioning outlets to avoid air flows exceeding 0.2 m/s.*

**Note!**



A room temperature rising and/or a lack of air to the condensing unit not only increases energy consumption but also reduces the cabinet technical performances and may lead to the deterioration of displayed products.

The cabinet operating room temperature is 25 °C ± 1 °C. The environment humidity shall be 60% ± 3%.

**3.6 Description of residual risks**

**Warning!**

**DANGER OF CUTTING**



When cleaning the cabinet tray, after having removed the display shelves, be careful not to injure yourself on the evaporator fins as they may be sharp due to their reduced thickness.

When cleaning the condensing unit of cabinets provided "with a refrigerating unit", be careful not to injure yourself on the condensing unit fins, as they may be sharp due to their reduced thickness.



**PERSONAL PROTECTIVE EQUIPMENT**

It is compulsory to wear protective gloves when performing the above mentioned cleaning operations.



**Warning!**

**DANGER OF BURNS**

In case of cabinets provided with electric defrosting, be careful not to get burnt by the heater, as this may still be hot.

In case of infrared lamp heated cabinets, be careful no to get burnt by hot parts.



**Warning!**

**DANGER OF CRUSHING**

Cabinet front glasses open by means of piston system. Pistons act as a lifting back-up and prevent the glass from accidental and unexpected falling.

To avoid danger of crushing, check periodically the system efficiency and check if the effort required to lift the glass is increasing, as this will indicate a reduced efficiency of the lifting system.

**Warning!**

**DANGER OF GLASS BREAKING**



All movable glasses are hardened and, if broken, fragment in pieces not longer than 3cm, thus reducing the risk of damaging people.

During the normal use of the cabinet glasses are lowered, thus avoiding any danger of breaking due to glass falling.

To store goods and for cleaning purpose glasses are lifted and kept open thanks to the lifting system.

**3.7 Specific protections**

Normally, the refrigeration system components and the control panel are not accessible. They are sheltered by means of panels placed on the cabinet rear side.



**Prohibition!**

Except when special maintenance is performed, it is forbidden to remove the panels or use the cabinets when the panels have been removed or are open.

**4. Instructions for commissioning**

**4.1 Transport, handling and positioning**

**4.1.1 Precautions to be taken upon receipt of the product**

The Manufacturer supplies the cabinet ex-works. Before delivery to the carrier, the material, subject matter of the supply contract, shall be carefully inspected by the Manufacturer.

The Manufacturer cannot be held responsible for missing parts or damage to parts that might occur after delivery to the carrier.



**Note!**

**The cabinet components are usually packed; non-packed components have to be covered during transport.**

**All loose components that might move during transport must be firmly secured.**



**Note!**

Upon receipt of the cabinet, the Customer shall act as follows:

**Check that the supplied material corresponds to the order specifications.**

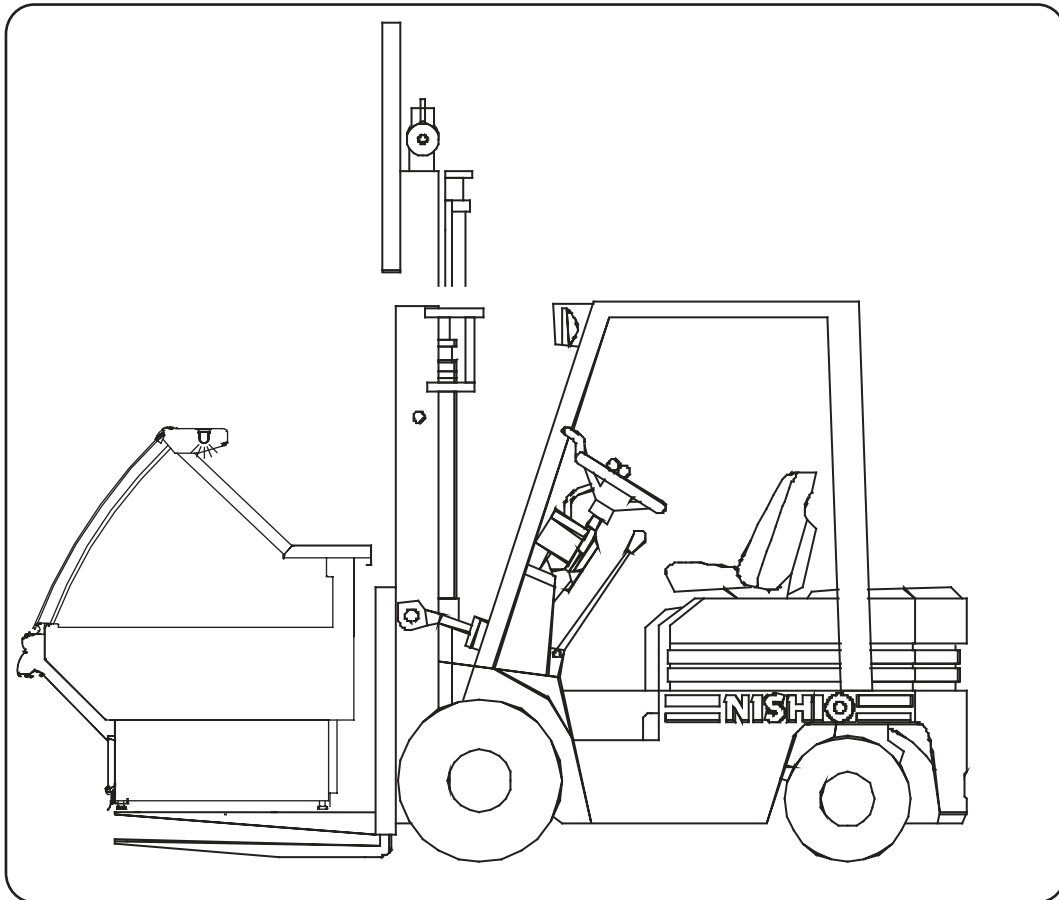
**Check that the cabinet has not been damaged during transport, that the packaging, if any, has not been tampered with and that no part is missing.**

**In case of damage or missing parts, immediately inform the carrier and the Manufacturer producing photographic proof.**

### 4.1.2 Handling and positioning

**Unless otherwise specified, the Customer is responsible for the above mentioned operations.**

To handle the cabinet use a forklift truck of suitable capacity. Refer to the gripping-lifting areas shown in the picture below.



**Fig. 9** Movimentation



**Note!**

It is recommended to move the cabinet only by means of a pallet.

**Check the correct balancing of the cabinet before lifting it completely.**

**Lifting has to be smooth (avoid jerks and jolts).**

Make sure that the cabinet has been positioned completely flat. If necessary, adjust the feet screws and check the position of the cabinet with a spirit level. The cabinet must be placed on a completely flat surface to ensure correct operation, to drain any condensing water and to avoid noisy vibrations from the motor.

In case of cabinets provided with a condensate collection tank, make sure that the collection tank has been positioned so that to allow the connection of the relative drainage pipe to the hydraulic system.

---

## **4.2 Unpacking and disposal of packaging materials**

---

**Unless otherwise specified, the Customer is responsible for the operations mentioned below.**

Remove the packaging only after having positioned the unit.

Packaging must be disposed of in compliance with the laws in force.

### 4.3 Assembly

Unless otherwise specified, the Customer is responsible for the operations mentioned below.

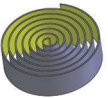






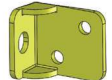





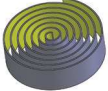






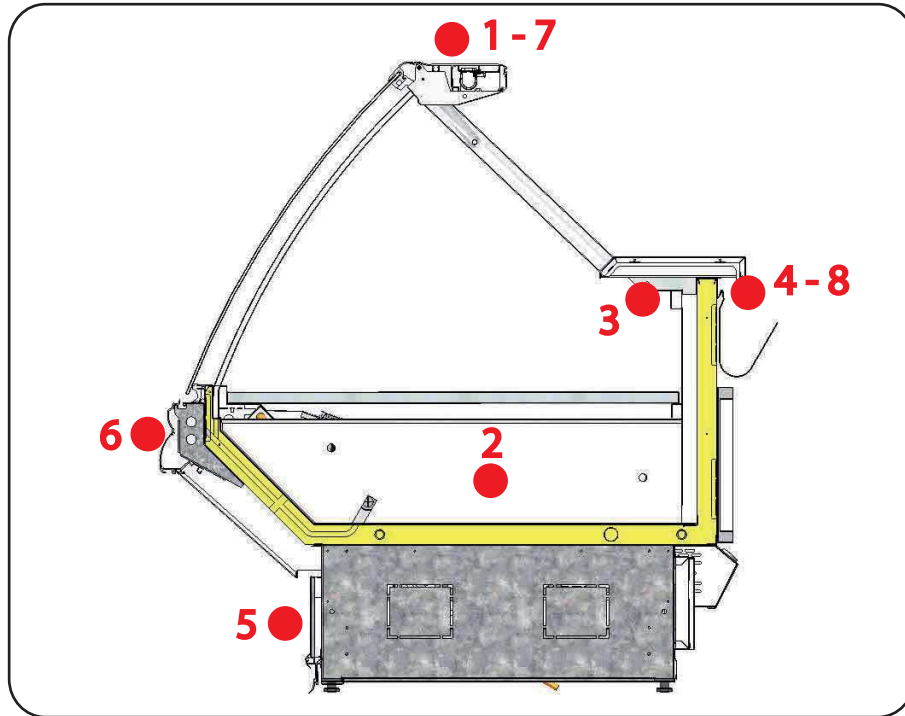
| CANALIZZAZIONE TRA BANCO E BANCO - MULTIPLEXATION BETWEEN CABINET AND CABINET -<br>CANALISATION VITRINE ET VITRINE - ZUSAMMENBAUSATZ ZWISCHEN THEKE UND THEKE   |  |   |   |
|---|--|---|---|
|  <b>SPUGNA ADESIVA</b><br><b>2 PZ</b>  | <b>RIF. 1</b> C50001970<br>SPINA D. 4 X 40 ZN<br> <b>6 PZ</b>     | <b>RIF. 2</b> C50001040<br>VITE M6 X 100 TE ZN<br> <b>5 PZ</b>       | <b>RIF. 3</b> C50001880<br>DADO M6 ZN<br> <b>7 PZ</b>      |
| <b>RIF. 4</b> C50006050<br>VITE M6X 30 TCEI ZN<br> <b>2 PZ</b>   | <b>RIF. 5</b> C70028290<br>COPERTURA CAN<br> <b>1 PZ</b>          | <b>RIF. 6</b> C50003550<br>VITE AF 4,2X13 TC-IC IX<br> <b>16 PZ</b>  |   |
| <b>RIF. 10</b> C70103550<br>ANG CANALIZZ<br> <b>4 PZ</b>   | <b>RIF. 11</b> C50002170<br>ROSETTA ZN X M6<br> <b>10 PZ</b>    | <b>RIF. 12</b> C50003770<br>SPINA D. 5 X 50 ZN<br> <b>2 PZ</b>    | <b>KIT 1</b>  |
| CANALIZZAZIONE BANCO CON CASSA - MULTIPLEXATION BETWEEN CABINET AND ENDWALL FOR CASH BLOCK -<br>CANALISATION ENTRE VITRINE ET JOUE CAISSE - ZUSAMMENBAUSATZ ZWISCHEN THEKE UND SEITENTEIL FÜR KASSENTISCH |  |   |   |
| <b>RIF. 6</b> C50003550<br>VITE AF 4,2X13 TC -IC IX<br> <b>4 PZ</b>  | <b>RIF. 10</b> C70103550<br>ANG CANALIZZ<br> <b>2 PZ</b>        | <b>RIF. 11</b> C50004110<br>VITE AF 4,8X32 TC -IC<br> <b>6 PZ</b>  | <b>KIT 2</b>  |
| CANALIZZAZIONE BANCO CON SPALLA PIATTA - MULTIPLEXATION BETWEEN CABINET WITH FLAT ENDWALL -<br>CANALISATION ENTRE VITRINE ET JOUE PLATE - ZUSAMMENBAUSATZ ZWISCHEN THEKE MIT FLACHEN SEITENTEIL           |  |   |   |
| <b>SPUGNA ADESIVA</b><br> <b>1 PZ</b>  | <b>RIF. 7</b> C50001730<br>VITE AF 4,8X60 TC-IC<br> <b>4 PZ</b> | <b>RIF. 6</b> C50003550<br>VITE AF 4,2X13 TC-IC IX<br> <b>4 PZ</b> | <b>RIF. 11</b> C70103550<br>ANG CANALIZZ<br> <b>2 PZ</b> |
| <b>RIF. 12</b> C50004110<br>VITE AF 4,8X32 TC -IC<br> <b>2 PZ</b>  | <b>RIF. 9</b> CP0004867<br>SUPP.FIANCO V.SP.5<br> <b>2 PZ</b>   | <b>RIF. 10</b> CP0001528<br>BORCHIA 25X25 M6<br> <b>1 PZ</b>       | <b>FOR VERSION 310 - 400 - 410</b> <b>KIT 3</b>   |

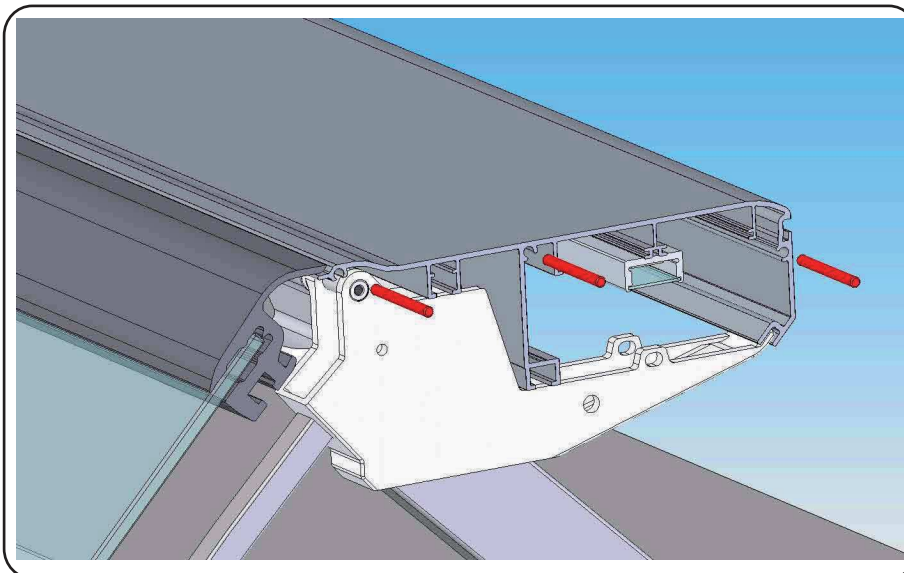


Fig. 10

KIT 1



● 1



RIF. 1 C50001970  
SPINA D. 4 X 40 ZN

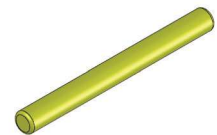
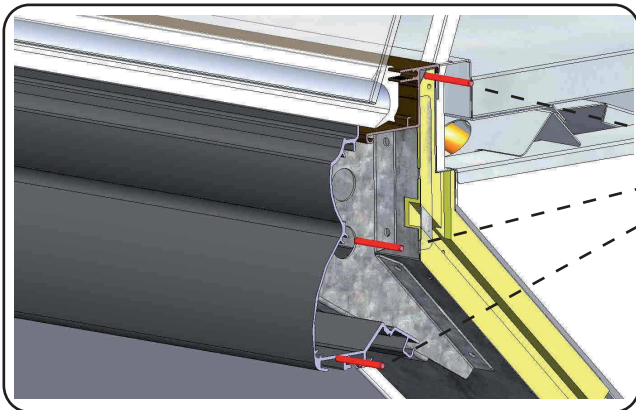
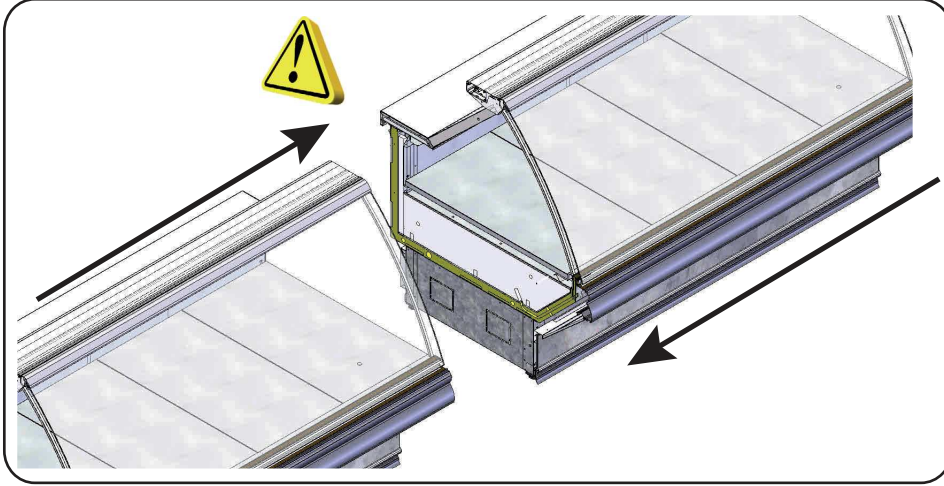


Fig. 11

● 2

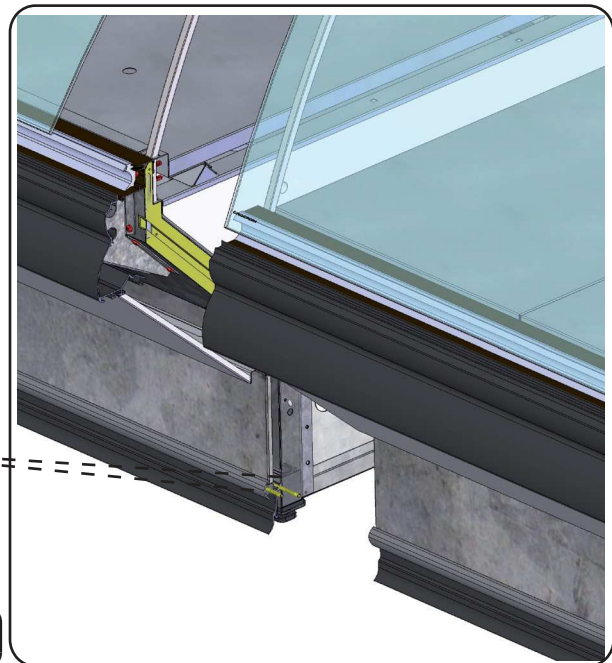


RIF. 1 C50001970  
SPINA D.4 X 40 ZN



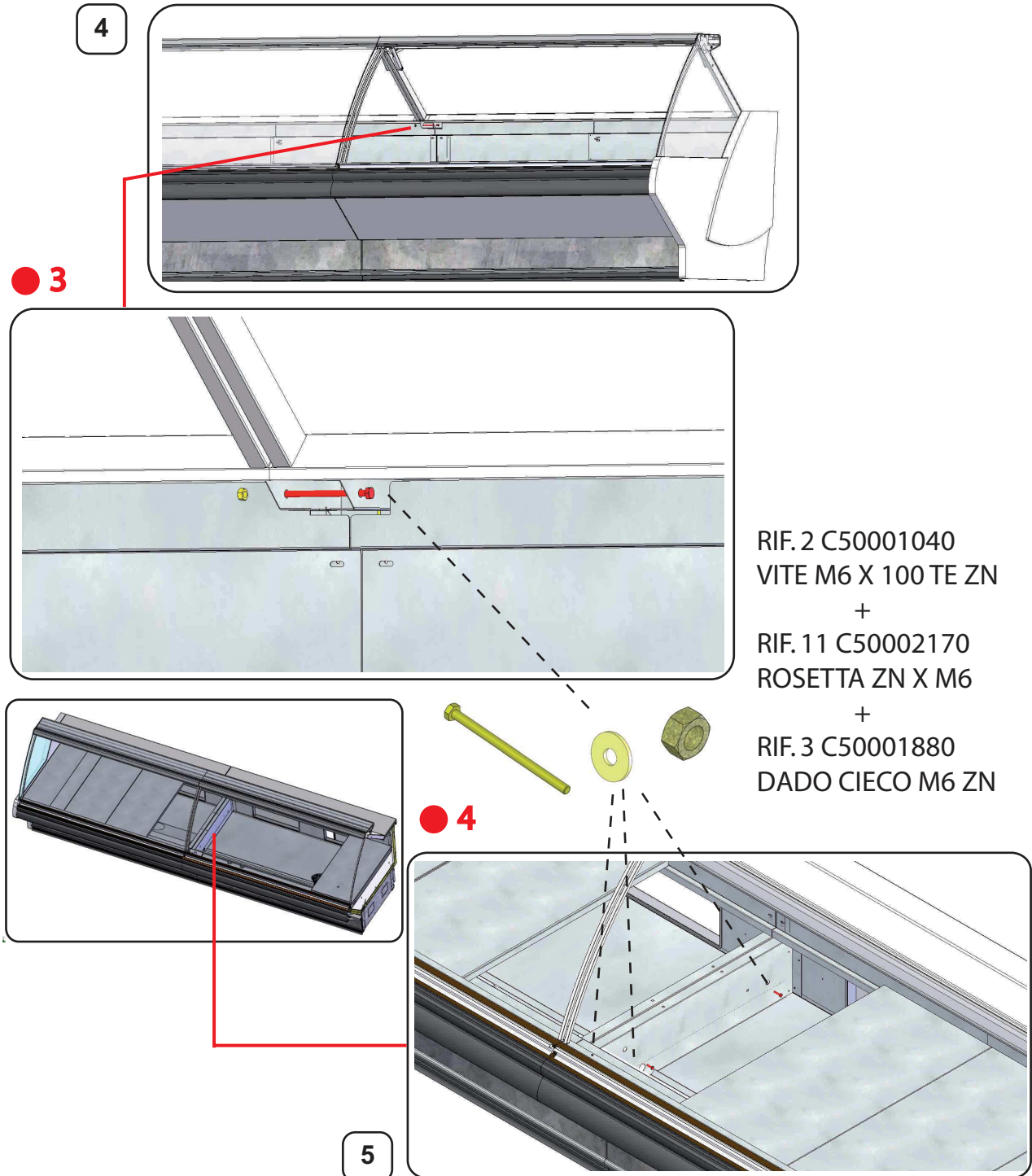
2

RIF.12 C50003770  
SPINA D.5 X 50 ZN

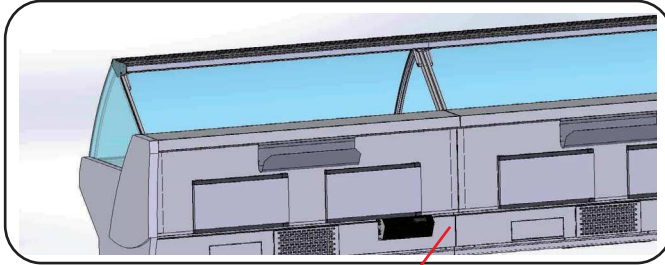


3

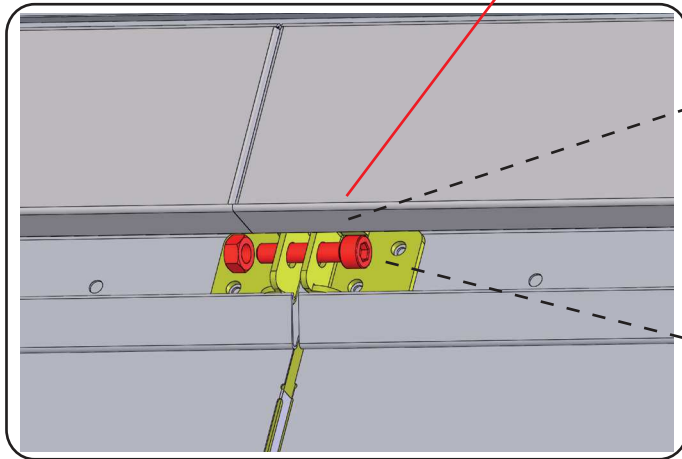
Fig. 12



6  
● 5



RIF. 4 C50006050  
VITE M6X 30 TCEI ZN  
+  
RIF. 3 C50001880  
DADO CIECO M6 ZN

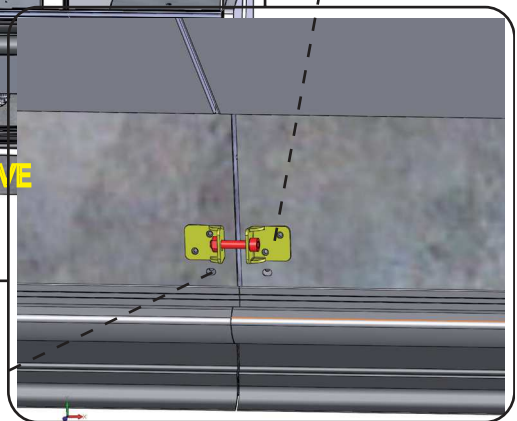
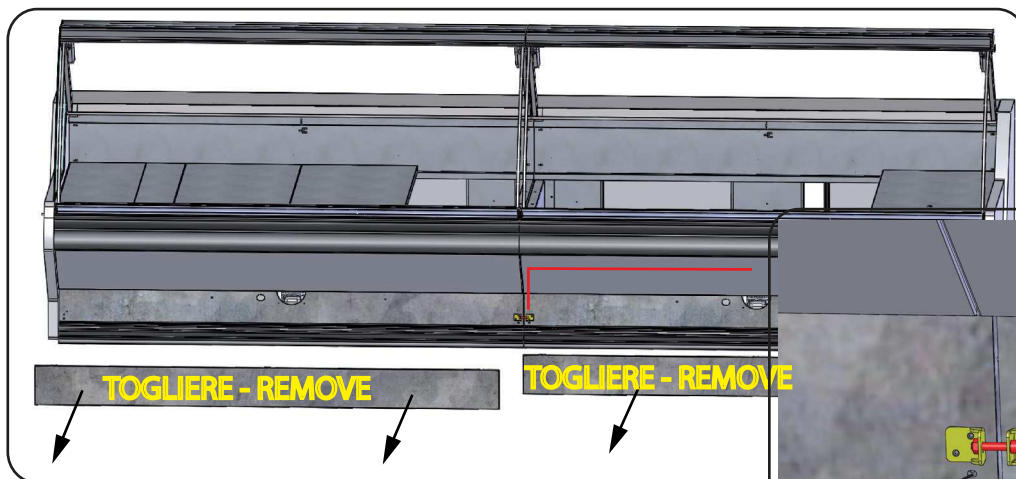


RIF. 10 C70103550  
ANG CANALIZZ

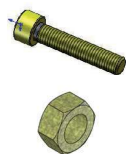


RIF. 6 C50003550  
VITE AF 4,2X13 TC-IC IX

● 6



7



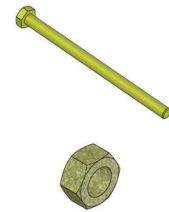
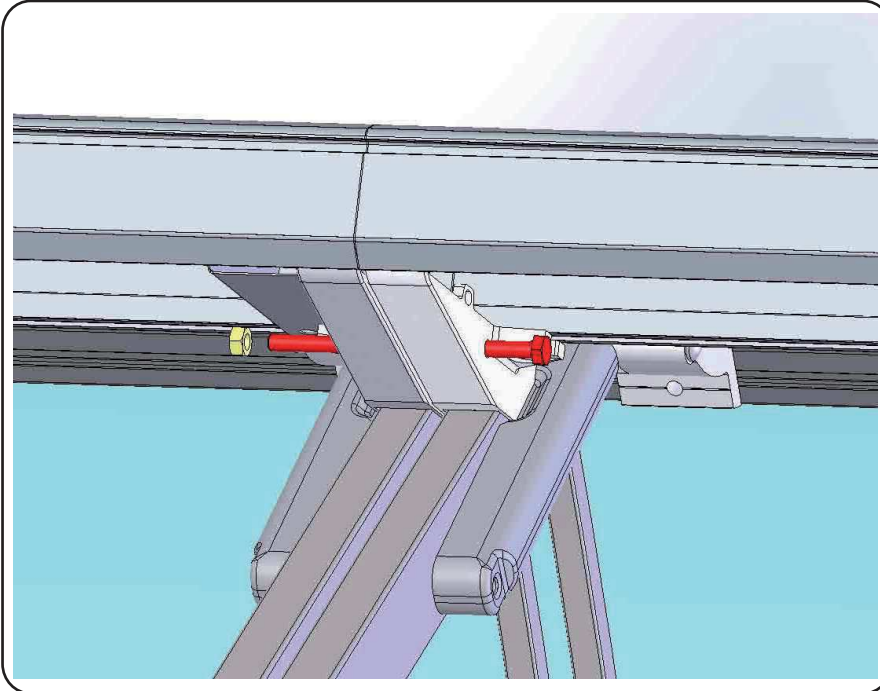
RIF. 4 C50006050  
VITE M6X 30 TCEI ZN  
+  
RIF. 3 C50001880  
DADO CIECO M6 ZN

**Fig. 14**



● 7

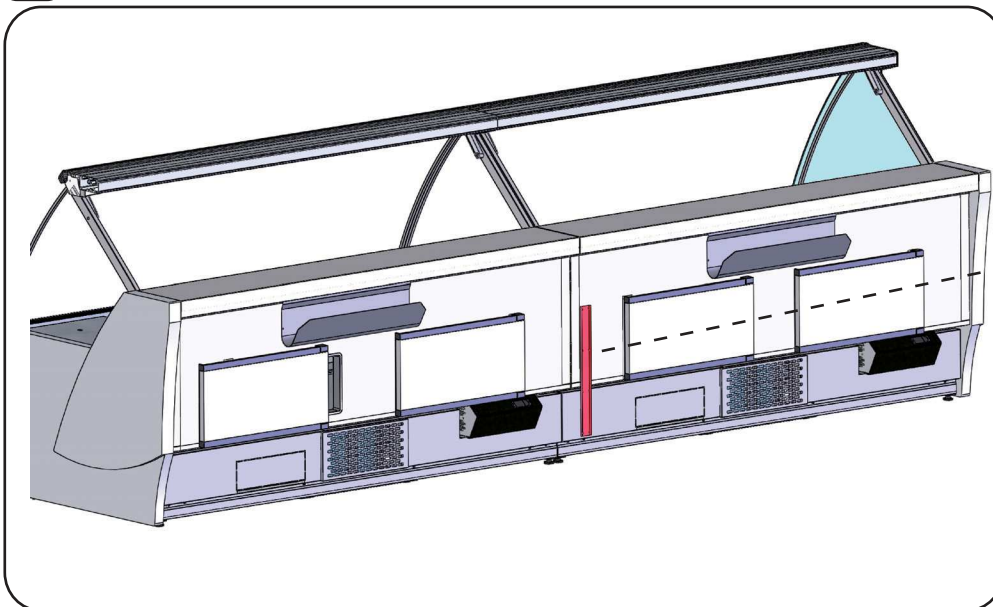
8



RIF. 2 C50001040  
VITE M6 X 100 TE ZN  
+  
RIF. 3 C50001880  
DADO CIECO M6 ZN

9

● 8



RIF. 5 C70028290  
COPERTURA CAN



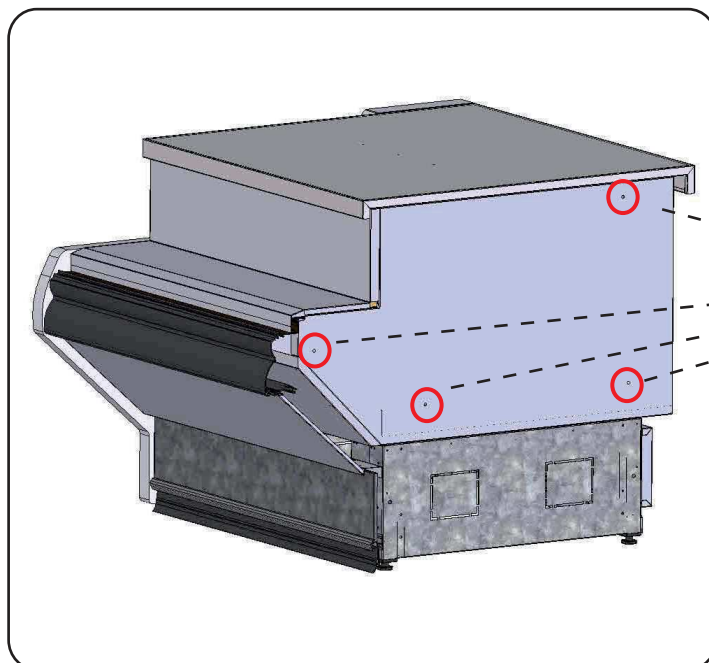
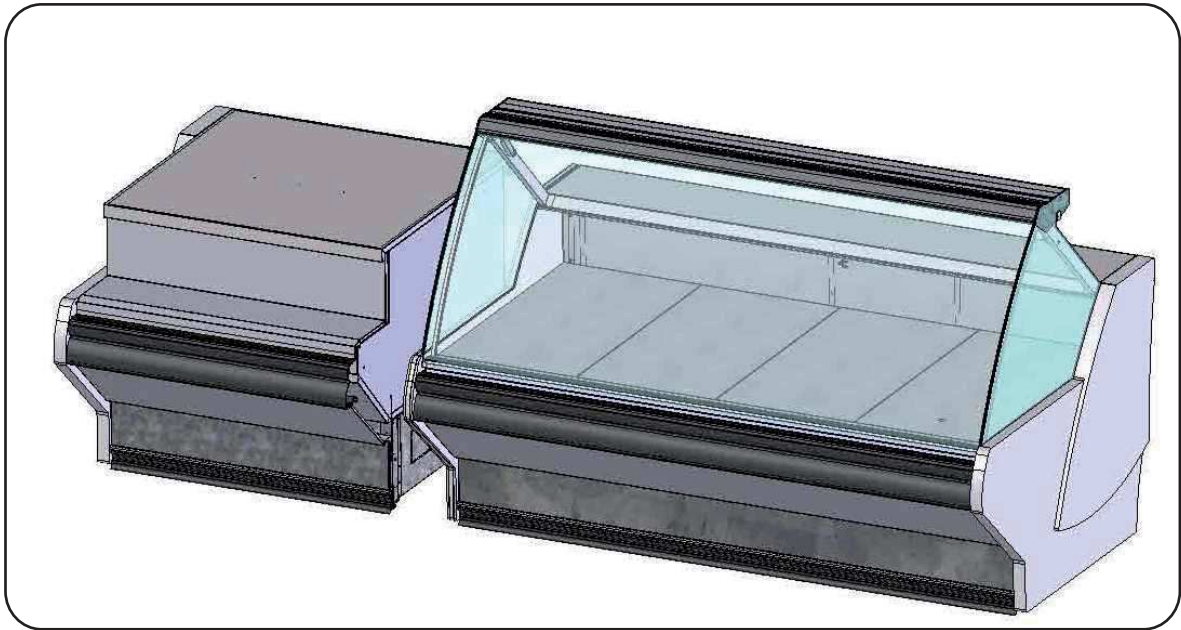
RIF. 6 C50003550  
VITE AF 4,2X13 TC-IC IX



Fig. 15

(IT) CANALIZZAZIONE CON LATERALE CASSA - (GB) MULTIPLEXING WITH BLOCK SECTIONS  
(FR) CANALISATION AVEC CAISSE - (DE) ZUSAMMENBAU MIT KASSENTISCHE

**KIT 2**



1



RIF.11 C50004110  
VITE AF 4,8X32 TC -IC

- FISSAGGIO INTERNO
- INTERNAL FIXING
- FIXATION INTERNE
- BEFESTIGUNG VON INNEN

Fig. 16

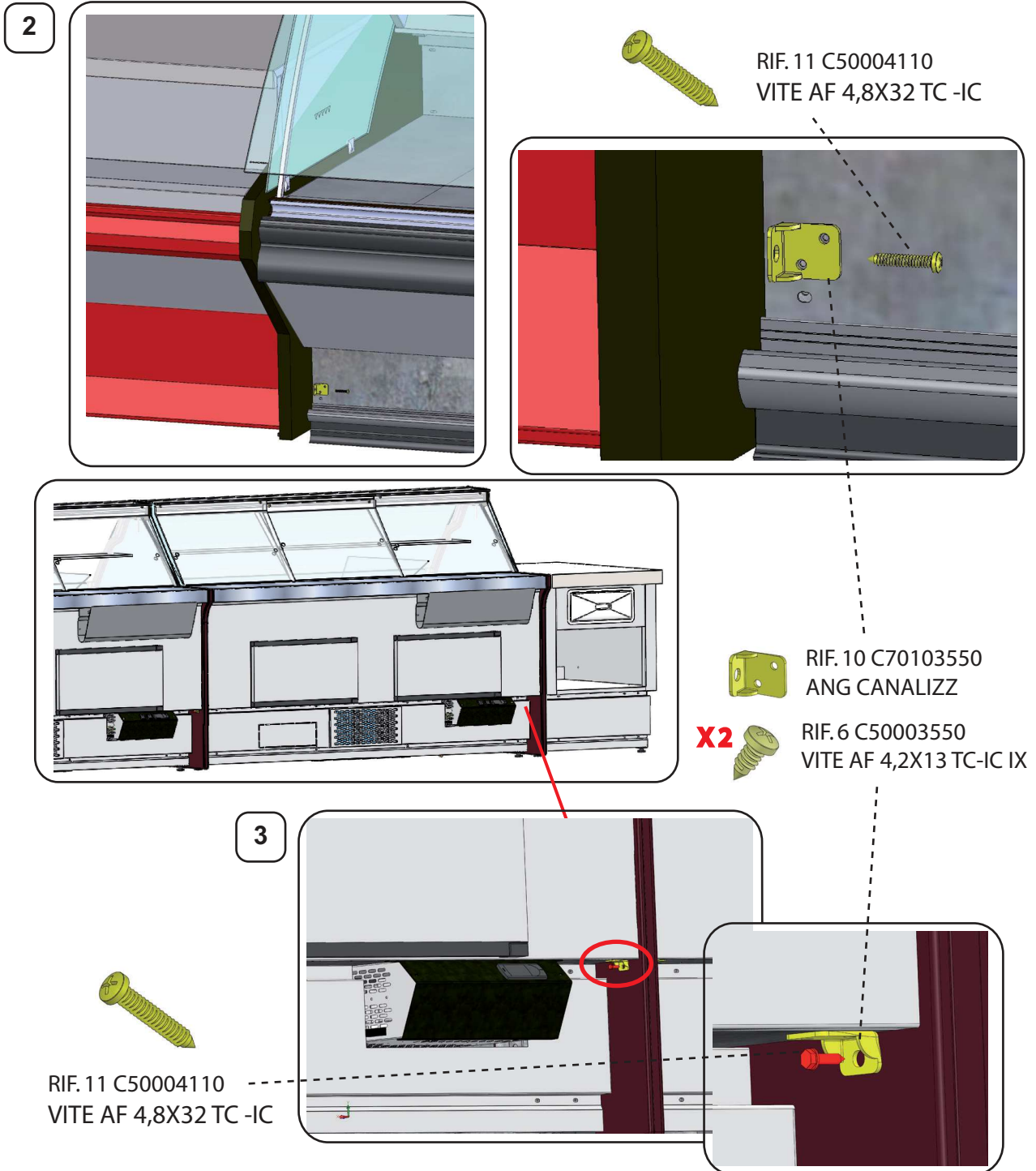
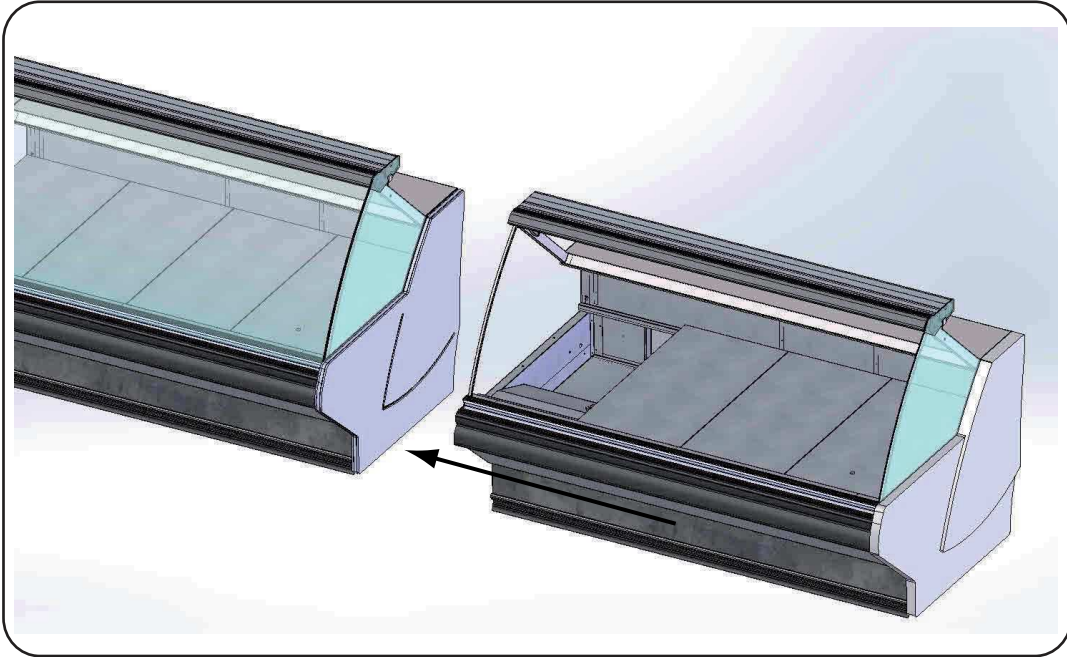
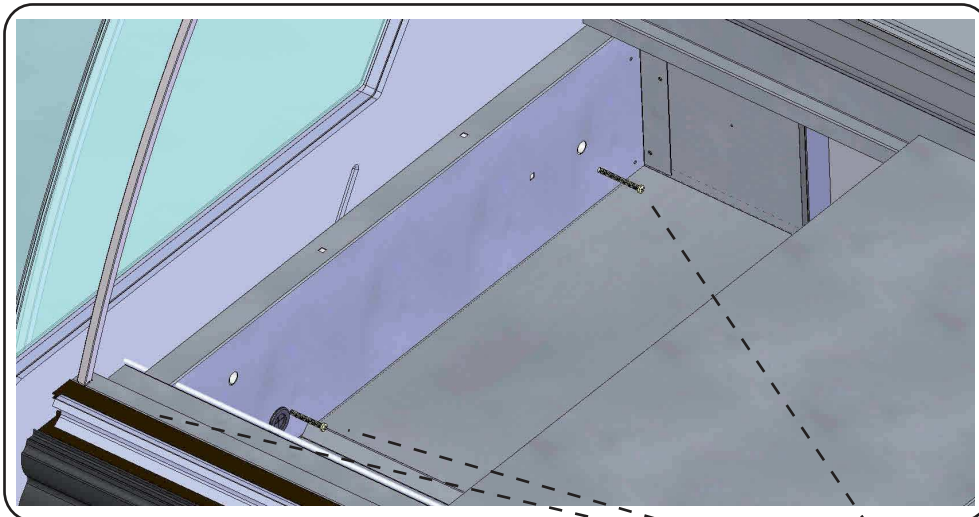


Fig. 17

**KIT 3** CANALIZZAZIONE CON SPALLA PIATTA - MULTIPLEXING WITH FLAT ENDWALL  
CANALISATION AVEC JPUE PLAT - ZUSAMMENBAU MIT FLACHE SEITENTEILE



1

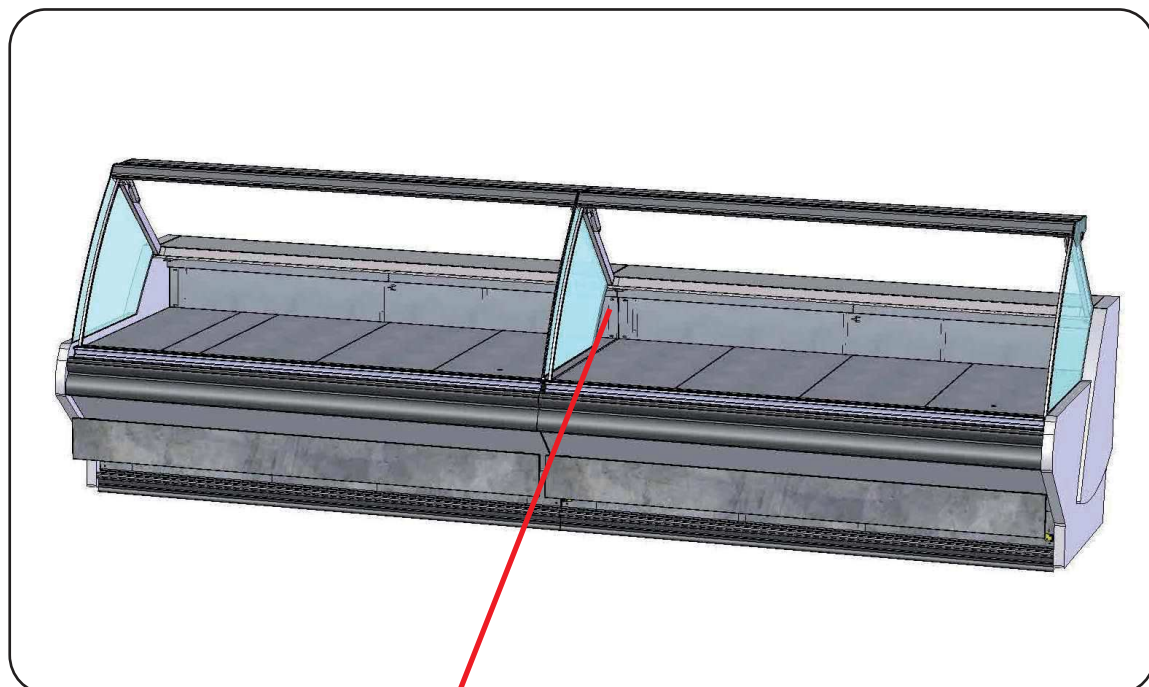


RIF. 7 C50001730  
VITE AF 4,8X60 TC-IC

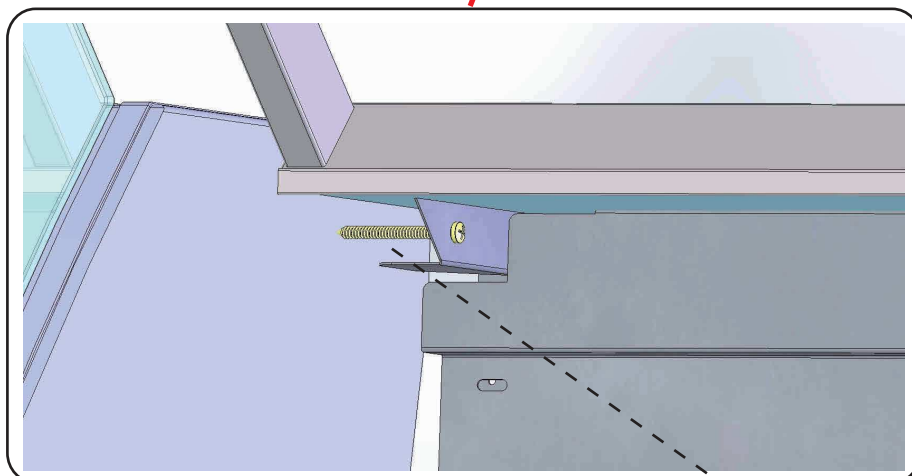


Fig. 18





3



RIF. 7 C50001730  
VITE AF 4,8X60 TC-IC



**Fig. 19**

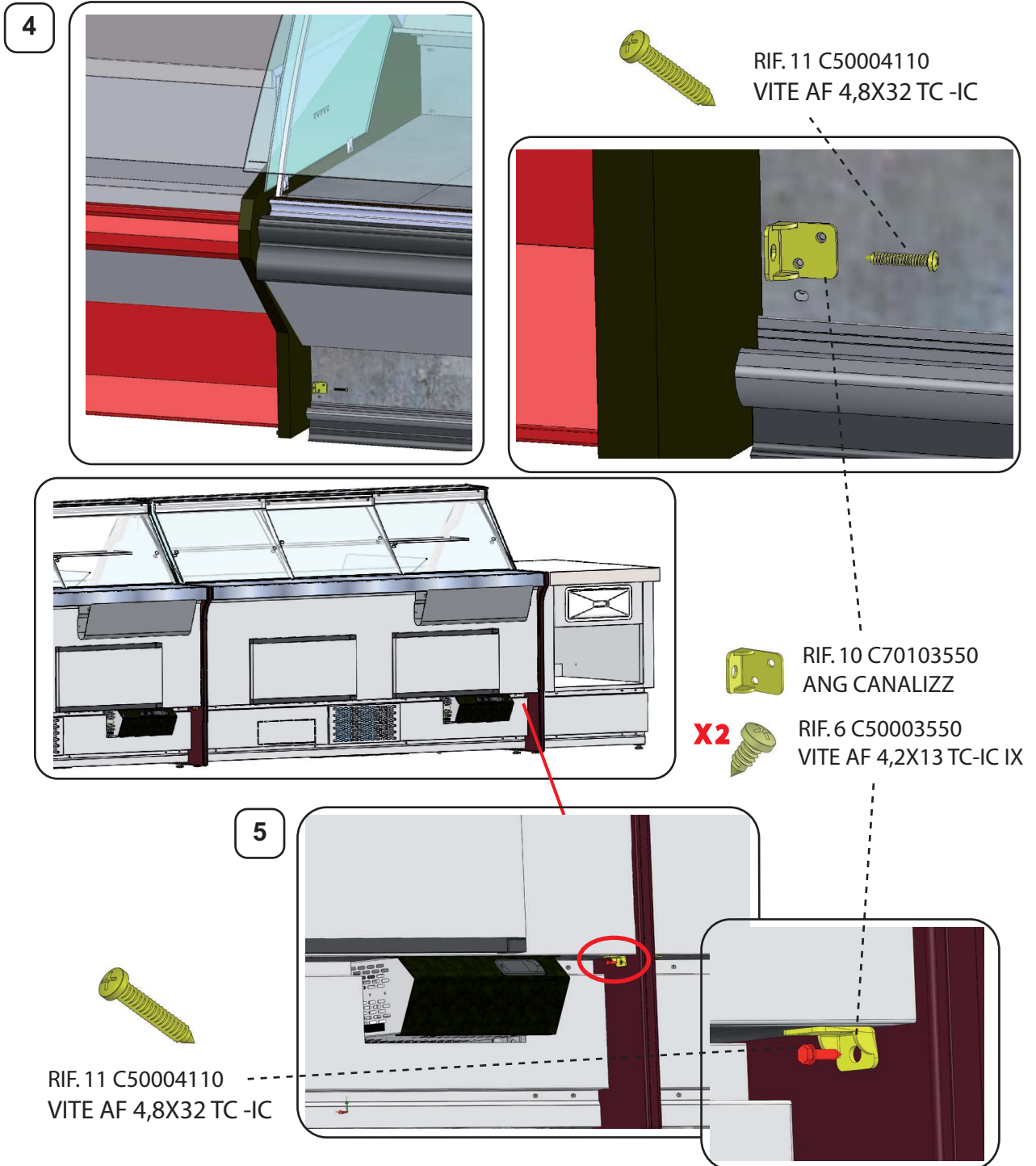
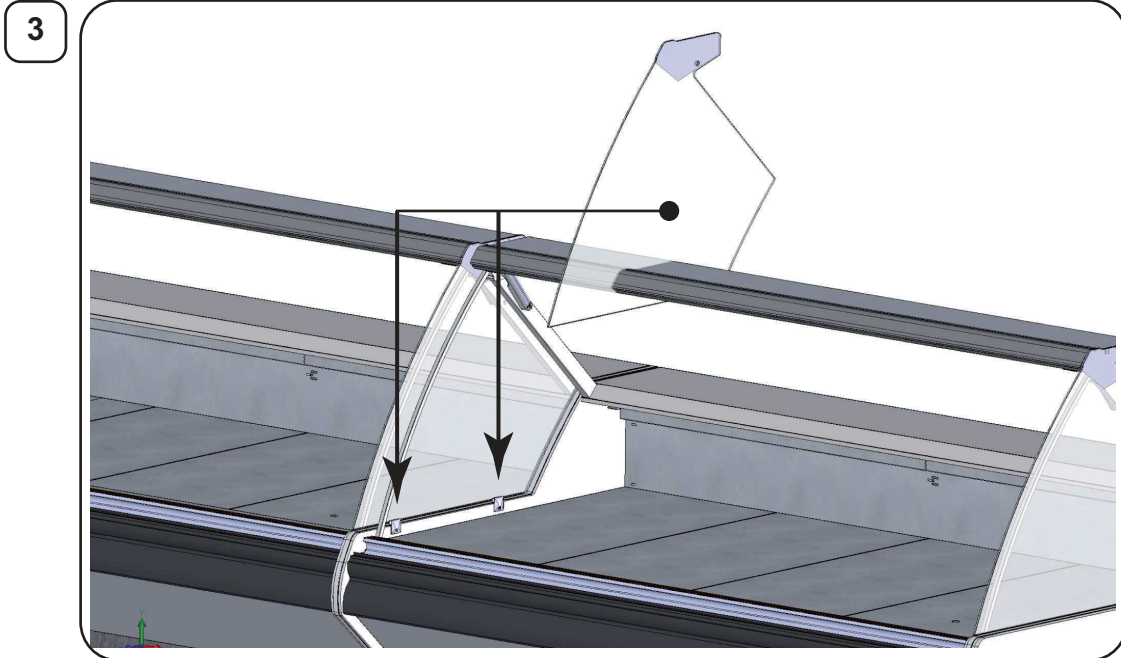
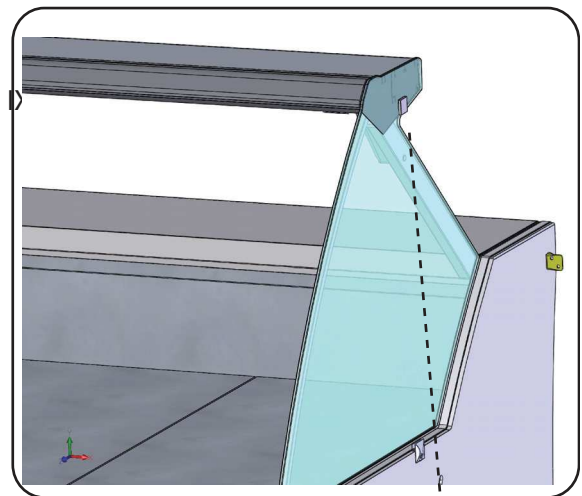
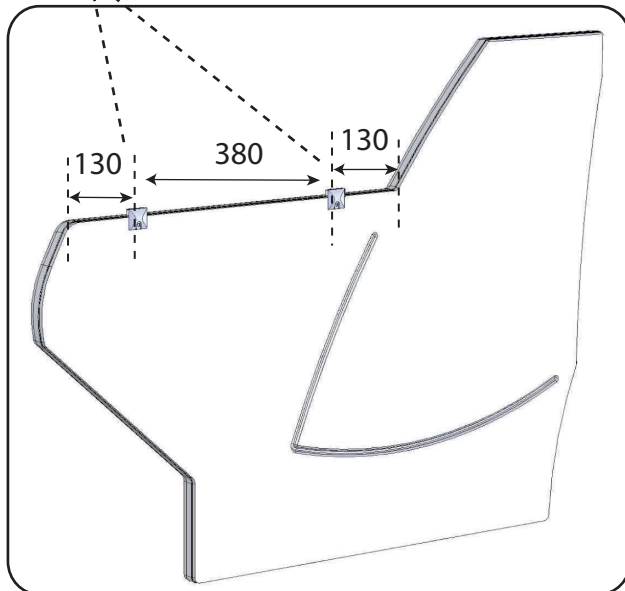


Fig. 20



RIF.8 CP0004867  
SUPP.FIANCO VETRO SP.5  
+  
RIF.6 C50003550 VITE AF 4,2X13 TC-IC



RIF.9 CP0001528  
BORCHIA 25X25 FILETTATA M6

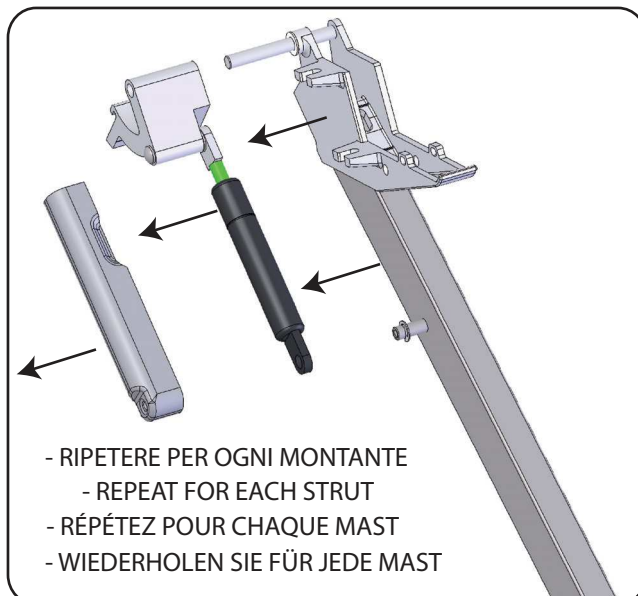
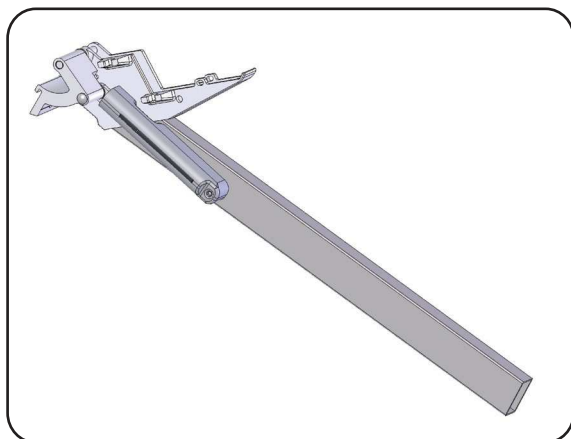
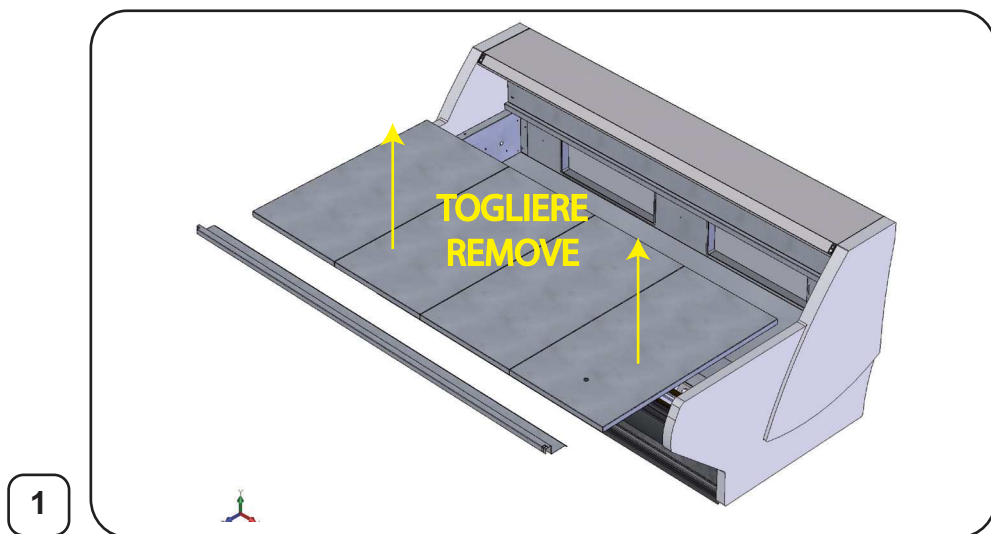


**Fig. 21**

**ASSEMBLY CABINET**

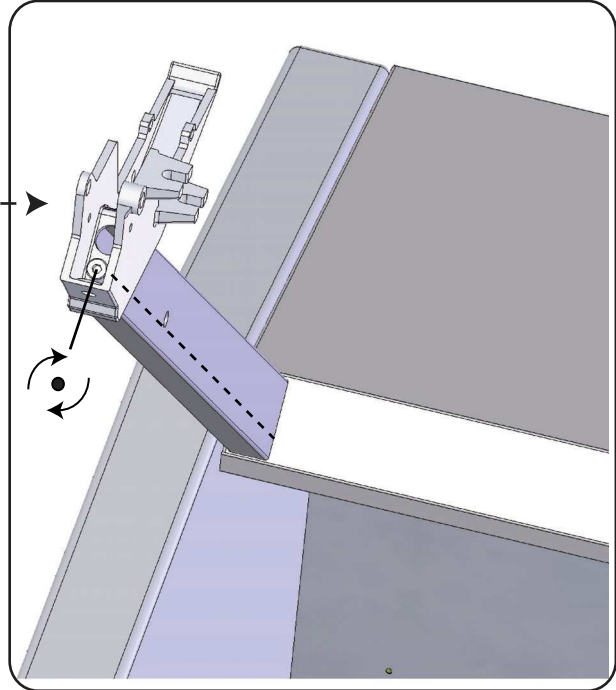
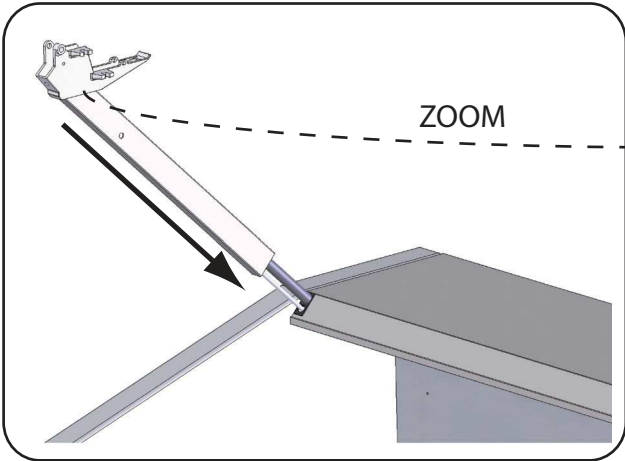
**MONTAGGIO VETRINA (IT) - SHOWCASE ASSEMBLY (GB)  
ASSEMBLEE VITRINE (FR) - MONTAGE SHOWCASE (DE)**

- \* TUTTA LA VITERIA PER IL MONTAGGIO VETRINA VIENE FORNITA, UNITAMENTE AL BANCO SOLO SE RICHIESTO CON VETRINA SMONTATA (IT)
- \* ALL THE SCREWS FOR THE ASSEMBLY OF THE TOP CANOPY ARE SUPPLIED TOGETHER WITH THE CABINET ONLY IF IT IS REQUIRED WITH DISMANTLED TOP CANOPY (GB)
- \* TOUT LA VISSERIE POUR L'ASSEMBLAGE DU SYSTÈME VITRÉ VIENT FOURNI AVEC LA VITRINE, SEULEMENT SUR REQUÊTE AVEC VITRINE DÉMONTÉE (FR)
- \* ALLE SCHRAUBEN FÜR DIE MONTAGE DER VITRINE WIRD NUR BEI BEDARF DER DEMONTIERTEN VITRINE MIT DER THEKE GELIEFERT (DE)

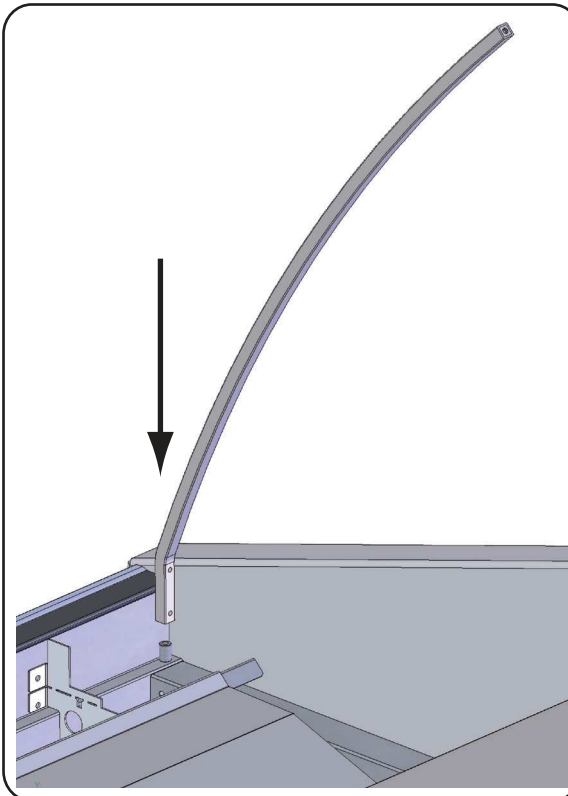


**Fig. 22**

3



4



52000461  
VITE AF 3,9X25 TC -IC

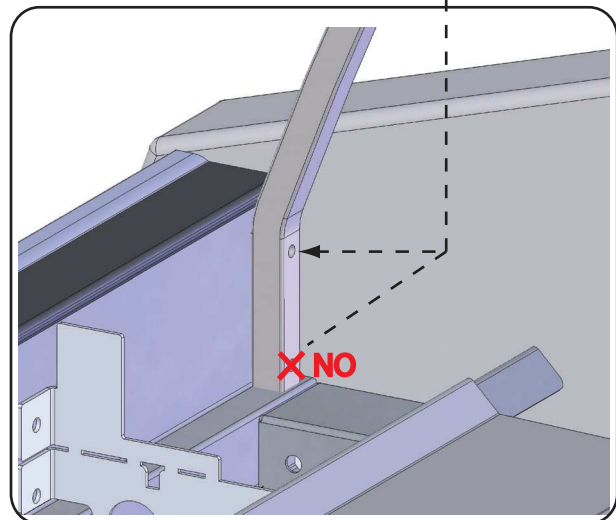
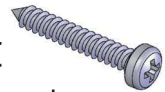
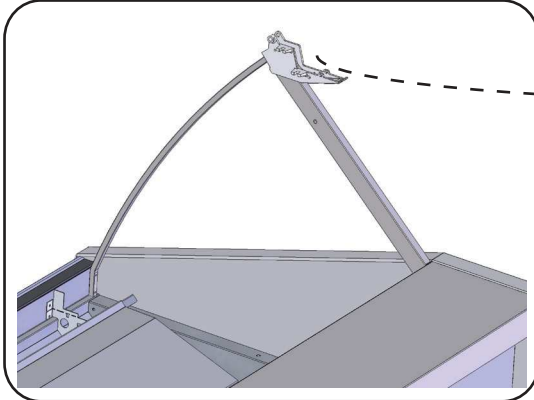
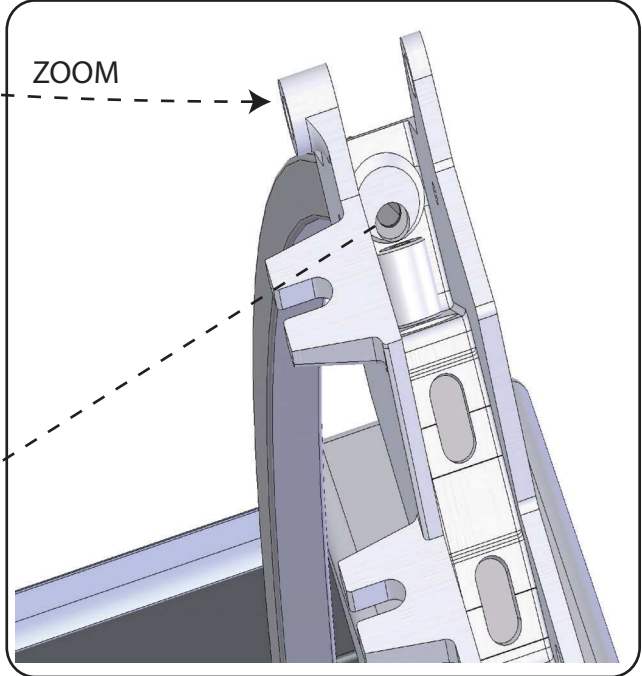


Fig. 23

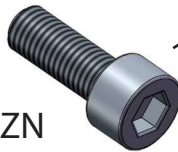
5



ZOOM



C50001980  
VITE M6 X 16 TCEI ZN



6



C50001880  
DADO E M6 ZN

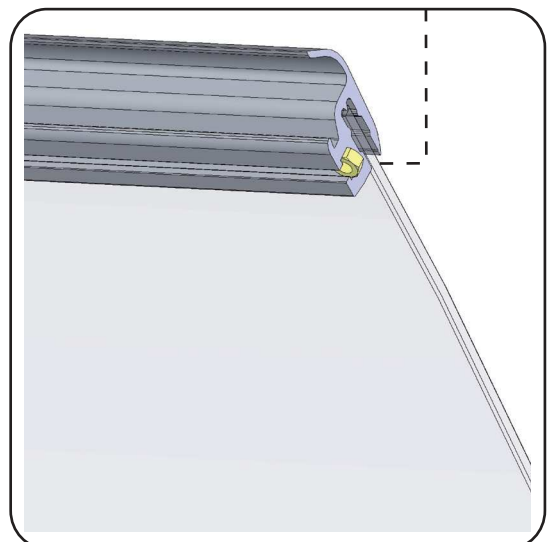
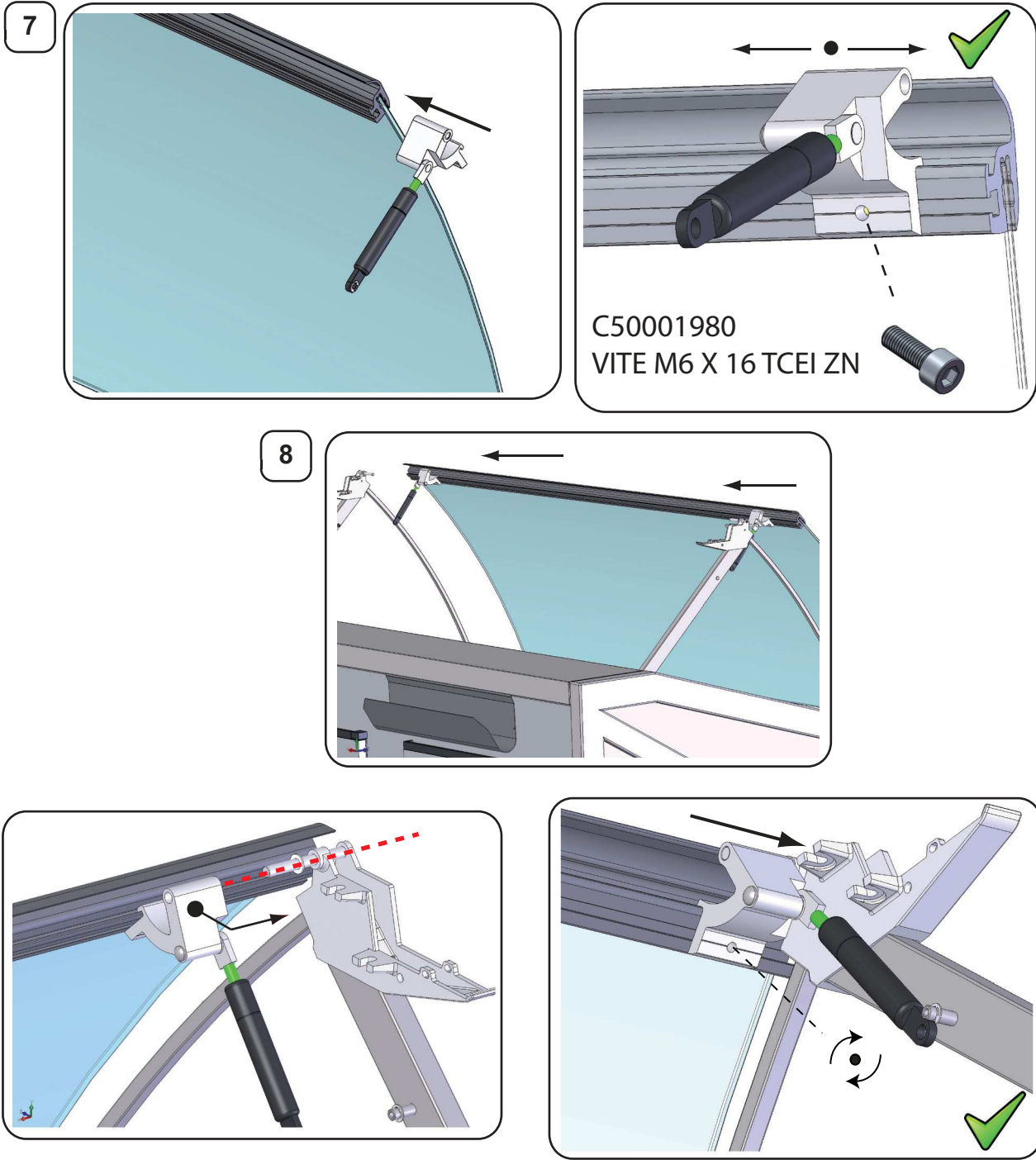
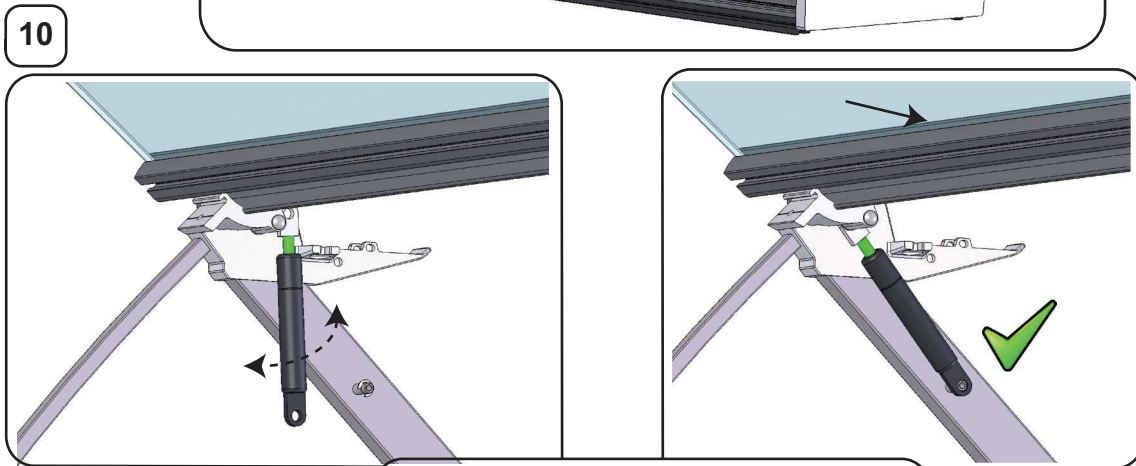
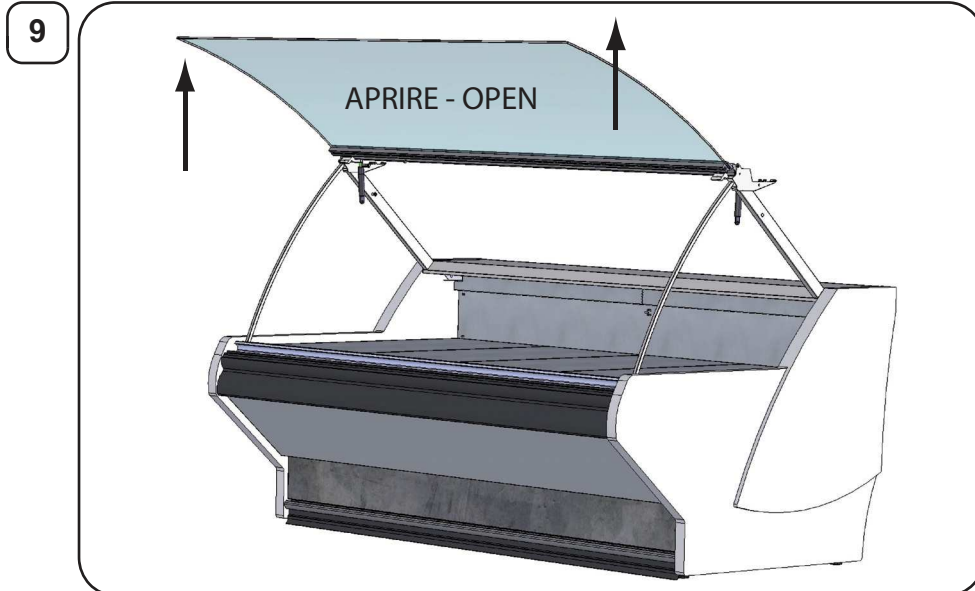


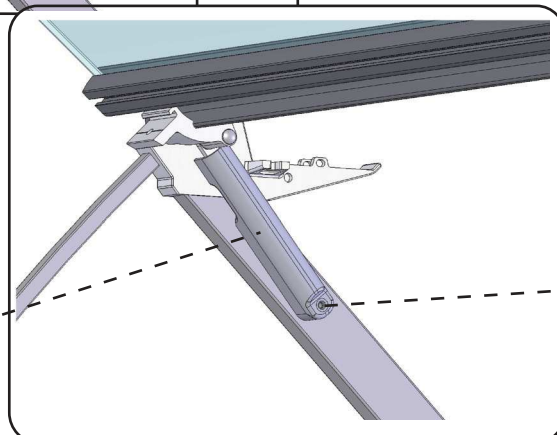
Fig. 24







- C70046570  
COPRIPSTONE SX PLUG-IN
- C70046580  
COPRIPSTONE DX PLUG-IN

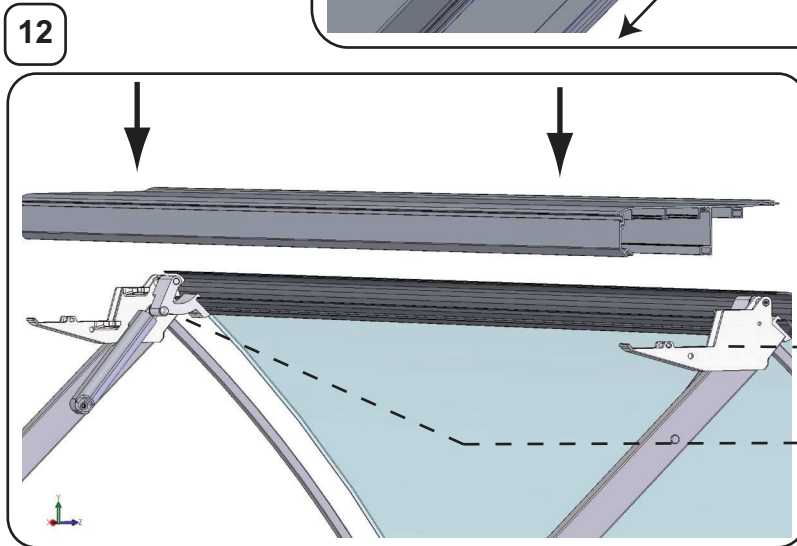
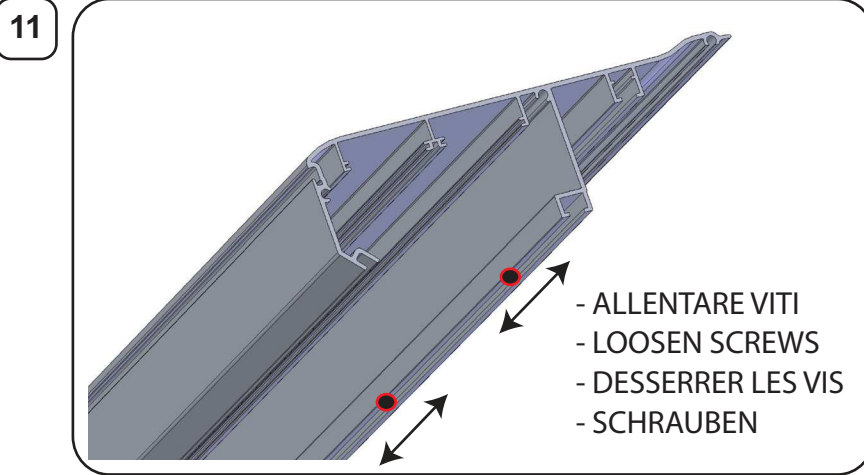


- C50006560  
VITE M4 X 8 TBEI

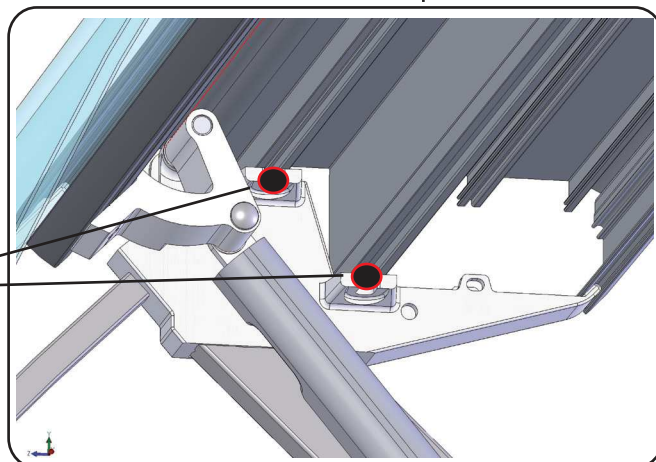


Fig. 26





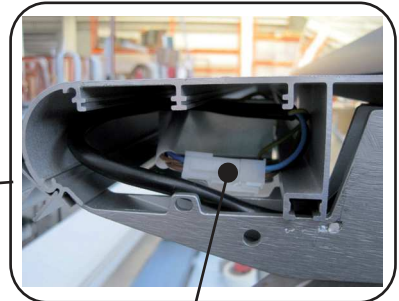
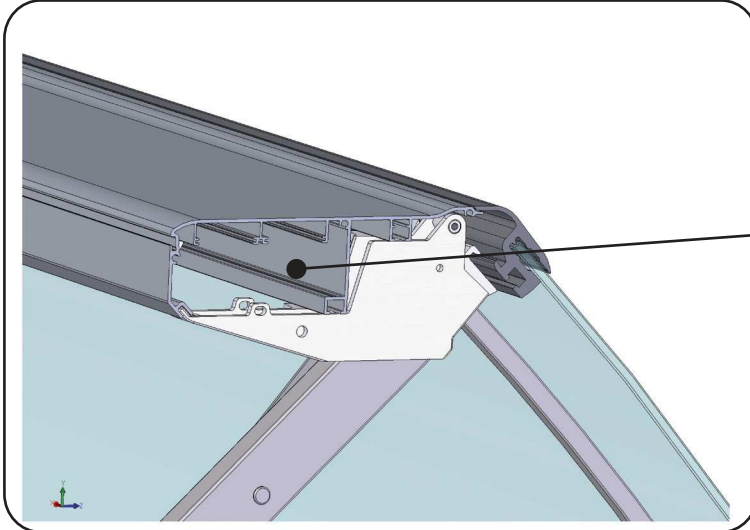
- FISSARE VITI
- FIXING SCREWS
- FIXATION DE VIS
- BEFESTIGUNGSSCHRAUBEN



13

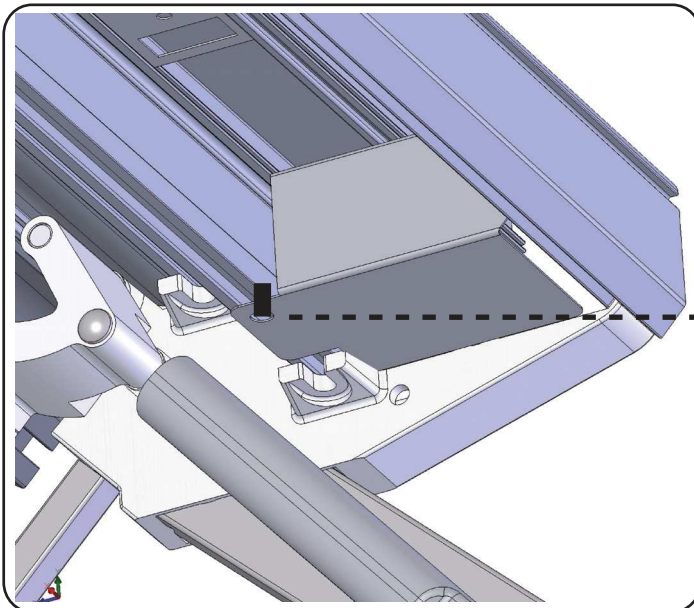
Fig. 27

14

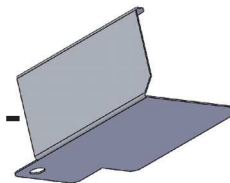


COLLEGARE  
CONNECT  
RELIER  
VERBINDEN

15



MASSA A TERRA



C70047670  
COP.CONNETTORE



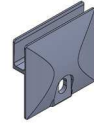
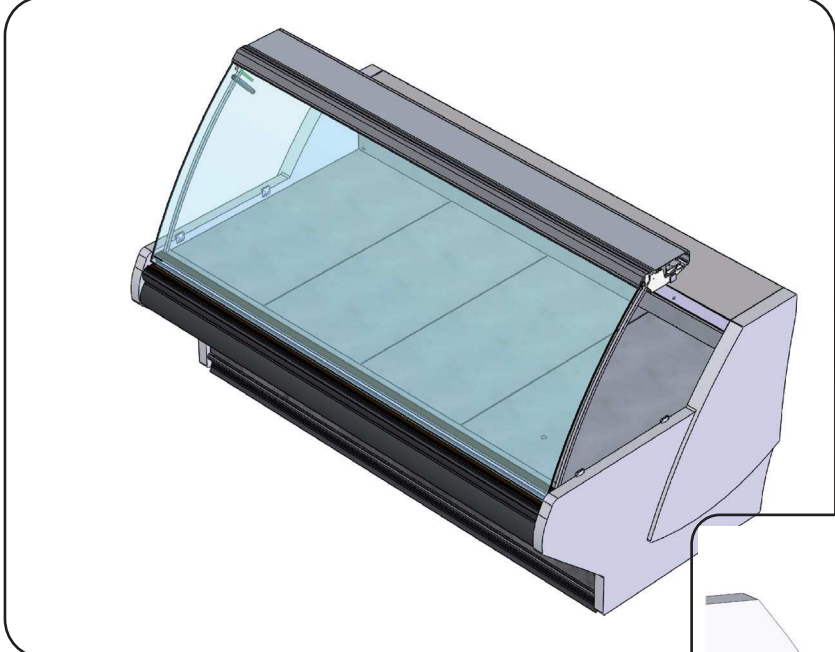
C50008060  
RONDELLA D.6,4X12



C50001800  
DADO CIECO M6

**Fig. 28**

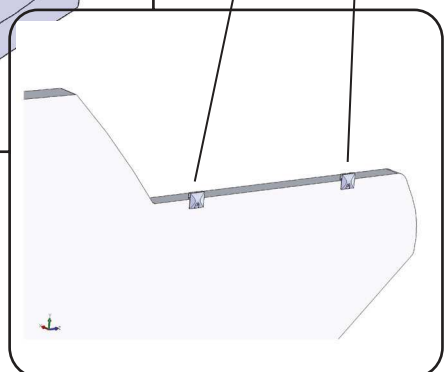
16



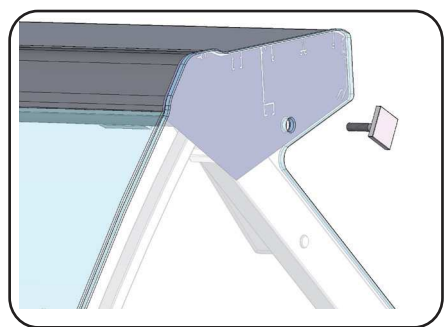
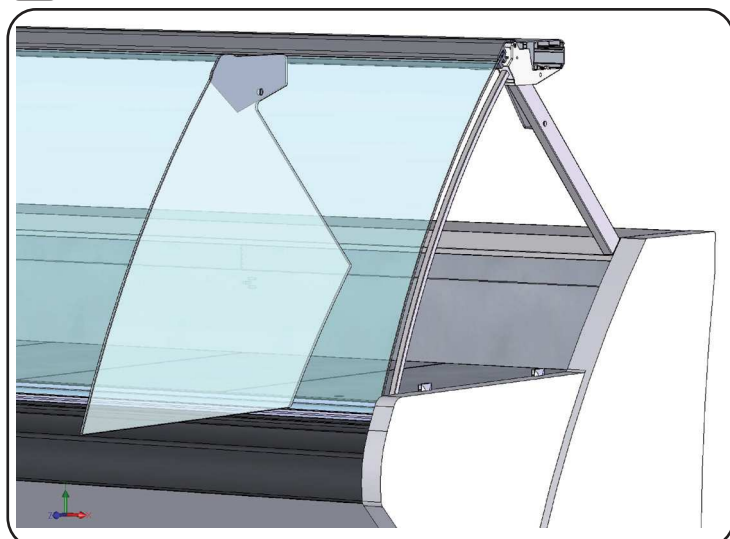
CP0004867  
SUPP.FIANCO VETRO SP.5



C50003550  
VITE AF 4,2X13 TC-IC IX



17



CP0001528  
BORCHIA 25X25 FILETTATA M6



**Fig. 29**

## 4.4 Disassembly and subsequent reassembly

**The Customer is responsible for the cabinet disassembly in order to move it and for its subsequent reassembly.**

For technical service, the Customer can apply to the Reseller.

## 4.5 Fixing

The cabinet described in this manual is provided with screw feet and therefore does not need to be fixed to the floor.

## 4.6 Installation

**Unless otherwise specified, the Customer is responsible for the operations mentioned below.**

### 4.6.1 Connection to a remote condensing unit

The connection to a remote condensing unit concerns only cabinets "without a refrigeration unit".



#### **Qualified**

Both the connection and the start-up shall be carried out by a Refrigerant Specialist. Refer to the cabinet layout for the position of the refrigerant fluid intake and outlet pipes.

### 4.6.2 Connection to the mains

Connect the cabinet to a mains power supply having an impedance lower than 0.228 ohm.

Line supply, frequency and voltage must correspond to those stated on the cabinet rating plate. When the compressor is started, the nominal voltage must be within  $\pm 10\%$ .

We recommend the use of a omnipolar isolation switch of adequate rating (C or D) upstream of the outlet.

Moreover, according to the law, both the system and the socket must be connected by a differential switch with 0.03 A release current.



#### **Warning!**

**The cabinet must be earthed.**

Before plugging in cabinets "with a refrigeration unit", check that the isolator is open, in 0, OFF or green position. Then plug the cabinet in and turn on the switch.

### 4.6.3 Connection to the drain line

The cabinet must be connected to a drain line if it is not provided with tanks collecting the condensate coming from inside the cabinet tank. In this case, connect the condensate drainage pipe to the drain line of the place where the cabinet has been installed.

## 4.7 Commissioning

### 4.7.1 Setting

Start-up settings are performed in the factory during the testing procedure by the Manufacturer.

As for set-up operation parameters, refer to the **List of parameters** in .

To modify the above mentioned parameters, refer to the enclosed "**Carel control unit instructions for use**".

**For the configuration and description of the keys please use the manual electronic control attached.**

### 4.8 Idle time and restarting

No special measures must be taken in case of prolonged idle times and subsequent restarting of the cabinet.

## 5. Instructions for use

**the Customer is responsible for the operations mentioned below.**

### 5.1 Correct use of the cabinet

**Note!**

**When using the cabinet we recommend to observe with the utmost scrupulousness the principles of the Hazard Analysis and Critical Control Point (Haccp)** concerning:



- personal hygiene of all the operators of food service;
- plant hygiene;
- food transport;
- interrupted cold chain;
- food preservation.

**Note!**

In particular:

products must be brought from the warehouses at a temperature close to their ideal storage temperature and immediately placed in the cabinet.



Filling the cabinet with products whose temperature is higher than that of the cabinet itself may make the cabinet operating conditions worse and even deteriorate the conservation of the already displayed goods.

To ensure the cabinet good operating conditions, displayed good must not obstruct the refrigerated air circulation.

**Note!**



Front glasses must be lifted to their maximum opening point and kept open only as long as it takes to store or remove food, or for cleaning purposes. Pistons act as a lifting back-up and prevent the glass from accidental falling.

If cabinets are provided with hatches, these must be opened only as long as it takes to store or remove food in order to avoid an anomalous rising of the cabinet working temperature.

**5.2 Uses to be avoided**



**Prohibition!**

Do not set temperatures lower than those recommended for the cabinet category. This would not bring any advantage and may block the evaporator.

Do not store goods over the maximum load line. This may cause ice formation on the evaporator, which may damage the thermal conditions of the correctly stored products.

Do not obstruct the air inlet grille located in the display surface front side.

**5.3 Working limits**

Refer to the enclosed "**Control unit instructions for use**".

**5.4 Cabinet control functions**

Here are the cabinet control functions reckoned among the Customer's common skills:

- *cabinet switching on;*
- *manual defrosting of the evaporator;*
- *setting temperature;*
- *periodical cleaning and maintenance;*
- *cabinet switching off.*

To carry out the listed control functions, refer to the enclosed "**Control unit instructions for use**".

**5.4.1 Manual defrosting**

In order to avoid ice formation on the evaporator and consequent reduction of cold air flow, the unit has an automatic system that will defrost the cabinet periodically, whose daily frequency has been preset by the Manufacturer during the testing procedure.

In case of an anomalous reduction of the refrigerated air flow, the manual defrosting of the cabinet must be carried out.

## 6. Maintenance instructions

### 6.1 General warnings

Maintenance operations described in this manual concern planned routine maintenance. **The Customer is responsible** for the routine maintenance of the equipment.

**Special maintenance** shall be carried out only by qualified personnel according to what stated in the "**Maintenance Manual**", which is not an integral part of this manual.

### 6.2 Periodical cleaning



**Warning!**

Before starting to clean the cabinet, unplug it from the mains.

**Cabinet cleaning:**

- **Clean every day** the areas around the display surface with water and a neutral detergent, then dry the parts with a soft cloth.
- **Clean weekly** both the product display surface and the tray bottom.



**Prohibition!**

**It is strictly forbidden to clean the cabinet with acid or ammonia-based compounds.**



**Warning!**

When cleaning the cabinet tray, after having removed the display shelves, be careful not to injure yourself on the evaporator fins as they may be sharp due to their reduced thickness.

**Condensing unit cleaning:**

- Drain **every day** the water collected in the special tray.
- Clean the unit at least **once a month** by using a vacuum cleaner and a hard bristle brush. A dirty condensing unit reduces motor performance and increases electricity consumption.



It is advisable to wear protective gloves when cleaning both the cabinet and the condensing unit.

## 6.3 Periodical maintenance

### 6.3.1 Check of the glass lifting system



**Qualified**

Check **at least once a year** that the glass lifting system works perfectly.

## 6.4 Special maintenance

The maintenance of the refrigeration system components pertains to special maintenance operations. Refer to "**Maintenance Manual**".

## 6.5 Troubleshooting



**Qualified**

Cabinet restoring shall be performed by a refrigerant specialist.

Refer to the enclosed "**Control unit instructions for use**".

The unit allows to control operation signals concerning the good working order of the cabinet, alarm signals with relative description and restoring modality.

## 7. Instructions for demolition and disposal

Make sure that all parts of the cabinet are disposed of in compliance with the laws in force in the User's country.

Pay particular attention to the following list of materials used to produce the cabinet and entrust their recovery and/or disposal to specialized and authorized companies:

- *thermal insulation;*
- *refrigerant fluid;*
- *electric and electronic components.*



**Warning!**

In particular, the refrigerant fluid disposal is very dangerous and shall be carried out through incineration by the refrigerant fluid producer.





**Prohibition!**

The refrigerant fluid is not easily biodegradable.

It must not be discharged in ground waters, rivers, sewages or on the ground.

---

## **8. Attachments**

---

### **8.1 Reference to manuals of other suppliers**

---

**Instructions of control unit: as attached.**

**Wiring diagram: attached.**

### **8.2 Declaration of conformity: as attached**

---





CRIOCABIN S.p.A.  
35033 Praglia di Teolo (PD) - Italy  
Z.I. Selve - Via S. Benedetto, 40/A  
Tel. +39 049 9909100  
Fax +39 049 9909200  
C.F. 01147330284 - P.I. IT 01147330284  
[www.criocabin.com](http://www.criocabin.com) - [sales@criocabin.com](mailto:sales@criocabin.com)

# ERGO



**CRIOCABIN**  
TASTE PRESERVATION