

TWICE

TWO-FOLD ISLAND



FEATURES INCLUDE:

Plug-in R134a refrigerant
B+1: 3M1 Temperature class
B+2: 3M2 Temperature class
3000°k LED lighting
Squared stainless steel bumper rail 20x20 mm available on demand
Front panels RAL 9010
Top canopy RAL 9005

Display deck/side panels: RAL 9006 (with stainless steel display deck). Other RAL colours or laminate available on demand.
Available with one or two shelves
Suitable for prepacked food display
Ideal for grab'n'go

TWICE

TWO-FOLD ISLAND

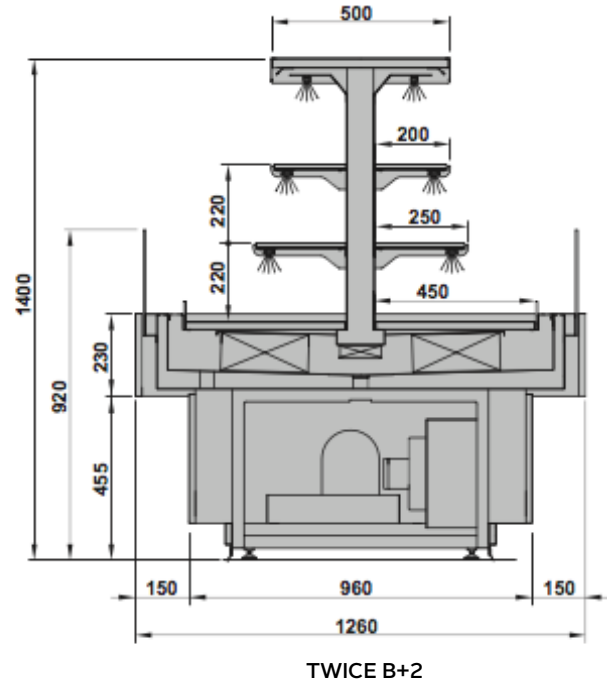
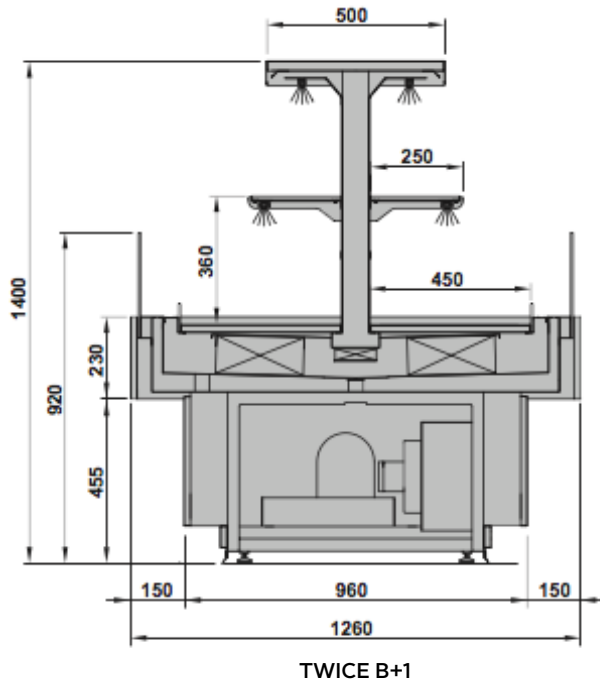

TWICE	1250	1875	2500
Operating temp. (°C)	+2/+4		
Refrigeration	Ventilated/R134a		
Defrost	Automatic		
Power supply	230V/1Ph/10 Amp plug	230V/1Ph/15 Amp plug	
Operating current (Amp)	7	12	13
Nominal power (W)	1600	2800	3000
Energy consumption (kWh/24h)	27	43	46
Number of shelves, B+1 model	1 each fold	1 each fold	1 each fold
Display surface B+1 model (m ²)	1.97	2.62	3.5
Number of shelves, B+2 model	2 each fold	2 each fold	2 each fold
Display surface B+2 model (m ²)	2.22	3	4
Length inc. bumpers (mm)	1370	1995	2620
Height inc. castors (mm)	1400	1400	1400
Depth incl. bumpers (mm)	1300	1300	1300
Weight w/o packaging (kg)	290	410	470

* Climate class 3 (25 °C, 60% hr)