

Angled Glass Top 352L Chest Freezer

| Chest Freezers

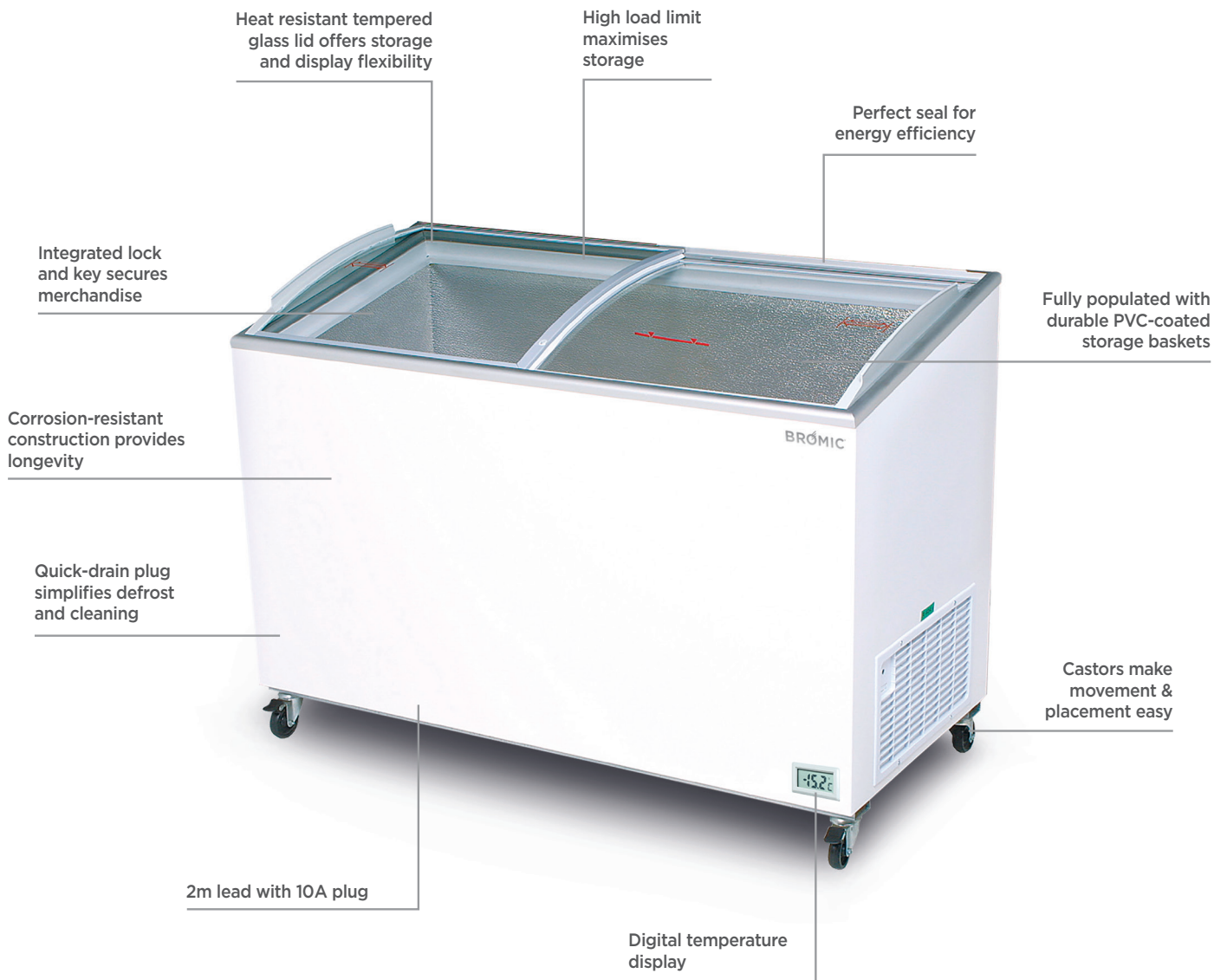

Angled Glass Top 352L Chest Freezer

| Chest Freezers

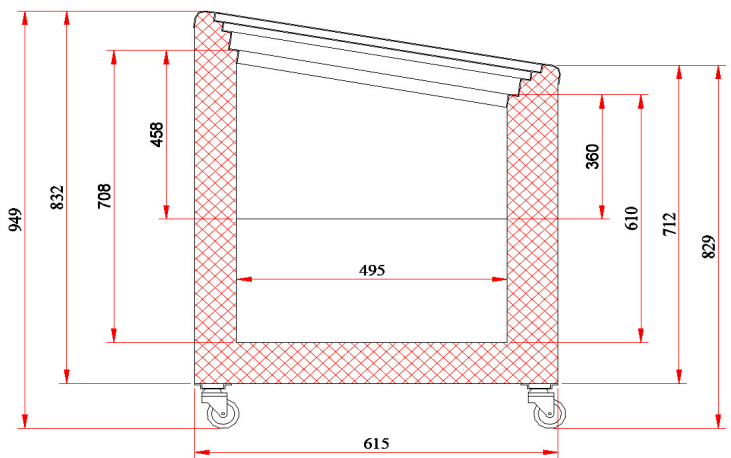
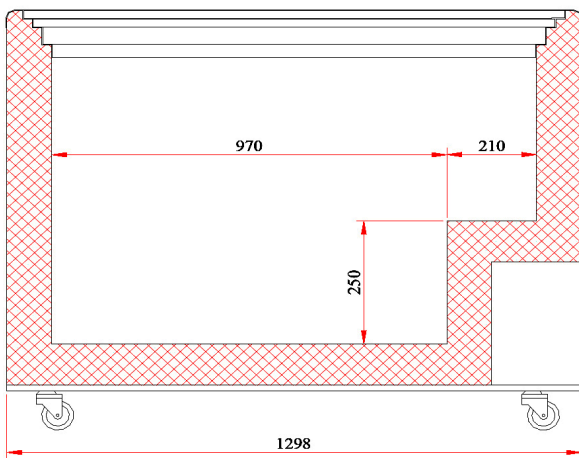

SPECIFICATIONS **DIMENSIONS**

Part Number	3735303-NR	Internal Light	No	External (mm)
Capacity	352L	No. of Lids	2	
Temperature Range	-22 to -12°C	Lid Type	Slide	
Max. Ambient Temp.	35°C	Lid Shape	Curved	Depth 615
Energy Consumption	2.645 kWh/24h	Lid Lock	Yes	Height 949
GEMS Star Rating	7 stars	Safety Glass Lid	Yes	Internal (mm)
Climate Class	4 L1	Lockable Front Castors	Yes	
Current	1.11A	No. of Baskets	5	
Gross Weight	81kg	Temp. Controller	Analogue controller, digital display	Width 1180
Packaged Dimensions	1330 x 680 x 980 mm	Colour	White	Depth 495
Air-Circulation	Static	Warranty	2 Years, Parts & Labour	Height 708
Refrigerant	R290		Bromic Extra Care	
Charge	110g			
Plug Supplied	Yes, 1 x 10A			
Plug Location	2m long, bottom right rear			