

# **BROMIC**<sup>®</sup> REFRIGERATION

***USE AND MAINTENANCE***

**IRENE**

The Cool Company Limited is happy to count you among its customers and confides that the quality of this product completely satisfies your expectations. This machine has been engineered in order to give the maximum performances with the best conditions of reliability and economy. Several strict tests were carried out during the productive phases in order to ensure all the above characteristics. It is easy to use and its regular maintenance operations do not require special procedure or the reparings of specialized personnel. Following the instructions given herein you will certainly obtain from this equipment excellent performance for a long time. Once again thank you for choosing The Cool Company equipment.

## INFORMATIONS ABOUT USE

### **SAFETY WARNINGS FOR THE APPLIANCES USING R290 COOLING FLUID (PROPANE)**

Propane is a natural gas that doesn't affect the environment but is inflammable. It is therefore indispensable to check that the cooling circuit tubing is not damaged before connecting the equipment to the mains. For every 8gr. of cooling fluid, the installation location must have a minimum volume of 1 cubic metre. The amount of cooling fluid in the appliance is indicated on the technical data plate on the back. Leakage of cooling fluid: avoid naked flames or over sources of ignition at the seat of the leakage. Be careful not to damage the cooling fluid circuit during positioning, installation or cleaning. Avoid flames or sparks inside the equipment.

#### **Warning!**

Do not damage the cooling fluid circuit

#### **Warning!**

Do not damage internal or external walls of the machine: the cooling fluid circuit may damage. In case of damaged walls do not start the machine and refer to a service centre.

#### **Warning!**

In case of damaged cooling fluid circuit, do not start the machine and refer to a service centre.

### **INSTALLATION**

Remove the packaging completely; clean the cabinet using warm water with a 5% concentration of neutral soap. Be sure to use a soft cloth for drying. Note that only specific product can be used for the glass, e.g. some types may leave behind limestone residues.

Cabinet must be installed on a perfectly even surface, far away from any heat source (radiators, stoves, etc) including sun rays.

Good running of the cabinet can be compromised in cases where the airflow is disturbed (wind, ventilators, air conditioning outlets, etc).

Smooth running of the cabinet is assisted when sufficient air is permitted to flow through the bottom of the unit; it is very important that the grills at the base are kept uncovered. Do not expose the cabinet to rain.

**Install and position the unit in such a way so as to allow easy access to the power socket.**

**Never use electrical equipment in the refrigerated compartment**

**Never place containers of liquid on or immediately above the ticket counter; should the content spill out, it would damage the counter.**

**THE REFRIGERATOR IS NOT SUITABLE FOR WORKING IN DANGEROUS ENVIRONMENT WITH RISK OF FIRE, EXPLOSIONS OR RADIATIONS.**

Operation is regular with ambient temperature indicated on **technical data plate**.

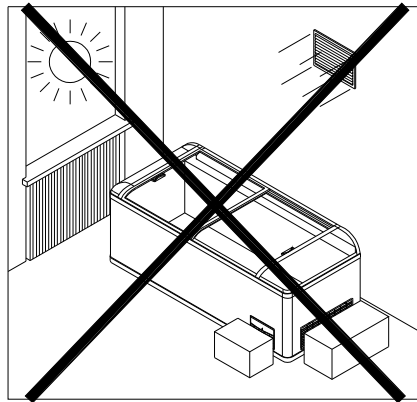
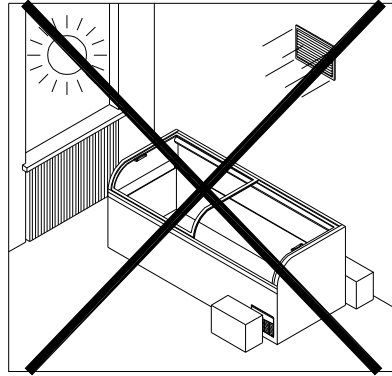

## GROUP INSTALLATION

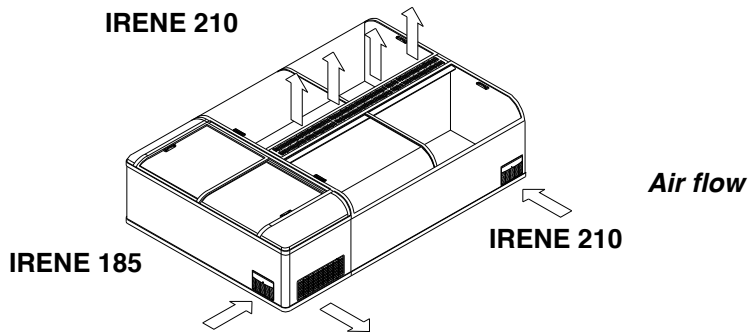
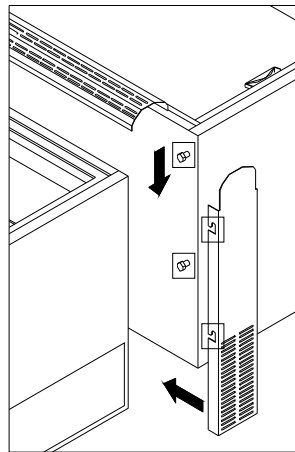
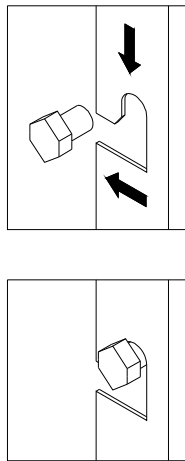
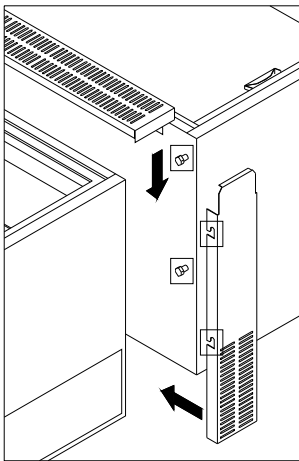
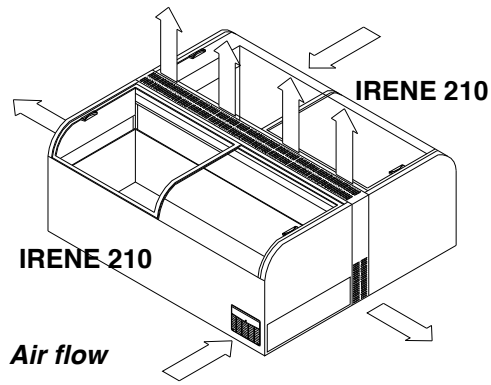
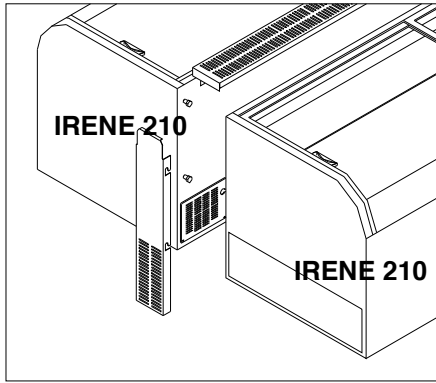

## PUTTING INTO OPERATION

Check that the voltage on the identification plate is the same as that of the network.

**THE ELECTRICAL SUPPLY LINE TO WHICH THE REFRIGERATOR WILL HAVE TO BE CONNECTED IS TO BE PROTECTED BY A VERY SENSITIVE DIFFERENTIAL SWITCH (Rc=16A,Dc=30mA); IT IS ALSO TO BE LINKED TO THE GENERAL EARTHING PLANT.** The manufacturer disclaims all responsibility for any damage to people or things due to incorrect observance of this rule. **Earthing is necessary and compulsory by law. Absolutely never use reduction units, patch cords, adapters or multiple socket outlets to connect the counter. DIRECTLY connect the equipment to the mains.** After plugging, wait till the appliance reaches the right temperature before filling it; don't place the product over the max. load level.

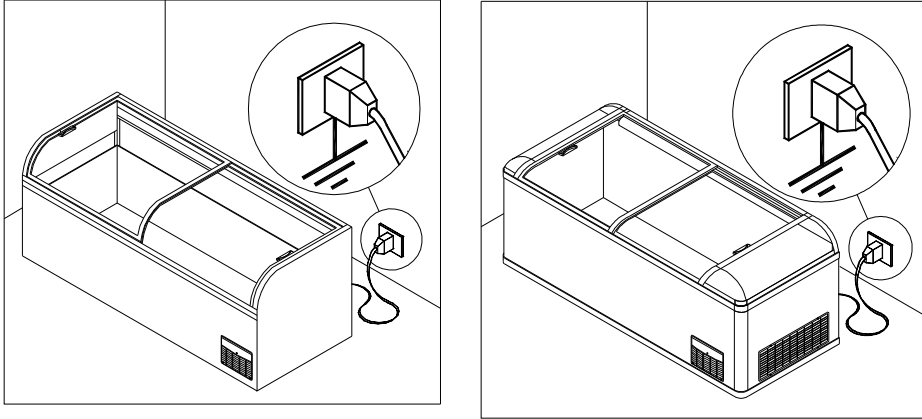

### WARNING!

The equipment must not be used by persons (including children) whose physical, sensorial, or mental capacities are reduced, or who lack experience and know-how, unless they have been provided, by means of a person responsible for their safety, with suitable monitoring or instructions about the use of the equipment. Children must be monitored to ensure they do not play with the equipment.

### SEASONAL USE

When the unit is not used for a long time, please take note of the following procedures:

- unplug the unit;
- clean and dry the tank well;
- leave the tank open to avoid possible formation of bad smells;
- cover the unit with a curtain, place it in a dry room, and sheltered from the atmospheric agents.

### PERIODICAL MAINTENANCE

**Any further adjustments on the refrigerator necessarily require the electric plug to be removed.** Check periodically the supply cable in order to detect any damage. If the power supply cable is damaged, don't use the equipment and don't try to repair it: to prevent any risk, it must be replaced by the manufacturer, by a member of the after-sales service staff, or anyway by a person having similar qualifications. In any case, none of the protective elements (the grill, the carter) must be removed by non qualified staff. Absolutely avoid using the refrigerator without such protection. **The replacement of neon tubes must be carried out only by an Authorized Service Center. The lamps have to be replaced by identical lamps only.**

# Instruction manual

For a good preservation of the cabinet's body a **periodical cleaning is necessary**.

**EXTERNAL BODY:** When necessary, the external body should be cleaned with a cloth and a **neutral soap and water solution**.

**STAINLESS STEEL SURFACES:** wash with warm water and mild detergent, rinse well and dry with soft cloth. **Avoid scouring pads etc. which will spoil the finish of the stainless steel.**

**SURFACES IN PLASTIC MATERIAL:** wash with warm water and mild detergent, rinse well and dry with soft cloth; **under no circumstances should alcohol, methylated spirits or solvents be used.**

**GLASS SURFACES:** **only use products specifically designed for glass cleaning;** it is not advisable to use ordinary water which can leave a film of calcium on the surface of the glass.

## DEFLECTOR GLASS

Place the deflector glass with writing 'TEMPERED' on left side.

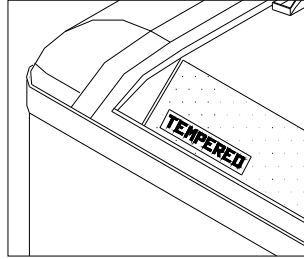
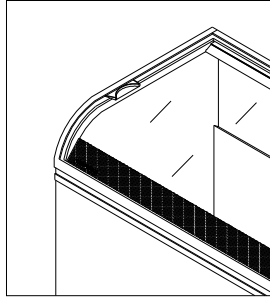

## TANK CLEANING

For a periodical tank cleaning, proceed as follows:

- 1) Place the product in special refrigerated containers, kept at the same temperature.
- 2) Unplug the unit.
- 3) Before cleaning the tank the inside temperature must be equal to the ambient temperature.
- 4) Carefully wash the tank with water and neutral soap; rinse and dry well.
- 5) Plug in again and wait till the appliance reaches the right temperature before filling it again.

**Do not use jet of water to clean the cabinet: electrical wiring could be damaged.**

**Never use mechanical devices or any other means to accelerate the defrosting process, other than those recommended by the manufacturer.**

## INFORMATIONS ABOUT SERVICE

### DRAWBACKS AND REMEDIES

The fault of working that are normally found in refrigerating appliances are mostly due to unimportant reasons or to a faulty electrical installation.

These cases can be easily eliminated on field.

#### The refrigerator isn't working:

- check that voltage reaches the socket;
- check that the unit is well plugged in;

#### The inside temperature isn't low enough:

- check that the unit isn't near a source of heat or a draught;
- check if there is too much frost on the walls of the tank;
- check if the temperature adjuster is set on a wrong position;
- check the perfect closing of the lids;

#### The unit is noisy:

- check that all screws and bolts are well tightened;
- check if the unit is well levelled;
- check that any tube or fan blade is in contact with other parts of the unit.

## ELECTRIC CONNECTIONS

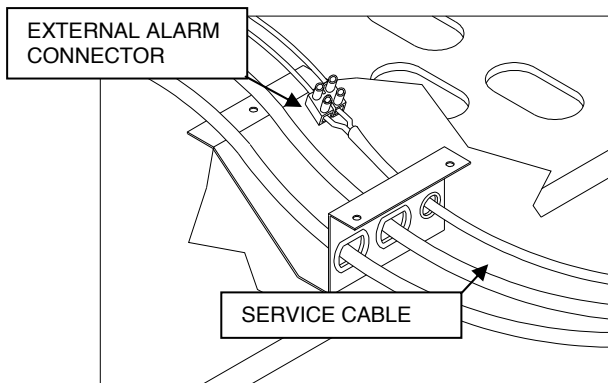
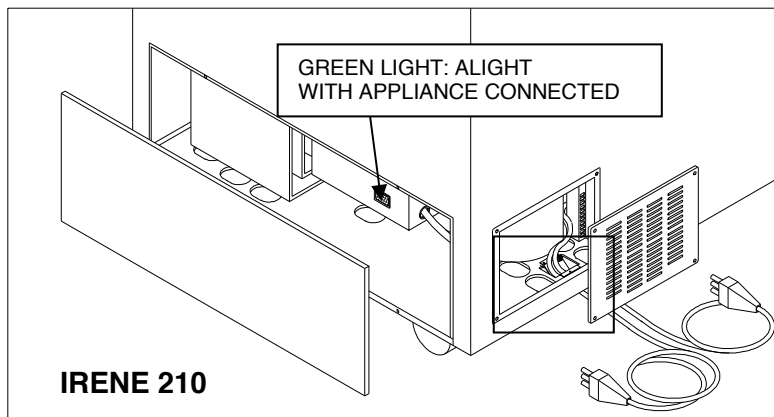

The appliance is supplied with both a power cord and a light connection cord. There is also an alarm system that indicates any abnormal temperature. This alarm system consists of a red light signal (see controls) and a buzzer. If you want to extend the alarm signal outside of the appliance need to connect with a cable service to the connector placed on the support as shown.

**Warning!**  
**Maximum output current: 1 A**

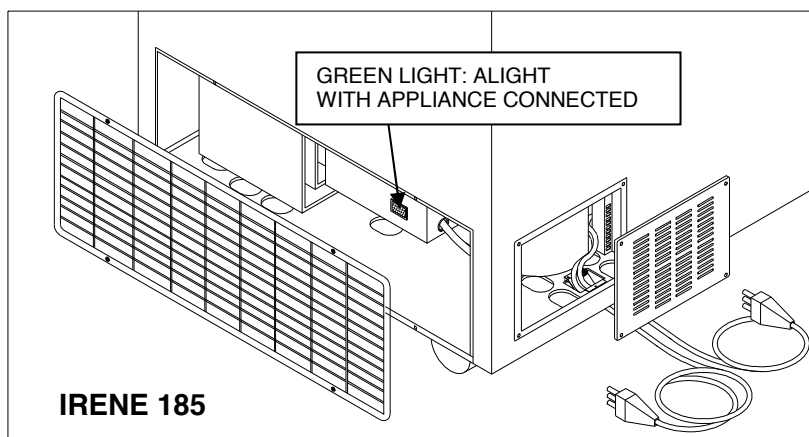

## TEMPERATURE SETTING AND CONTROLS (Digital Controller)

Each refrigerating appliance is provided with an electronic thermostat for automatic maintenance of the appropriate pre-established temperature inside the tank. This temperature adjuster is gauged by the factory and should not be touched by the user. Pushing button (A) you can see on display the Setpoint. You can increment or decrement Setpoint by pushing button (C) or (B). **Defrosting is automatic:** Push button (C) (for 5") to set an automatic defrosting. During defrosting time is alight led (F).

### CONTROLS

- 1) Electronic control
- 2) Alarm led light when it is alight during normal running it indicates a trouble in the refrigerating equipment.

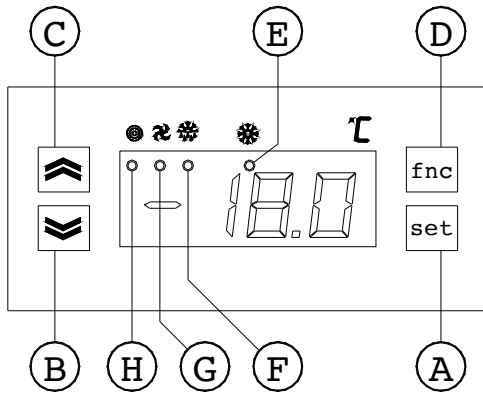
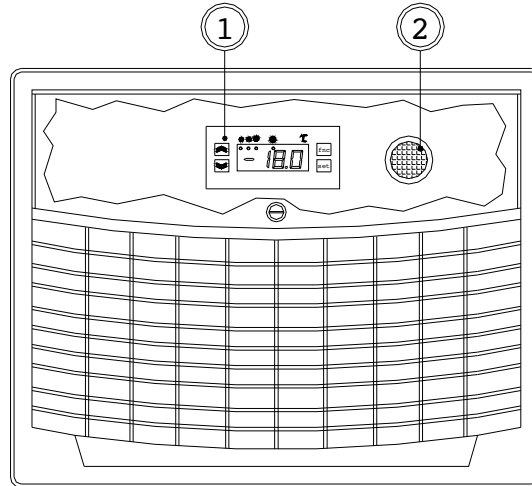

### ELECTRONIC CONTROL

- A) Button to show set point
- B) Button to decrease set point
- C) Button to increase set point
- D) 'ESCAPE' button
- E) Compressor led light : alight when compressor is running
- F) Defrosting led: alight during defrosting time
- G) Evaporator fan led light: alight when motor fan is running
- H) Alarm led light

## TEMPERATURE SETTING AND CONTROLS (Analog Controller)

Each refrigerating appliance is provided with a thermostat for automatic maintenance of the appropriate pre-established temperature inside the tank. This temperature adjuster is gauged by the factory and should not be touched by the user. Only if the average internal temperature is too cold or not cold enough should the knob (1) be turned. The numbers on the regulation plate are not related to temperature values but only to knob reference position: a higher number corresponds to a lower temperature. **Defrosting is automatic.**

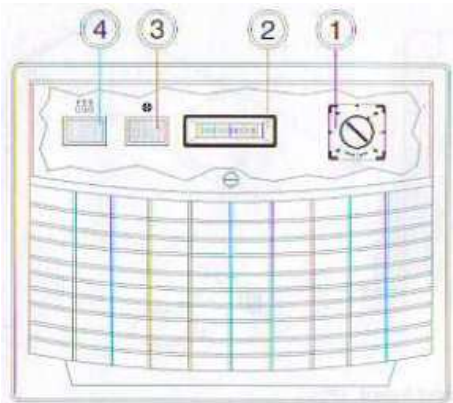

### **SUPERMARKET VERSION** **(Climate Class 3)**

#### **CONTROLS**

- 1) Thermostat
- 2) Thermometer
- 3) Red warning led light: when it is alight during normal running it indicates a trouble in the refrigerating equipment.
- 4) Led light alight during defrosting time

### **RETAIL VERSION** **(Climate Class 4)**

#### **CONTROLS**

- 1) Thermostat
- 2) Thermometer
- 3) Main switch
- 4) Led light alight during defrosting time
- 5) Light switch

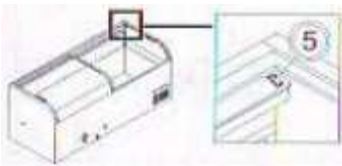
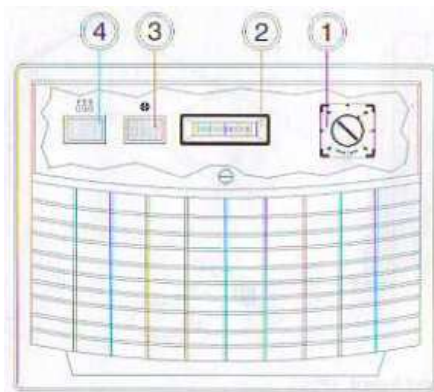

### **IMPORTANT INFORMATION FOR CORRECT DISPOSAL OF THE PRODUCT IN ACCORDANCE WITH EC DIRECTIVE 2002/96/EC**

At the end of its working life, the product must not be disposed of as urban waste. It must be taken to a special local authority differentiated waste collection centre or to a dealer providing this service. Disposing of a household appliance separately avoids possible negative consequences for the environment and health deriving from inappropriate disposal and enables the constituent materials to be recovered to obtain significant savings in energy and resources. As a reminder of the need to dispose of household appliances separately, the product is marked with a crossed-out wheeled dustbin.



**IRENE 210**

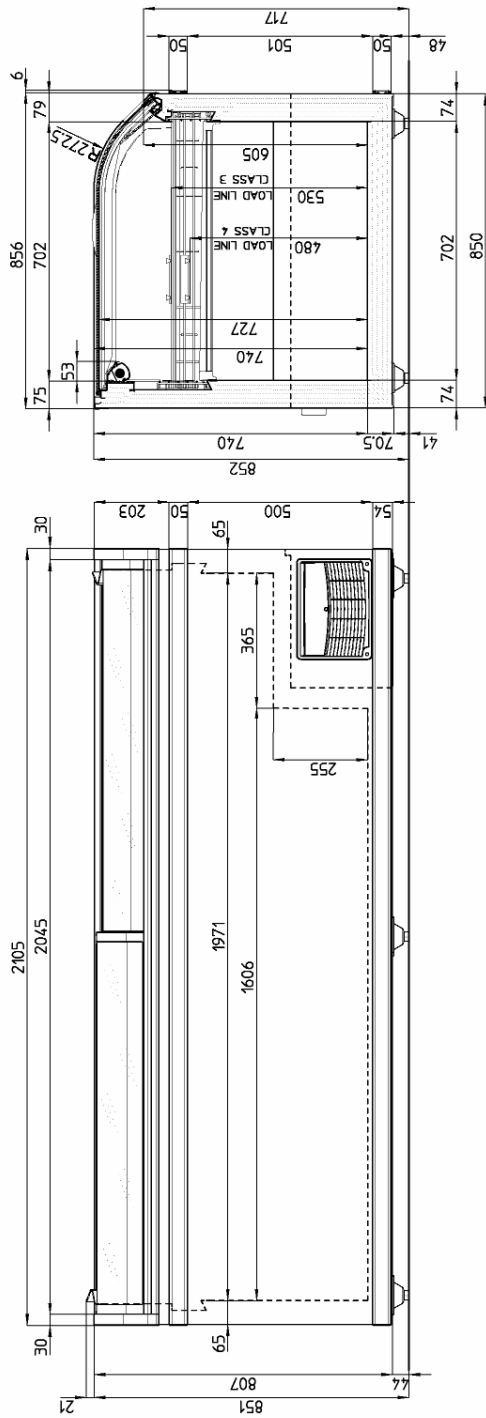

Net Vol.		Gross Vol.
In Class 3	In Class 4	
668 dm <sup>3</sup>	600 dm <sup>3</sup>	950 dm <sup>3</sup>

**IRENE 250**

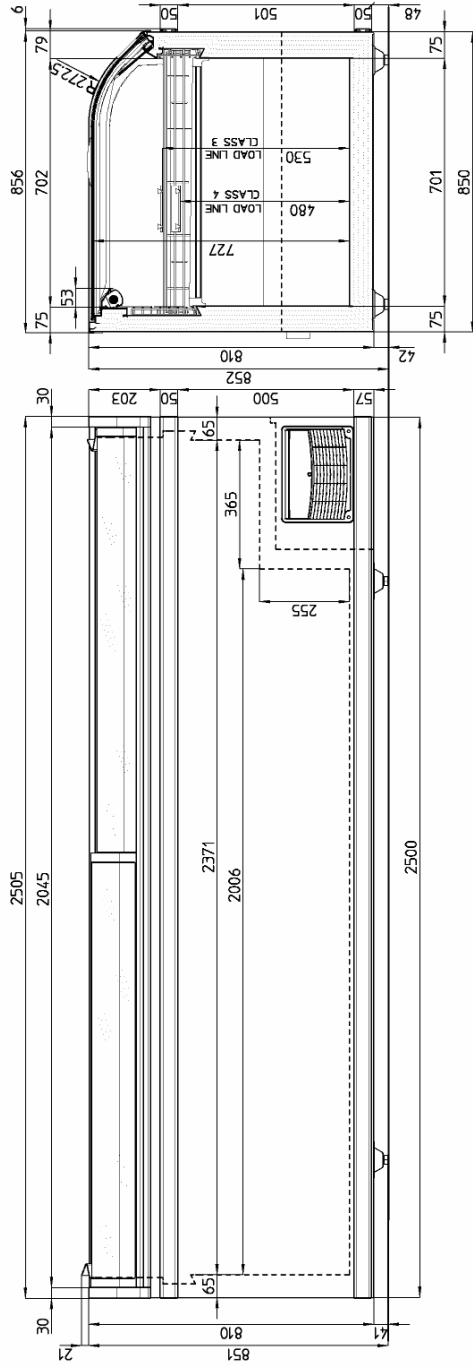

Gross Vol.	Net Vol.	
	In Class 3	In Class 4
1155 dm <sup>3</sup>	815 dm <sup>3</sup>	732 dm <sup>3</sup>

Irene

**IRENE 185**

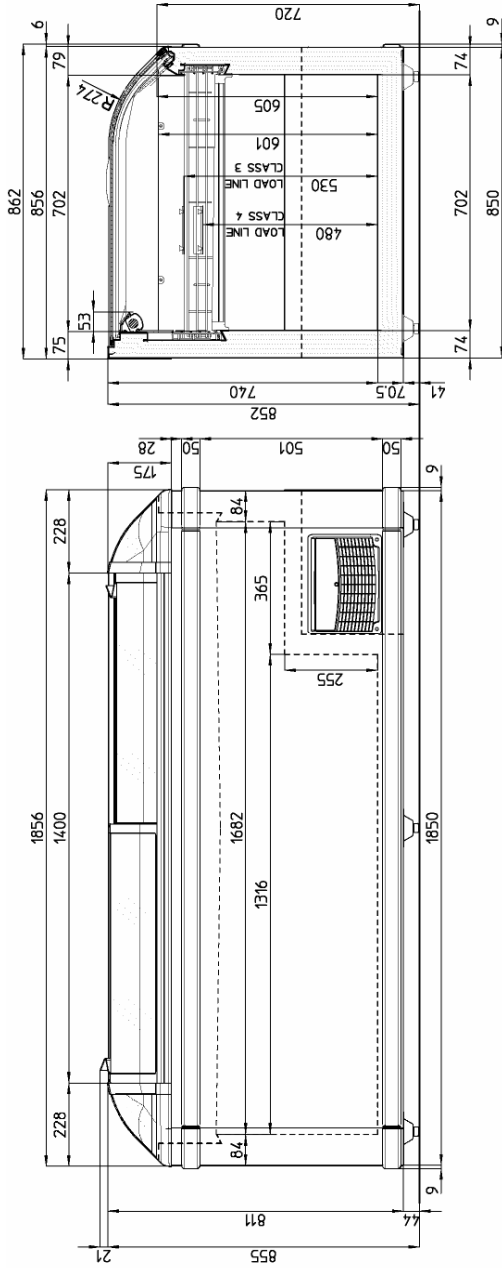

Gross Vol.	Net Vol.	
	In Class 3	In Class 4
<b>800 dm<sup>3</sup></b>	<b>560 dm<sup>3</sup></b>	<b>501 dm<sup>3</sup></b>

**This refrigeration appliance for commercial use  
is in conformity with the following standards or other normative document:**

<b>EN 55014-1</b> .....	<b>Ed.2006</b>
<b>EN 55014-2</b> .....	<b>Ed.1997</b>
<b>EN 61000-3-2</b> .....	<b>Ed.2006</b>
<b>EN 61000-3-3</b> .....	<b>Ed.1995</b>
<b>EN 60335-1</b> .....	<b>Ed.2002</b>
<b>EN 60335-2-89</b> .....	<b>Ed.2002</b>

Following the provisions of the Directives:

**EC 2006/95, EC 2004/108**

**Manufacturer: IARP srl.**

**Distributor: The Cool Company Limited  
193/53 14th Fl., Lake Rajada Office Complex  
Ratchadapisek Road, Klongteoy, Bangkok  
10110 Thailand  
Tel. +66 (0) 2661 8228  
Fax. +66 (0) 2661 8822**