

## CF0700FTSS | Flat Top Stainless Steel 675L Chest Freezer

Chest Freezers

**CF0700FTSS**

**FLAT TOP  
STAINLESS STEEL  
675L CHEST  
FREEZER**

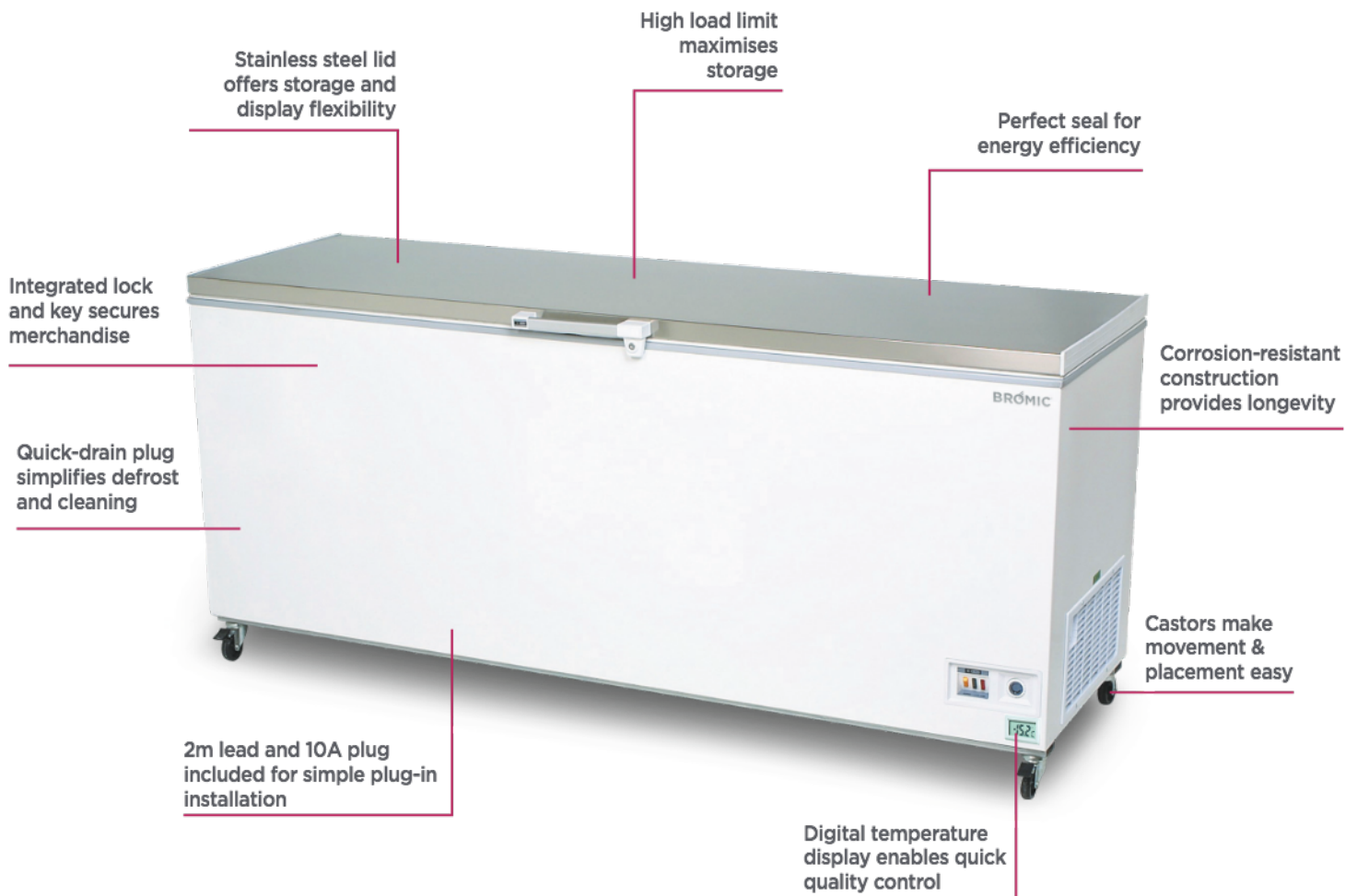

## CF0700FTSS | Flat Top Stainless Steel 675L Chest Freezer

### Chest Freezers

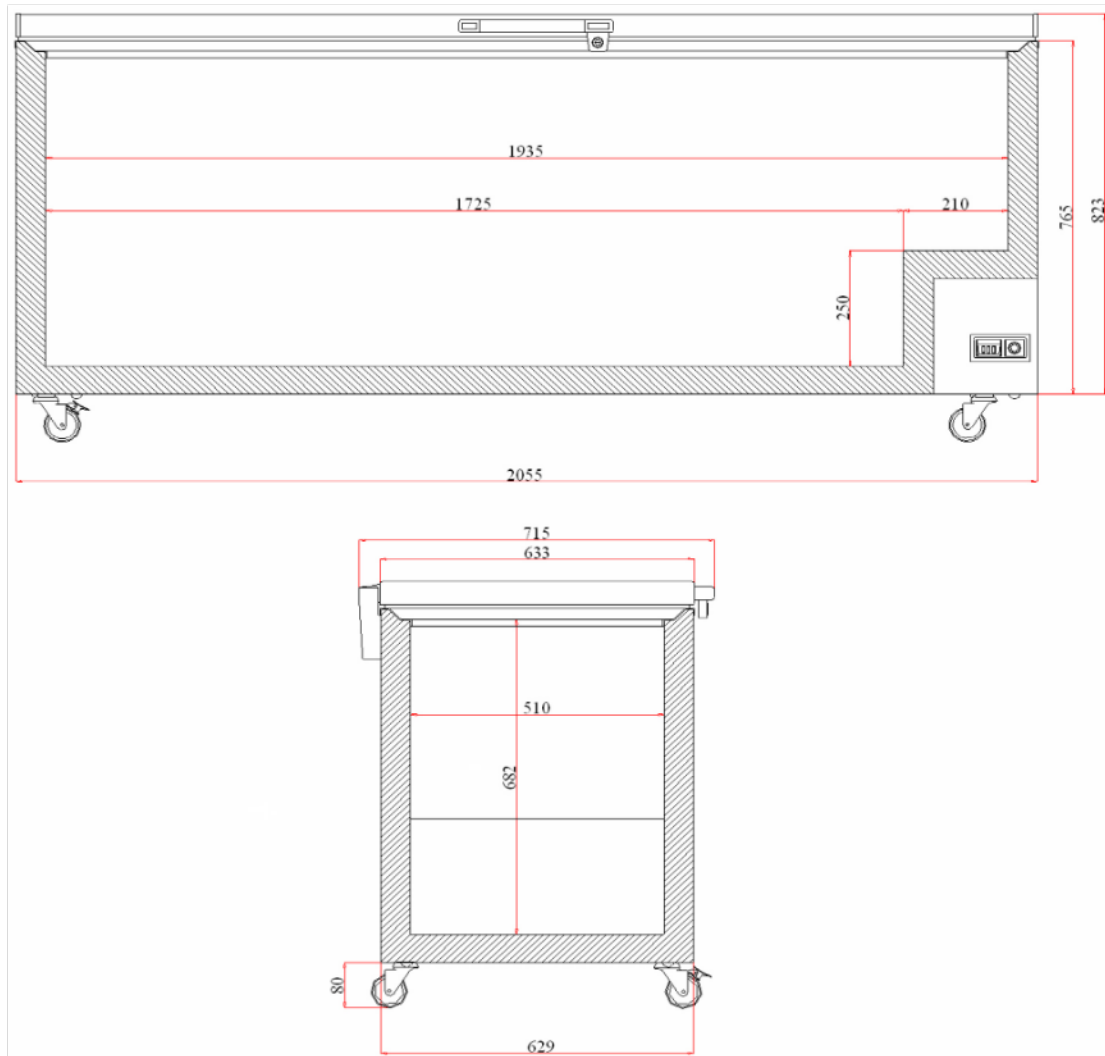

### SPECIFICATIONS

Part Number	3735306	Internal Light	Yes
Capacity	675L	No. of Lids	1
Temperature range	-25 to -15°C	Lid Type	Hinged - Stainless Steel
Max. Ambient Temp	35°C	Total Height with lid open	1618mm
Refrigeration Capacity	425W	Lid Shape	Flat
Energy Consumption	4.9kWh/24h	Lid Lock	Yes
Current	2.9A	Temp. Controller	Digital
Gross Weight	119kg	Castors	Yes
Packaged Dimensions	2145 x 750 x 1005 mm	No. Baskets Included	3
Air-Circulation	Static	Colour	White
Refrigerant	R404a	Warranty	2 Years, Parts & Labour
Plug Supplied	Yes, 1 x 10A	Warranty Service	Bromic Extra Care
Plug Location	2m long, bottom right rear		

### DIMENSIONS

	External (mm)	Internal (mm)
Width	2055	1935
Depth	715	510
Height	903	682

All information is correct at the time of publication. BROMIC PTY Ltd reserve the right to alter specifications without notice.