

# Cake Display Refrigerators

## Features:

- Digital temperature display and electronic controller
- Dynamic fan forced cooling system with auto defrosting
- Double layer glass for maximum insulation
- Dark grey stainless steel finish
- Shelf material: frosted glass

- Sliding door for easy access
- LED internal light
- Refrigerant: R290
- Frequency/voltage: 50Hz/220-240 V
- Ambient temperatures from +16°C to +30°C



## CDS309B

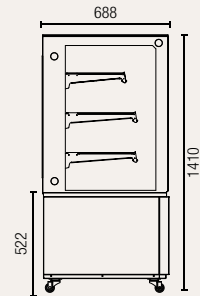
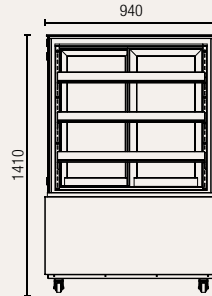

**Gross volume:** 390 L

**Exterior dimensions in mm:** 940w x 688d x 1410h

**Number of adjustable shelves:** 3

**Temperature set range:** 0°C to +12°C

**Gross/net weight:** 190/162 kg

**Energy consumption in 24h:** 4.42 kWh

## CDS312B

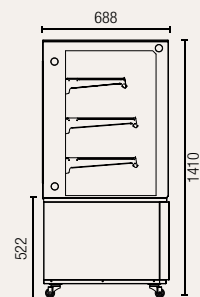
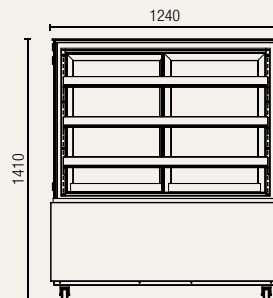

**Gross volume:** 530 L

**Exterior dimensions in mm:** 1240w x 688d x 1410h

**Number of adjustable shelves:** 3

**Temperature set range:** 0°C to +12°C

**Gross/net weight:** 229/195 kg

**Energy consumption in 24h:** 5.96 kWh

## CDS315B

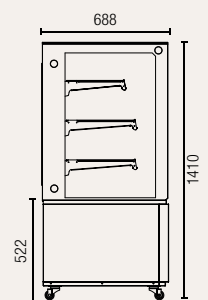
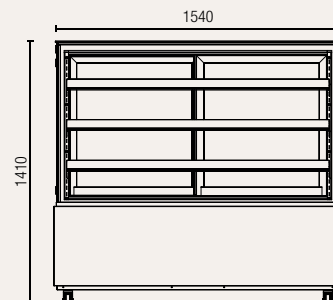

**Gross volume:** 670 L

**Exterior dimensions in mm:** 1540w x 688d x 1410h

**Number of adjustable shelves:** 3

**Temperature set range:** 0°C to +12°C

**Gross/net weight:** 252/229 kg

**Energy consumption in 24h:** 6.15 kWh